

Barletta
BOATS

OWNER'S MANUAL



RESERVE

Lusso

CORSA

Cabrio

Aria

FUEL SYSTEMS

Boats manufactured for use in California for model year 2018 and after meet the California EVAP Emissions regulation for spark-ignition marine watercraft. Boats meeting this requirement will have the following label affixed near the helm.

WARNING

Operating, servicing and maintaining a recreational marine vessel can expose you to chemicals including engine exhaust, carbon monoxide, phthalates and lead, which are known to the State of California to cause cancer and birth defects or other reproductive harm. To minimize exposure, avoid breathing exhaust, service your vessel in a well-ventilated area and wear gloves or wash your hands frequently when servicing this vessel. For more information go to: www.P65warnings.ca.gov/marine

The fuel system in boats marketed in states other than California complies with U.S. EPA-mandated evaporative emission standards at time of manufacture using certified components.

CALIFORNIA AIR RESOURCES BOARD (CARB)

Outboard, sterndrive and inboard powered boats sold in the state of California are equipped with special components and certified to meet stricter environmental standards and exhaust emissions. All boats sold in California since 2009 are required to meet Super-Ultra-Low (four-star) emissions.

EXHAUST EMISSIONS



Sterndrive and inboard marine engine powered boats meeting CARB's exhaust emission standards are required to display the four-star label on the outside of the hull above the waterline. Outboard and personal watercraft marine engines may also comply with these standards.

DANGER

Carbon monoxide (CO) can cause brain damage or death. Engine and generator exhaust contains odorless and colorless carbon monoxide gas. Carbon monoxide will be around the back of the boat when engines or generators are running. Signs of carbon monoxide poisoning include nausea, headache, dizziness, drowsiness and lack of consciousness. Get fresh air if anyone shows signs of carbon monoxide poisoning. See engine manufacturer's manual for information regarding carbon monoxide poisoning.

SEE YOUR LOCAL BARLETTA DEALER FOR THESE ACCESSORIES AND MORE

FLAG AND FLAG KITS

Available in Aria, Cabrio, Corsa, Lusso and Reserve Leggera models.



SAFETY RAILS

Available in Aria, Cabrio, Corsa and Lusso models.

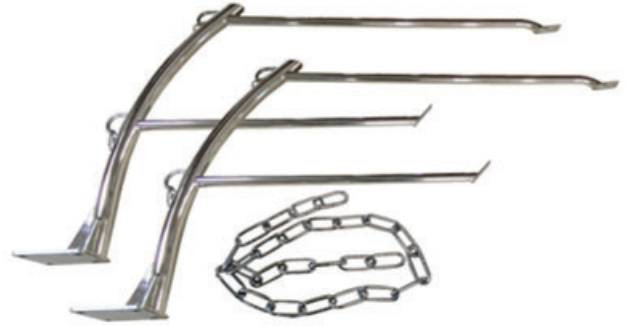

TABLE KIT

Available in Aria, Cabrio, Corsa, Lusso and Reserve Leggera models.



CHANGING ROOM KIT

Available in Aria, Cabrio, Corsa, Lusso and Reserve Leggera models.





SEE YOUR LOCAL BARLETTA DEALER FOR THESE ACCESSORIES AND MORE

BOW FILLER

Available in Cabrio, Corsa and Lusso models.



MESH SPEED TOP

In place of standard Bimini Canvas.

Available in Aria, Cabrio, Corsa and Lusso models.



WEIGHTED PILLOW

Available in Cabrio, Lusso and Reserve Leggera models.



FENDER HOLDERS

Available in Aria and Cabrio models. Standard on Corsa, Lusso and Reserve Leggera models.



OTTOMAN/COOLER

Available in Cabrio, Corsa, Lusso and Reserve Leggera models.



PORTABLE CUPHOLDERS

Available in Cabrio model.





CUSTOM-BARLETTA SWIM MAT RACKS

MAT NOT INCLUDED

Available in Aria, Cabrio, Corsa, Lusso and Reserve Leggera.



RGB LIGHT KIT

Available on Aria, Cabrio and Corsa models.



EXTERIOR LIGHT KIT

Available on Aria, Cabrio, Corsa and Lusso models.



SUB AND AMPLIFIER

Available on select models.



POWER JBL RALLY BAR

Available on Corsa Arch Boat model.



This Page Intentionally Left Blank

TABLE OF CONTENTS

See Your Local Barletta Dealer for These Accessories and More	i
Introduction	1-1
About This Manual.....	1-1
Important Items to Note About Your New Barletta.....	1-1
About Your New Boat.....	1-3
Boat Terminology.....	1-3
Strong Points.....	1-3
Hull Identification, Capacity and Safety Plates.....	1-4
Design Category.....	1-5
Disclaimer.....	1-5
References and Contact Information.....	1-5
Boat Information Form.....	1-7
Safety	2-1
Good Safety Practices.....	2-1
Safety and Training.....	2-2
Safety Labels.....	2-3
Safety Statements.....	2-3
Barletta Safety Tags.....	2-3
Safety Precautions.....	2-4
Required Boating Safety Equipment and Regulations.....	2-8
Fire Extinguisher.....	2-9
Engine Cut-Off Switch and Link.....	2-9
Life Jackets.....	2-9
Visual Distress Signaling (VDS) Devices.....	2-13
Audible Signaling Devices.....	2-14
Navigational Lights.....	2-15
Recommended Safety Equipment.....	2-16
Very High Frequency (VHF) Radio.....	2-17
Personal Location Beacon (PLB).....	2-17
Situational Awareness.....	2-17
Driving Defensively.....	2-18
Small Boats and Swimmers.....	2-18
Knowing the Boat.....	2-18
Special Needs Passengers.....	2-18
Cruising Limitations.....	2-19
Hazard Information.....	2-19
Water Sports.....	2-19
Platform Dragging.....	2-20
Water Sports Guidelines.....	2-20
Boating Regulations and Your Responsibilities	3-1
Boat Owner / Operator Responsibilities.....	3-1
Safety.....	3-1
Registration.....	3-1
Insurance.....	3-1
Reporting Accidents.....	3-2
Boating Under the Influence.....	3-2
Operator's License and Education.....	3-2
Operation By Minors.....	3-2
Emergency Assistance.....	3-2



TABLE OF CONTENTS

Negligent Operation	3-3
Restricted Areas	3-3
America’s Waterway Watch	3-3
Fishing	3-3
Wake	3-4
Noise	3-4
Speed	3-4
Protecting the Environment	3-4
Aquatic Invasive Species (AIS)	3-4
Paints	3-5
Cleaning Agents	3-5
Exhaust Emissions	3-5
Emergencies	4-1
First Aid / Medical Emergencies	4-1
Emergency Preparation Checklist	4-1
Using Distress Signals	4-1
Requesting Assistance (Non-Distress Call)	4-2
Fire and Explosion	4-2
Man Overboard (MOB)	4-3
Capsizing and Flooding	4-3
Running Aground	4-3
Dangerous Weather	4-4
Engine or Boat System Failure	4-4
Accidents, Collisions and Giving Assistance	4-4
Towing on the Water	4-4
Law of Salvage	4-5
Hurricane and Severe Weather Preparedness	4-5
Protecting the Boat from Theft	4-6
Operating in Hazardous Conditions	5-1
Severe Weather	5-1
Storm Conditions	5-1
Fog Conditions	5-1
Reduced Visibility	5-1
Cold Weather	5-1
Water Hazards	5-1
Aquatic Vegetation/Weeds	5-2
Dams and Spillways	5-2
Shallow Water Operation	5-2
Markers, Warnings and Advisories	5-2
Boat Flags	5-3
Harbor Flags and Indicators	5-3
Navigation Rules and Aids	6-1
Rules of the Road	6-1
Right-of-Way	6-1
Crossing	6-1
Meeting Head-On	6-2
Overtaking / Passing	6-2
Audible Signals	6-2
Aids to Navigation	6-2



Buoys	6-3
Daymarks / Dayboards	6-3
Lights and Lighted Structures	6-3
Markers	6-4
Navigational Lights and Night Operation	6-9
Helm and Controls	7-1
About this Section	7-1
Reserve and Reserve Leggera	7-1
Lusso and Lusso Twin Engine	7-3
Lusso Twin Engine	7-4
Mercury Joystick	7-4
Lusso Single Engine	7-5
Corsa	7-6
Cabrio	7-8
Aria	7-11
Shift and Throttle Controls	7-14
Neutral Start Safety Switch	7-14
Control Operation Guidelines	7-14
Single-Lever Controls - Single or Twin Engine	7-14
Easy Dock Thruster System	7-15
Trim / Tilt Switch	7-15
Trim / Tilt Gauge	7-15
Voltmeter	7-15
Hour Meter	7-15
Engine Cut-Off Switch and Link	7-16
Boat Features and Options	8-1
Electrical System	8-1
DC System	8-1
Fuel System	8-1
Steering System	8-2
Mechanical Steering	8-2
Hydraulic Steering	8-2
Power Assist Steering	8-2
Electric Power Assist Steering	8-2
Propellers	8-3
Propeller Selection and Replacement Guidelines	8-3
Gauges / Instruments	8-3
Multi-Gauges	8-3
Fuel Level Gauge	8-4
Accessory Ports	8-4
Helm and Control Switches	8-4
Battery Switch	8-4
Easy Dock Thruster System	8-5
Fuel Burning Appliances	8-5
General Operation of Fuel-Burning Appliances	8-6
Propane Gas Grill	8-6
Fishing Models	8-6
Livewells	8-6
Fishing Seats	8-7



TABLE OF CONTENTS

Barletta Coastal Edition	8-7
Corrosion Protection and Durability	8-7
Saltwater Ready Construction	8-7
Performance and Versatility	8-8
Maintenance and Longevity	8-8
Aesthetic and Branding	8-8
Power Bimini Top Instructions for Proper Operation	8-8
Full Open Position – Maximum Shade	8-8
Vari-Pitch Position – Shade During Low Sun	8-8
Radar Position – Rear Entry/Exit	8-9
Full Down Position – Lifts/Bridges/Storage	8-9
Arch Operation	8-9
JBL Powered Rallybar Option and Operation	8-9
Bimini Options	8-9
Bimini Boot	8-10
Symbols	8-11
Operating the Boat	9-1
Before Getting Underway	9-1
Safety Equipment	9-1
Float Plan	9-1
Pre-Departure Safety Checklist	9-1
Boarding	9-2
Using the Boarding Ladders	9-2
Boat Loading	9-2
Fueling	9-3
Fuel Management	9-3
Fuel Suppliers	9-3
Static Electricity and the Fuel System	9-3
Fuel (Gasoline)	9-4
Before Refueling	9-5
Refueling	9-5
Refueling Built-In Fuel Tanks	9-6
After Refueling	9-6
Getting Underway	9-6
Starting	9-6
Steering	9-6
Shifting	9-7
Stopping	9-7
Accelerating and Running Underway	9-8
Checks After Operation	9-9
Power Trim and Tilt	9-9
Power Trim	9-9
Performance Operation	9-10
Docking	9-11
Mooring	9-12
Covering	9-12
Cabana Enclosures	9-12
Anchors and Anchoring	9-12
Lines and Knots	9-14



Trailering and Launching10-1

 Legal Considerations10-1

 Trailer Classification10-1

 Trailer Type10-1

 Scissor-Style Trailer10-1

 Bunk-Style Trailer10-1

 Trailer Gross Vehicle Weight Rating10-1

 Towing Vehicle10-1

 Vehicle Towing Hitch10-2

 Hitch Ball and Trailer Coupler10-2

 Safety Chains10-3

 Trailer Brakes10-3

 5-Pin Wiring Connector10-3

 Trailering Guidelines10-3

 Engine-Transom Support Bracket10-3

 Pontoon Boat Considerations10-5

 Backing Up10-6

 Launching10-6

 Loading Guidelines10-7

 Reporting Safety Defects10-7

General Care and Maintenance11-1

 Safety Equipment11-1

 Life Jackets11-1

 Boating Equipment11-2

 Corrosion Protection11-2

 Galvanic Corrosion11-2

 Saltwater Corrosion11-2

 Aluminum pontoons and hulls11-3

 Sacrificial Anodes11-4

 Hardware, Fasteners and Fittings11-5

 Electrical System11-5

 Batteries11-5

 Circuit Breakers and Fuses11-6

 Motor Pod11-7

 Bilge Pump11-7

 Engine11-7

 Fuel System11-7

 Steering System11-7

 General Cleaning and Maintenance11-8

 Marine Growth11-8

 Cleaning11-8

 Pontoons11-8

 Aluminum Exterior Panels11-9

 Fiberglass Exterior Panels11-9

 Vinyl Upholstery11-9

 Vinyl Care and Cleaning Guide11-10

 Canvas Covers and Bimini Tops11-10

 Flooring11-10

 Non-Skid Flooring11-11

 Windshield11-11



TABLE OF CONTENTS

Mooring and Trailering Covers	11-11
Stainless Steel and Chrome Hardware	11-12
Aluminum Hardware	11-12
Trailer	11-12
Winterization and Storage.	12-1
Lifting	12-1
Winterization and Storage Preparation	12-1
Winterizing – Cleaning	12-2
Storing on a Cradle or Blocks	12-2
Storing on a Trailer	12-3
Storing During the Summer	12-3
Recommissioning After Storage	12-3
Troubleshooting.	13-1
Glossary of Nautical Terms.	14-1
Index	I-1



A NOTE FROM PRESIDENT, JEFF HARADINE

At Barletta Pontoon Boats, our focus will always be on YOU and how we can make our products and YOUR Barletta ownership exceptional. From the time you first come into contact with Barletta, until you join our family as an owner, Barletta has strived to build a world-class product and experience that will provide years of enjoyment with your loved ones.

WE ARE HONORED TO WELCOME YOU TO THE BARLETTA FAMILY.

A stylized, handwritten signature in black ink, consisting of several sweeping, connected strokes.

WE'VE GOT YOU COVERED.



WARRANTY

Barletta offers the industry's most comprehensive warranty including Limited Lifetime structural and 10 year bow-to-stern coverage.



SUMMER HOTLINE

After-hours support from our expert customer service team to keep you on the water during prime boating season.

BARLETTA CONSTRUCTION



V.I.P. TECHNOLOGY

Vibration Isolation Pads virtually eliminate any rattle or vibration you might experience where like metals meet.

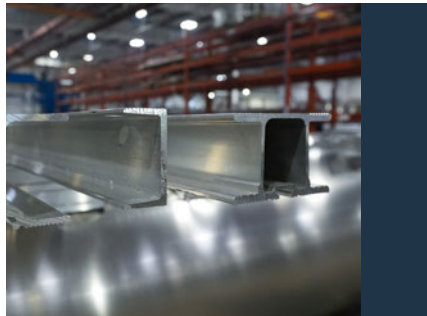

HYBRID CROSSMEMBERS

A hybrid combination of crossmembers creating the strongest deck structure in the industry.

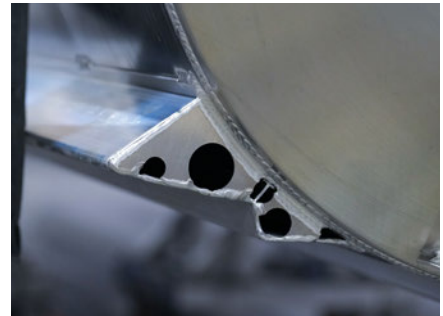

DUAL-STAGE LIFTING STRAKES

Designed to get you up on top of the water quickly and efficiently. Includes multi-species drainage ports.



FULL BELLY SKIN

Protects your underdeck from the water and the elements. It also keeps splashing water from affecting performance.



EXTENDED MOTOR POD

Better performance, better functionality and eliminates the need for tilt restrictors.

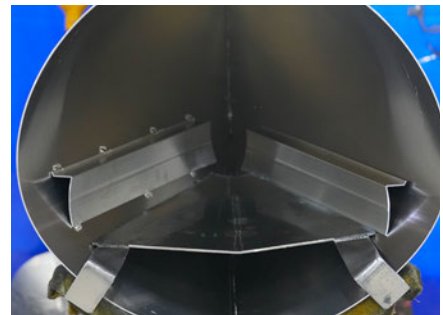

HEAVY DUTY NOSECONES

Built for big-water and higher horsepower applications, Barletta's nosecones are reinforced to help cut through the water.



CUSTOMER SATISFACTION

The CSI award honors manufacturers that maintain a 90% or higher in customer satisfaction for the year.

2018 | 2019 | 2020 | 2021 | 2022 | 2023 | 2024



WARRANTY

Barletta offers the industry's most comprehensive warranty including Limited Lifetime structural and 10 year bow-to-stern coverage.



PET FRIENDLY

No one gets left behind on the dock! Features for our four-legged friends include Doggie Dockview, integrated pet bowls, scratch-resistant vinyl, and EZ board ladders.



INNOVATION

Barletta is a four-time recipient of the NMMA innovation award recognizing manufacturers who bring new, innovative products to market.

2018 | 2023 | 2024 | 2025



SUMMER HOTLINE

After-hours support from our expert customer service team to keep owners on the water during prime boating season



5 ESTABLISHED PATENTS

Patents include proprietary chassis design, dual-stage lifting strakes, Doggie Dockview, Vibration Isolation Pad technology, and center-mounted twin engine.

Section 1

INTRODUCTION

ABOUT THIS MANUAL

This manual has been written as a general guide to safe operating practices, boating regulations and maintenance techniques for recreational boating. If this is your first time owning or operating a boat, it is recommended that you contact the boat dealer or local boating agency to find out how to enroll in a boater safety course prior to operating the boat.

This manual is not intended to be used as a replacement for specific information and procedures covered in manuals provided by the manufacturer of the engine, drive, accessories and other major equipment.

Because we are constantly working toward product improvement, this manual is intended to be a general guide only. The illustrations used in this manual may not match the equipment on the boat; they are intended only as general reference views.

This information is supplied with the understanding that the boat will be operated with good seamanship and attention to safe loading, safe operating conditions and safe speed. The manner in which the boat is loaded and operated is the responsibility of the operator.

IMPORTANT ITEMS TO NOTE ABOUT YOUR NEW BARLETTA



COVER YOUR BOAT WHEN NOT IN USE. We LOVE the sun, but just like us, your boat needs protection from too much exposure. UV rays are one of the harshest environments on the water. It is imperative that you keep your boat covered when not in use. Floors, furniture, helms, etc., will fade if not properly covered. Your warranty does NOT cover these items, so be sure to cover your boat when not in use.



PROPERLY LOAD BOAT. We get it, the more the merrier! However, proper loading of passengers and equipment on your new boat is critical to ensure optimal performance. Overloading one area of the boat may negatively affect performance. This includes leaning (tilt to one side or the other) or plowing (front of boat pushing further into the water, especially in choppy conditions).



RINSE YOUR BOAT (ESPECIALLY IF EXPOSED TO SALT ENVIRONMENTS). Salt can be extremely damaging and corrosive. If you are using your boat in saltwater conditions, it is highly recommended that you opt for the saltwater package. Even with that package, you **MUST** properly rinse your boat after each use. Remember that your warranty does NOT cover damage caused by salt due to neglect.



CLEAN YOUR PONTOONS OFTEN. Barnacles, algae, snails, we've seen it all. Believe it or not, these items can cause significant reduction in your boat's performance, even reductions of over 10 mph just from dirty pontoons. Clean them often to maximize performance.



BATTERY OPERATION. Most Barlettas come standard with a Battery ON/OFF switch. Some even have a Dual Battery Switch. Your electronics are very sensitive to low voltage drops that can cause all kinds of issues down the road including dead radios or other electronics. **Remember:** Your battery only charges when the engine is running and usually above 1000 rpm, unless plugged in to ShorePower, if that option is available. It's best to turn the battery switch OFF when not in use to avoid power drain and corrosion. Boats with a dual battery switch and Voltage Sensitive Relay (VSR) or sometimes referred to as Automatic Charging Relay (ACR) use a "Engine/Start" battery for starting and an "House" battery for electronics. When running the boat, set the switch to "On", the VSR will manage charging of both batteries. The "**Combined**" Position would be used in an emergency situation where one or both batteries are low, and power is needed from both batteries to start the engine. Once the engine has started, put the battery switch in "On" position (but not OFF) to direct all of the charging current to batteries. A healthy battery reads 12.5-12.8V, and anything below 11.8V is considered dead.



PROPER CLEANING. Just like Mom said, quick cleaning after each use will save you time in the long run. Wiping down surfaces or using a mild cleaner such as soap and water will not only ensure a long life but will also keep your boat looking its best on the water.



BOAT WON'T START. A systematic check is crucial. Verify the basics: fuel levels, battery connections, throttle position is in neutral, and the kill switch lanyard is attached. Other causes could include clogged fuel filters, bad spark plugs, water in the fuel, or a faulty starter. Finally, consider more complex problems such as low compression or mechanical or electrical failures. If all else fails, a quick call to your nearest dealer may be your best option.



SIMRADS, RADIOS, OR DISPLAYS. If your SIMRADs, radios, or displays stop working, start with the basics: ensure the battery is charged, terminals are clean and tight, the battery switch is ON, and the unit has not been dimmed. Check the master switch on the dash for the specific component, and inspect all fuses and breakers. Look for loose wiring at the battery, bus bar, or behind the device. Try power cycling the unit or performing a reset as outlined in the product manual. If issues persist, refer to the manual specific to that system.



PROPER BIMINI USE. Yes, we like to go fast too—just not with the Bimini up. The speed limit is 25 mph max with the Bimini up. Exceeding this can cause damage to the Bimini or power actuators. If your need for speed can't be tamed, we suggest investing in our Speed-top with optional Rainfly, available from your local Barletta dealer.



ABOUT YOUR NEW BOAT

BOAT TERMINOLOGY

It is important that you understand, learn and use appropriate and common nautical terminology while boating to ensure operator safety and the safety of others.

See the *Glossary of Nautical Terms* section of this manual for additional boating terminology.

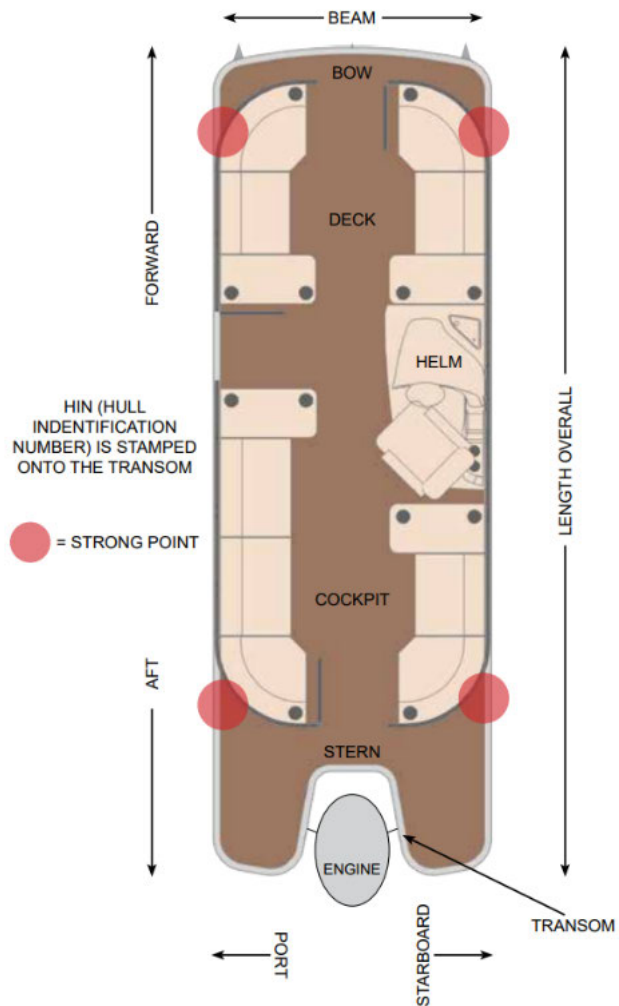
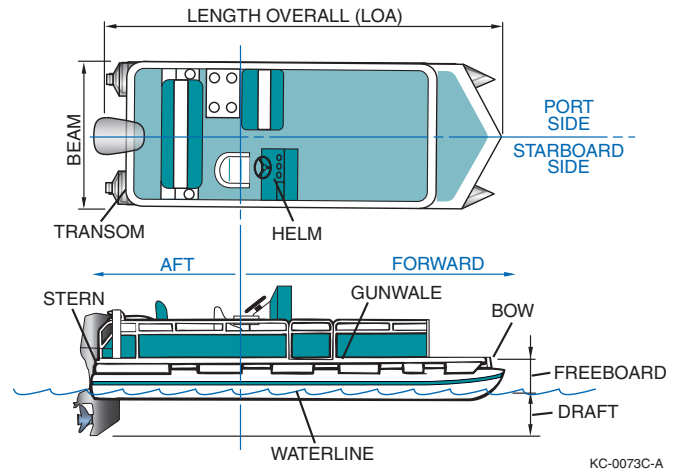

STRONG POINTS

Your boat is equipped with designated strong points that are designed to support the weight of the boat and engine for lifting the boat from the water.



SECTION
1

INTRODUCTION

HULL IDENTIFICATION, CAPACITY AND SAFETY PLATES

Hull Identification Number

The hull identification number (HIN) is usually located near the upper starboard corner of the transom on the outside of the boat. In some instances, the HIN may be located in an alternate location as determined by the manufacturer (e.g., a pontoon HIN may be located on the aft crossmember approximately 1 foot [0.3 meters] from the starboard hull attachment). The HIN must be clearly visible and may not be removed, altered or tampered with in any way as regulated by federal law.

In case of collision, theft or damage, report these numbers to the local authorities, the insurance agent and the dealer.

Safeguard information about the boat by recording the HIN and model of the boat, and model and serial numbers of the engine and accessories on the Boat Information Form in this manual.



U.S. Coast Guard Safety Standards Compliance Plate

All power boats less than 20 feet (6 meters) must have a manufacturer's compliance plate clearly indicating that the boat is in compliance with the U.S. Coast Guard (USCG) safety standards and the effective date of the compliance. The compliance plate may be combined onto one plate showing both the capacity plate and compliance information by the manufacturer.

As a division of the U.S. Department of Homeland Security, the USCG is the ultimate authority on U.S. waters. The USCG has the right to board any boat for any reason at any time. Failure to obey an order from the USCG can result in a fine, confiscation, imprisonment and even being fired upon in certain areas or conditions.

Certification Standards

The boat was built to meet federal USCG requirements and *may* be certified to more stringent American Boat & Yacht Council (ABYC) standards for the fuel, electrical, ventilation, flotation, horn, identification, capacity, placards and labels, powering, start-in-gear protection, navigation lights, backfire flame control and in most cases, fire extinguishers.

The boat owner is responsible for other USCG-required safety items, which can vary depending on the size of the boat as follows:

- Fire Extinguishers
- Life Jackets
- Visual Distress Signals
- Navigation Rules on board (Boats 39 feet 5 inches (12 meters) in length overall (LOA) and greater
- Audible Signaling Device. Boats greater than 65 feet (20 meters) in length must have a bell.

The boat manufacturer or dealer may provide some required safety items. Your boat *may not* be certified to ABYC standards; check the capacity plate for more information.

The person/load capacity is determined by the USCG. The capacity plate is usually located within clear visibility of the boat operator or helm area. The capacity plate indicates limits for loading the boat, which are enforceable by law. Never exceed the "U.S. Coast Guard Maximum Capacities" indicated on the capacity plate.



KCB-0008



Boats in the National Marine Manufacturers Association (NMMA) Certification program up to 26 feet (7.9 meters), or a pontoon boat of any length, are certified to ABYC standards, have the USCG maximum rated load capacity on the certification plate and may contain EPA and/or CARB emission information. Do not exceed maximum person or weight capacities. Add the weight of all persons on board; the total weight must not exceed the maximum weight capacity, so it is possible that fewer people than the maximum number can safely ride in the boat.

DESIGN CATEGORY

Boats over 26 feet are generally designed for use in typical conditions in inshore waters; Category C. Wave heights over 3 feet (1.0 m) make cruising uncomfortable. Waves over 6 feet (2.0 m) can be dangerous and should be avoided.

If you use your boat in the Great Lakes or ocean, you should confine your cruising to within 11 miles of the shore and constantly monitor the weather for changes. Few boats less than 65 feet are designed to be blue watercraft and as such can only be used if the water conditions are within the capabilities of the boat.

DISCLAIMER

This Owner's Manual is provided for information and educational purposes only and is not intended to offer or provide legal advice or create a contractual relationship. Please be aware that as a boat owner, you have responsibilities regarding the safety, maintenance, fitness and operation of the boat which cannot be delegated to anyone else. The extent of such responsibilities is ultimately determined by Federal law and regulations, the general maritime law of the United States, the laws and regulations of the states and territories of the United States, or the laws and regulations of the country where you operate the boat.

REFERENCES AND CONTACT INFORMATION

Use the following list of publications and organizations for reference and contact information concerning safe boating, navigational rules and other boating topics.

Publications

- Bottomley, Tom. *Boatman's Handbook*. Hearst Marine Book. Morrow
- Brotherton, Miner. *Twelve Volt Bible*. Seven Seas
- Calder, Nigel. *Boatowner's Mechanical and Electrical Manual*. McGraw-Hill Education
- Chapman, Charles F. and Maloney, E.S. *Chapman's Piloting, Seamanship and Small Boat Handling*. Hearst Marine Book. Morrow
- Hinz, Earl. *The Complete Book of Anchoring and Mooring*. Cornell Maritime Press
- National Fire Protection Association. *NFPA 302 Fire Protection Standard for Pleasure and Commercial Motor Craft*. National Fire Protection Association
- United States Coast Guard. *Navigational Rules for U.S. Waterways*. Visit <https://www.navcen.uscg.gov/> to view or download this publication.
- United States Coast Guard Auxiliary. *Boating Skills and Seamanship Thirteenth Edition*. United States Coast Guard
- Whiting, John and Bottomley, Tom. *Chapman's Log and Owner's Manual*. Hearst Marine Book

Organizations

American Boat & Yacht Council

Boat building standards.
<http://abycinc.org>

American Red Cross

A resource for first aid training, emergency supplies and preparedness.
<http://www.redcross.org> or consult the local telephone directory

Boat Owners Association of The United States

Organization of recreational boaters offering marine services, education and protecting boater's rights.
<http://www.boatus.com/>



SECTION
1

INTRODUCTION

BoatU.S. Foundation for Boating Safety Hotline

Training and education outreach directly to boaters.
<http://www.boatus.org/>
Phone: 800-245-2628

National Association of State Boating Law Administrators

Boat safety training and education resources.
<http://www.nasbla.org>

National Marine Manufacturers Association

Boat, marine engine and accessory manufacturer trade association.
<http://www.nmma.org>

National Oceanic and Atmospheric Administration's National Weather Service

Nautical charting, weather, fishery, ocean and climate resources.
<http://www.noaa.gov>

National Safe Boating Council, Inc.

<http://www.safeboatingcouncil.org>

Sea Tow Services International, Inc.

Organization of recreational boaters providing towing and more.
<http://www.seatow.com>
Toll free: 800-473-2869

U.S. Coast Guard

<http://www.uscgboating.org> (To contact the U.S. Coast Guard for an emergency while on the water, always use the onboard VHF-FM radio channel 16. Use cell phones only as a secondary means of communication. Call 9-1-1 to reach rescue personnel.)

U.S. Coast Guard Auxiliary

Information on boating safety classes and boat safety checks.
<http://nws.cgaux.org>; Phone: 877-875-6296

U.S. Coast Guard Navigation Center (NAVCEN)

USCG navigation information.
<https://www.navcen.uscg.gov>

U.S. Coast Guard Office of Boating Safety

USCG resources for recreational boaters.
<http://www.uscgboating.org>

U.S. Coast Guard's America's Waterway Watch Program

A program for recreational boaters to assist the U.S. Department of Homeland Security in reporting suspicious activity on U.S. waterways;
Phone: 877-249-2824

U.S. Government Publishing Office

<http://www.gpo.gov>
(For information and documentation on FCC rules and regulations and Skippers Course information, and other government, marine and nautical related documents)

U.S. Power Squadrons

Boating courses and knowledge resources.
<http://www.usps.org>; Phone: 888-367-8777

Water Sports Industry Association

Water sports education, safety and risk management.
<http://www.wsia.net>



BOAT INFORMATION FORM

BOAT	
Boat Manufacturer:	
Hull Colors:	
Weight:	
Length:	
Draft:	
Beam:	
Vertical Clearance:	
Dealer:	
Dealer Representative:	
Dealer Phone:	
Boat Model:	
Hull ID Number (HIN):	
Registration Number:	
Registration State:	
Purchase Date:	
Delivery Date:	
Warranty Expiration Date:	
Manufacturer Representative:	
Manufacturer Phone:	
ENGINE, DRIVE AND PROPELLER	
Engine Make:	
Engine Model Number:	
Engine Serial Number:	
Ignition Key Number:	
Drive Make:	
Drive Model Number:	
Drive Serial Number:	
Propeller	Make/Type:
	Size/Material:
	Part Number:
SYSTEMS	
Fuel Filter Part Number:	
Battery Make:	
Battery Size:	



SECTION
1

INTRODUCTION

ACCESSORIES

Manufacturer:

Model:

Serial Number:

Manufacturer:

Model:

Serial Number:

Manufacturer:

Model:

Serial Number:

Manufacturer:

Model:

Serial Number:

Manufacturer:

Model:

Serial Number:

TRAILER

Trailer **Make:**

Model Number:

Serial Number:

GVWR:

Tire Size:

Section 2

SAFETY

The popularity of boating and other water sports has undergone an explosion of growth in the past few years, making safety an important issue for everyone who shares in the use of the waterways.

⚠ WARNING *Operation Hazard: Read and understand this Basic Boating and Safety Manual, the Engine Operator's Manual and all manufacturer-supplied information regarding the operation of equipment. The boat operator must understand all safety information responsibilities, regulations, controls and operating instructions before attempting to operate the boat. Improper operation could result in death or serious injury.*

The safety content and precautions listed in this manual and on the boat are not all-inclusive. If a procedure, method, tool or part is not specifically recommended, the operator must feel confident that it is safe for them and others, and that the boat will not be damaged or become unsafe as a result of the operator's decision. REMEMBER – ALWAYS ASSESS EACH SITUATION AND USE SOUND JUDGMENT!

The boat operator is responsible for their own safety, as well as that of passengers and other boaters.

GOOD SAFETY PRACTICES

Boating-related accidents are generally caused by the operator's failure to follow basic safety rules or written precautions. Most accidents can be avoided if the operator is completely familiar with the boat, its operation and the navigational rules of the road and can recognize potentially hazardous situations.

In addition to everyday safety, failure to observe safety recommendations may result in severe personal injury or death to the operator or to others. Use caution and sound judgment when operating the boat. Do not take unnecessary chances! Failure to adhere to these warnings could result in death or severe injury to the operator and/or others.

Read this entire manual and be aware of other specific safety guidelines not listed in this manual. Seek additional safety information from the USCG and state and local authorities. In addition to specific safety statements noted in this manual, a general list of safety guidelines and recommendations is listed below:

- The boat must comply with USCG safety equipment regulations.
- Before each outing, check all safety equipment such as fire extinguishers, life jackets, flares, distress flags, flashlights and engine cut-off switch. Make sure they are operable, in good condition, readily visible and easily accessed.
- Onboard equipment must always conform to the governing federal, state and local regulations.
- Never allow any type of spark or open flame on board. It may result in fire or explosion.
- Take the keys/FOBs when leaving the boat to keep untrained and unauthorized persons from operating the boat.
- Know how to react correctly to adverse weather conditions, have good navigation skills and follow navigational rules as defined by USCG, state and local regulations.
- Check local weather reports before casting off. Do not leave the dock area when strong winds and electrical storms are in the area or predicted to be in the area.
- Seek shelter from open water if lightning is an imminent threat.
- Tell someone of the travel plans before departing.
- Know the weight capacity of the boat. Never overload the boat.
- Never operate the boat while under the influence of drugs or alcohol.
- Look before turning the boat. The boater is obligated to maintain a course and speed unless it is safe to alter course and speed. Look before turning.
- Operators must read and understand all operating manuals supplied with the boat before operation.
- Whenever planning an outing, make sure that at least one passenger is familiar with the operation and safety aspects of the boat in case of emergency.



- Passengers should never sit in front of the operator; always avoid obstructing the operator's view.
- Show all passengers the location of emergency equipment and explain how to use it.
- Never allow passengers to drag their feet or hands in the water, or sit on the bow, bow pulpit, railing, deck or gunwale while the engine is running.
- Never use or hold on to the boarding platform while the engine is running.
- Never stand or allow passengers to stand in the boat or sit on the transom, seat backs, engine cover or sides of the boat while the engine is running. The operator or others may be thrown from the boat.
- Children and nonswimmers must wear a life jacket at all times.
- Never leave children in the boat without adult supervision.
- Improper operation of the boat is extremely dangerous.
- Securely attach the engine cut-off switch lanyard around your leg or to a part of your clothing such as a belt loop, when operating the boat. Instruct others on how to start the boat if you as an operator are thrown overboard. Consider having an extra lanyard or other rearming device readily available on board since the system cannot be overridden without the lanyard that is on the person who is now overboard.
- Operate slowly in congested areas such as marinas and mooring areas.
- The bow may be slippery. Do not go forward while the engine is running.
- Slow down when crossing waves or wake in order to minimize the impact on passengers and the boat.
- Never replace the boat's marine parts with automotive parts (if applicable).
- Never remove or modify any components of the fuel system. Always have qualified personnel perform fuel system maintenance. Tampering with fuel components may cause a hazardous condition.
- Avoid contact with engine exhaust gases—engine exhaust contains carbon monoxide.
- Never operate the engine in a confined space.
- Never go under the boat cover with the engine running or shortly after the engine has been running.
- Allow adequate ventilation with fresh air before entering any enclosed areas.
- Watch for other boats, swimmers and obstructions in the water. Stay away from other boats and personal watercraft (PWCs).
- Never swim near a boat when the engine is running. Even if the boat is in the NEUTRAL position, the propeller may still be turning and carbon monoxide may be present.
- Never dive from the boat without being absolutely sure of the depth of the water; severe injury or death may occur from striking the bottom or submerged objects.
- Never wrap ski lines or mooring lines around any body part. You could become entangled in the line if you fall overboard while the boat is moving.
- Keep track of ski lines and dock lines so they do not become entangled in the propeller.
- Have an experienced operator at the helm and always have at least three people present for safe towing—one to drive, one to observe, and one to ski or ride.

SAFETY AND TRAINING

There is a vast amount of recreational boating regulatory, safety and training information online, and much of it is free. This information covers laws, aids to navigation, rules of the road, hands-on boating safety courses, boat safety checks and much more for both novices and experienced boaters. Go to the following sites for more information:

- United States Coast Guard
www.uscgboating.org
- United States Power Squadron
www.usps.org
- BoatU.S. Foundation
www.boatus.org



SAFETY LABELS

The boat is affixed with various hazard and safety labels at the time of manufacture. These labels appear in specific locations on the boat and on equipment where safety is of particular concern. All operators of the boat must read and understand all hazard and safety labels and advise all passengers on the safety concerns and proper practices. Hazard and safety labels must remain legible. If the operator suspects a label is missing or damaged they should contact the dealer for replacement.

SAFETY STATEMENTS

There is no substitute for sound judgment and careful practices. Improper practices or carelessness can cause burns, cuts, mutilation, asphyxiation, other bodily injury or death. This information contains general safety precautions and guidelines that must be followed to reduce risk to personal safety. Special safety precautions are listed in specific procedures. Read and understand all of the safety precautions before operation or performing repairs or maintenance.



NOTE — This safety alert symbol appears with most safety statements. It means attention, become alert, your safety is involved! Please read and abide by the message that follows the safety alert symbol.

! DANGER Indicates a hazardous situation that, if not avoided, will result in death or serious injury.

! WARNING Indicates a hazardous situation that, if not avoided, could result in death or serious injury.

! CAUTION Indicates a hazardous situation that, if not avoided, could result in minor or moderate injury.

NOTICE Indicates a situation that can cause damage to the boat and accessories and/or the environment, or cause the equipment to operate improperly.

BARLETTA SAFETY TAGS



DO NOT SIT ON GATE
To open, lift here & swing in

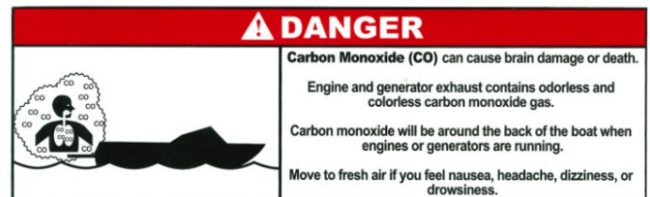
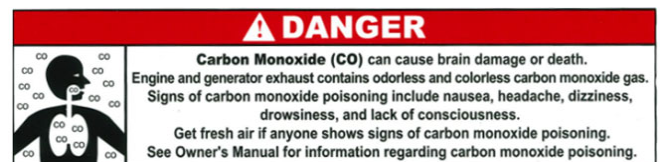

**WARNING**

FUEL SYSTEM UNDER PRESSURE
Release cap slowly to avoid injury.
No smoking, vapors are combustible.

CAUTION

Avoid blow back when filling the fuel tank on the initial fill. Fill the tank **SLOWLY** for the first several gallons.

WARNING

To avoid personal injury, do not use this as a grab handle.

WARNING

Avoid personal injury. Do not sit in front of rails and stay inside of deck rails when boat is underway. Avoid the risk of falling into water and being struck by hull or propeller.



Exhaust Hazard: Carbon monoxide (CO) is a colorless and odorless gas produced by all engines, fuel-burning appliances and any material that contains carbon and is burned. Direct or prolonged exposure to carbon monoxide will cause brain damage or death.



Electrocution Hazard: Docks and other boats nearby can carry sources of electricity. Faulty wiring or the use of damaged electrical cords and other devices not approved as “shore or marine rated” can cause the surrounding water source to become energized from electricity leakage. Never enter the water or swim in a marina.



WARNING The safety messages that follow have **WARNING** level hazards. These safety messages describe hazardous situations that, if not avoided, could result in death or serious injury.



Fire/Explosion Hazard: Gasoline is extremely flammable and highly explosive under certain conditions.

- **Compartments for fuel, flammable liquids or gases must be properly ventilated to prevent explosive vapors from accumulating. Most vapors are heavier than air. If not in a vapor-tight locker vented overboard, vapors will accumulate in the bilge, posing a fire and explosion hazard.**
- **Inspect fuel system for leaks at least once a year.**



Fire/Explosion Hazard: Hydrogen gases produced by a lead-acid battery while it is charging, or the engine is running, can cause an explosion and/or a fire.

- **Always wear personal protective equipment when working on or around batteries.**
- **Keep the area around the battery well-ventilated.**
- **Do not smoke or bring an open flame or any other form of ignition near a battery.**
- **Do not check for a dead battery by placing a metal object between the battery posts. Sparks could cause an explosion.**
- **Do not place your head directly above a battery when making or breaking electrical connections.**

SAFETY PRECAUTIONS**DANGER**

The safety messages that follow have **DANGER** level hazards. These safety messages describe hazardous situations that, if not avoided, will result in death or serious injury.



Training Hazard: Do not permit anyone to launch, operate or retrieve the boat without proper training.

- **Read and understand this Basic Boating and Safety Manual and all manufacturer-supplied information before operating or servicing the boat to ensure that you follow safe operating practices and maintenance procedures.**
- **Safety signs and labels are additional reminders for safe operating and maintenance techniques.**
- **See the boat dealer for additional training.**



- Always charge the battery outside of the boat.
- Do not use a battery booster to start the engine.



Sever Hazard: Make sure nobody is near the propeller before starting the engine(s).

- Do not allow swimmers to approach or use the ladder when the engine is running.
- The operator should walk to the stern and check the water for people near the propeller, as people in the water may not always be noticeable from the helm.
- Turn off the engine(s) before allowing people to board or exit the boat. The propeller may continue rotating even when the engine is idling or in NEUTRAL.
- Show passengers the location of the propeller and teach them to keep their distance from it at all times, even when the propeller is not in motion.
- Show passengers the propeller warning labels around the boat and discuss propeller dangers.
- Be particularly alert when boating in high-traffic areas and never operate in swimming zones.
- Exercise caution when operating near boats that are towing skiers and tubers.
- Never allow passengers to sit in areas where they could fall overboard, including the bow, gunwale, transom, seat backs, or other locations.
- Carefully watch children aboard the boat at all times.
- Instruct passengers on the rules for using the swim platform, boarding ladders and seats. If possible, instruct them to stay seated at all times while the engine is running.



Man Overboard Hazard: Always remain seated in the boat manufacturer's designated seating arrangement, use handholds and never block the view of the boat operator while underway. The boat's bow, gunwale, transom platform and seat backs are not intended for use while underway.

- If someone falls overboard, slowly turn the boat around while keeping an eye on the victim. Ask a passenger to help monitor the victim. Always STOP THE ENGINE before rescuing a victim from the water.
- Never put the engine in REVERSE to retrieve a person from the water. Slowly circle back to the person again if necessary.



Entanglement Hazard: Rotating or moving parts can entangle or sever body parts.

- Do not wear jewelry, unbuttoned cuffs, ties or loose-fitting clothing.
- Tie long hair back when working near moving or rotating parts such as the flywheel or propeller shaft.
- Keep hands, feet and tools away from all moving parts.
- Keep all guards in place when the engine is operating.
- Use caution when working with ski or mooring lines so they do not become entangled with the propeller.



Exposure Hazard: Wear personal protective equipment, including appropriate clothing, gloves, work shoes, eye and hearing protection, as required by the current task.



Control Hazard: Do not operate the boat while you are under the influence of alcohol or drugs or if feeling ill. Federal laws prohibit operating a boat under the influence of alcohol or drugs. These laws are vigorously enforced.



CAUTION *The safety messages that follow have CAUTION level hazards. These safety messages describe hazardous situations that, if not avoided, could result in minor or moderate injury.*



Slip/Trip Hazard: *Keep the boat free of water, oil, mud and other foreign matter. Do not wax deck and swim platform surfaces. Remove anything that creates slippery areas around the boat.*

NOTICE

The safety messages that follow have NOTICE level hazards. These messages are used to indicate a situation that can cause damage to the boat and accessories and/or the environment, or cause the equipment to operate improperly.

- *Unapproved modifications to the boat or systems may impair the boat's safety and performance characteristics and shorten the boat's life. Any alterations to the boat may void its warranty. Always consult the boat manufacturer before making modifications or adding equipment.*
- *ALWAYS be environmentally responsible. Follow the guidelines of the EPA or other governmental agencies for the proper disposal of hazardous materials such as engine oil and fuel. Collect all trash and dispose properly on shore. Keep our waters clean! Consult the local authorities or reclamation facility.*

Carbon Monoxide (CO)



DANGER *Exhaust Hazard: CO gas is colorless, odorless and extremely dangerous. All engines and fuel-burning appliances produce CO as exhaust. Direct and prolonged exposure to CO will cause brain damage or death. Always avoid exposing your passengers or yourself to CO.*

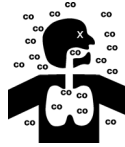

Even with the best boat design and construction, plus the utmost care in inspection, operation and maintenance, hazardous levels of CO may still be present in accommodation areas under certain conditions. To reduce CO accumulation, always provide adequate ventilation in the boat interior by opening the deck hatches, windows or canvas.

Do not confuse carbon monoxide poisoning with seasickness, intoxication or heat stress. If someone complains of irritated eyes, headache, nausea, weakness, dizziness or drowsiness, or you suspect carbon monoxide poisoning, immediately move the person to fresh air, investigate the cause and take corrective action. Seek medical attention if necessary.

Always use a CO detector in confined areas where there is a possibility of CO buildup, such as enclosed canvas, sleeping quarters, galleys and head compartments. Regularly check the condition of the CO detector for proper operation.

Make sure that all passengers know what the CO detector alarm sounds like. If the alarm sounds, shut down engines and generator, move passengers to fresh air for at least 10 minutes, reset the alarm and investigate the cause. Ventilate the space thoroughly before restarting engines and generator.

Test the carbon monoxide detector operation before each trip, at least once a week and after the boat has been in storage. Also have the CO detectors professionally tested at regular intervals. Most CO detectors are required to be replaced every 5 years – see the OEM manual.



Potential Causes of CO Poisoning While Underway

Blockage of boat exhaust by obstruction

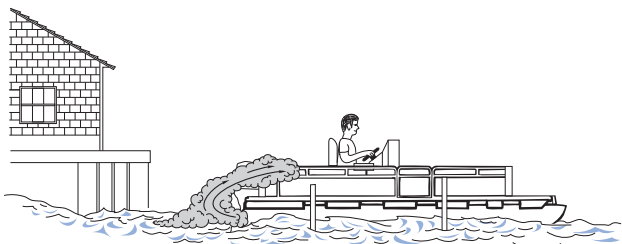

KC-0237-A

Exhaust from other vessels in confined areas

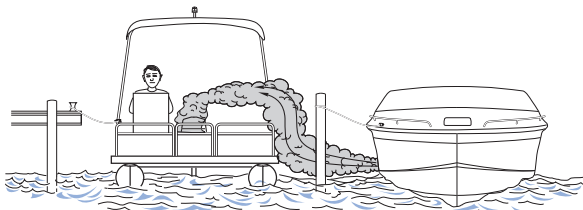

KC-0240-A

Operating at a high bow angle



KC-0238-A

Operating at slow speed or while idling



KC-0241-A

Exhaust traveling along obstruction

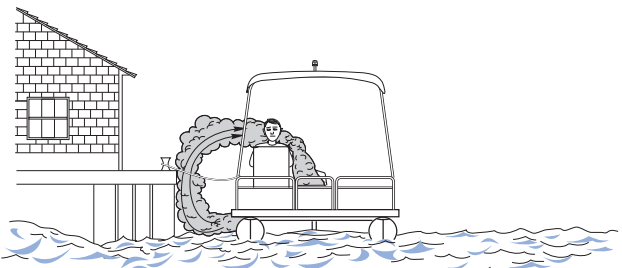

KC-0239-A

Operating with canvas tops and side curtains in place without ventilation



KC-0242-A

Always ensure adequate fresh air ventilation through the boat when underway.

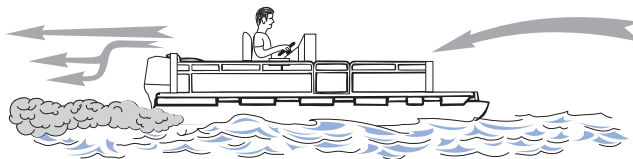

KC-0306-A

KC-0300-C

REQUIRED BOATING SAFETY EQUIPMENT AND REGULATIONS

U.S. Coast Guard Minimum Onboard Safety Equipment Required

(The boat may be equipped with one or more requirements by the manufacturer, but it is the boat owner's responsibility to have these items on board.)

	LESS THAN 16 FT (4.9 M)	CLASS 1: 16 TO LESS THAN 26 FT (4.9 TO LESS THAN 7.9 M)	CLASS 2: 26 TO LESS THAN 40 FT (7.9 TO LESS THAN 12.2 M)	CLASS 3: 40 TO 65 FT (12.2 TO 19.8 M)
LIFE JACKETS AND PERSONAL FLOTATION DEVICES (PFDs)	One U.S. Coast Guard-approved wearable life jacket for each person on board	One U.S. Coast Guard-approved wearable life jacket for each person on board and one throwable PFD device		
VISUAL DISTRESS SIGNALING (VDS) DEVICES	One (1) electric distress light OR three (3) day and night combination red flares	One orange distress flag or one electric distress light OR three floating or handheld orange smoke signals and one electric distress light OR three day and night combination red flares, handheld, parachute or meteor type		
AUDIBLE SIGNALING DEVICES	A boat less than 39.4 ft (12 m) must have on board an efficient sound-producing device. (Example: hand or mouth whistle OR a compressed or powered air horn)			A boat 39.4 ft (12 m) but less than 65.6 ft (20 m) in length operating in inland waterways must carry a power whistle OR powered air horn AND a bell
NAVIGATION LIGHTS	Regulations require that navigational lights be clearly lit and properly displayed at all times between sunset and sunrise and always when operating in reduced visibility while boating			
FIRE EXTINGUISHERS	<p>One 5-B type (U.S. Coast Guard-approved)</p> <p>If the boat meets any one or more of the following conditions, the boat must carry one 5-B type USCG-approved extinguisher on board:</p> <ul style="list-style-type: none"> • Inboard/sterndrive engine powered • Has closed compartments where portable fuel tanks can be stored • Has double bottom construction that has areas where air or gases can be open or trapped • Has an enclosed living space • Has compartments where flammable, combustible or explosive materials are stored • Has permanent fuel tanks installed • Boat is 26 ft (7.9 m) or more in length 	One 20-B OR two 5-B type (USCG-approved) (A fixed extinguishing system is equal to one 5-B.)	One 20-B AND one 5-B OR three 5-B type (USCG-approved) (A fixed extinguishing system is equal to one 5-B.)	
ENGINE CUT-OFF SWITCH	Powered boats less than 26' (7.9 m) operating in Federal waters must be equipped with an engine cut-off switch and operator interface.			



FIRE EXTINGUISHER

USCG-approved fire extinguishers are required on all Class I, II and III boats. Mount all handheld fire extinguishers in readily accessible areas away from the engine compartment and other combustible devices. All passengers must know the location and operating procedure of each extinguisher. Follow the manufacturer's instructions for proper use and operation of the fire extinguisher.



All fire extinguishers used on marine boats must be classified to extinguish type B fires (gasoline, oil or grease). The size and number of required fire extinguishers depend on the size of the boat. The two type B fire extinguishers commonly used are 5-B and 20-B. Type B fire extinguishers are classified by the different extinguishing compound amounts used in each.

Check the fire extinguisher condition and pressure gauge regularly, if not before every trip, to ensure that the fire extinguisher is in good operating condition and is fully charged. If the fire extinguisher is damaged or not properly pressurized, replace it. Disposable (non-rechargeable) fire extinguishers with a date of manufacture stamped on the bottle older than 12 years must be removed from service and no longer count towards the minimum carriage requirements. Expired extinguishers may be carried aboard for backup if they are otherwise still in good operating condition.

See the *U.S. Coast Guard Minimum Onboard Personal Safety Equipment Required* section of this manual for specific onboard requirements.

ENGINE CUT-OFF SWITCH AND LINK

The engine cut-off switch (ECOS) is an extremely important safety device. The engine cut-off switch link (ECOSL) is a device which connects the operator to the engine cut-off switch. This may be a physical lanyard or an electronic fob. Use the engine cut-off switch when operating the boat's engine.

These safety devices prevent the boat from becoming a runaway if the operator is accidentally thrown from the seat or away from the helm. The USCG recommends and many states require the use of the cut-off switch by law. Check with local and state authorities about usage requirements to avoid potential fines.

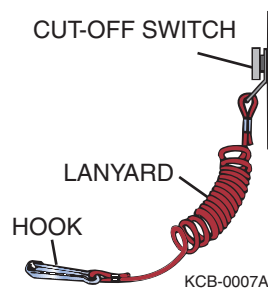

Starting April 1, 2021, individuals operating most types of powered boats less than 26' (7.9 m) in Federal waters are required to use an engine cut-off switch and lanyard while the boat is on plane or above displacement speed.

- Tiller-steered models may have a switch mounted on the tiller handle with a wrist lanyard.
- Side-mount controls may have a switch on the control box with a "clip-on" lanyard.
- Larger boats may have a helm-mounted switch with a "clip-on" lanyard.
- Some boats may have a wireless switch with an electronic FOB attached to the operator.

Consider having an extra lanyard or other rearming device readily available on board since the system cannot be overridden without the lanyard that is on the person who is now overboard. Rearming or bypassing the engine cut-off switch should not require continuous input from the operator.

⚠ WARNING *Control Hazard: Never remove or modify the engine cut-off switch and/or lanyard.*

- **Always check the switch for proper operation. With the engine running in neutral, pull the lanyard. If the engine does not stop, have the switch repaired before continuing to operate the boat. Never operate the boat if the engine cut-off switch does not work.**
- **Avoid accidentally pulling the cord lanyard during normal operation. Loss of engine power means loss of most steering control. Also, without engine power, the boat could slow rapidly. This could cause people and objects in the boat to be thrown forward.**

LIFE JACKETS

Boaters enjoy the feel of sun and spray, so it's tempting to boat without wearing a life jacket, especially on nice days. However, the failure to wear life jackets is by far the number one cause of boating fatalities.

Modern life jackets are available in a wide variety of shapes, colors, sizes and technologies. Many are thin and flexible. Some are built right into fishing vests or hunter coats. Others are inflatable and as compact as a scarf or fanny pack until they hit water and automatically fill with air. Ensure all passengers on board understand where the life jackets are located and how to put them on and use them.



There's no excuse for not wearing a life jacket on the water. Boat dealers or marine stores are the best sources for guidance when selecting this most important piece of safety equipment.

Starting in 2020, the U.S. Coast Guard working in cooperation with Transport Canada started transitioning to new life jacket labeling based on a performance classification system acceptable in both countries. If you have older approved life jackets, devices are approved in one country or the other, but not both. U.S.-approved devices are still acceptable in the U.S., and Canadian-approved devices are still acceptable in Canada when used in accordance with the approval label.

Always check and read the manufacturer's information booklet and label provided with all new life jackets. They will provide valuable information, including size, type, intended use, approval, inspection, and care information. For more information, go to <http://wearitlifejacket.com/>.

Things to Know about Life Jackets:

- Life jackets are now classified as wearable or throwable on the label.
- We recommend that all boaters and passengers wear a life jacket at all times while boating.
- Certain life jackets are designed to keep the head above water and help you remain in a position that permits proper breathing.
- To meet USCG requirements, a boat must have an approved life jacket for each person aboard. Boats 16 feet (4.9 meters) and over must have at least one throwable device as well.
- All states have regulations regarding children wearing life jackets. Special life jackets for children are available and based on the weight of the child.
- Adult-sized life jackets will not work for children. To work correctly, a life jacket must be worn, fit snugly and not allow the child's chin or ears to slip through.
- Test life jackets for wear and buoyancy at least once each year. Discard waterlogged, faded, leaky or damaged jackets.
- Properly stow life jackets but make them easily accessible.

- A life jacket, especially a snug-fitting flotation coat or deck-suit style jacket, can help people survive in cold water.
- Various types of life jackets are also available for pets.
- A life jacket can save a boater's life, but only if the boater wears it. Set the example and wear it whenever near the water.

Life Jackets Must Be:

- New jackets must be USCG or Transport Canada approved
- In good and serviceable condition
- Appropriately sized for the intended user
- Appropriate for the water activity
- Snug-fitting
- The best life jacket is the one you will wear

Accessibility

- Throwable devices must be immediately available for use in emergency situations.
- Wearable life jackets must be readily accessible.
- Boaters must be able to locate and put them on in a reasonable amount of time in an emergency.
- They should not be stowed in plastic bags, in locked or closed compartments, or have other gear stowed on top of them.

Child Life Jacket Federal Requirements

No person may operate a recreational boat underway with any child under 13 years old aboard unless each such child is either: (1) Wearing an appropriate PFD approved by the Coast Guard; or (2) Below decks or in an enclosed cabin.



SCAN ME VIDEO

KCB-0130

Some states require that children wear life jackets at all times; check with the state boating safety authorities.

Since children grow quickly, many boat launches now feature free use of children's life jackets in several different weight categories.



Life Jacket Requirements for Certain Boating Activities Under State Laws

The USCG recommends, and many states require, wearing USCG-approved life jackets:

- For waterskiing and other towed/surf activities, use a life jacket designed for waterskiing. **It is illegal in many states to participate in towed water sports without a USCG-approved life jacket. Be aware that some specialized water sports vests are NOT USCG-approved and should be worn in addition to a USCG-approved life jacket.**
- While operating personal watercraft (PWC) use a life jacket marked for PWC or waterskiing use.

Check with the state boating safety authorities. Other rules may apply if boating in an area under the jurisdiction of the Army Corps of Engineers or a federal, state or local park authority. Special local rules are usually posted at the boat launch.

The new life jacket labels make it easier for the boat owner to choose the appropriate sizes and types of jackets for the boat. Labels may be in English, French Canadian or both languages depending on where they are marketed, but all will use icons for key performance indicators.

Size

Chest size is used on ADULT devices to further define the fit not used on all others. Weight is used to define the basic size groups of:

- INFANT <30 LBS
- CHILD 30-50 LBS
- YOUTH 50-90 LBS
- ADULT >90 LBS

Performance Level

The performance level indicates the amount of floatation provided. The higher the number, the more floatation at the increase in bulk.

- Lower numbers are more comfortable to wear and are a good choice for near-shore, calm water boating.
- Mid numbers offer more stability for people who do not swim and for novice swimmers and are a better choice for coastal boating.
- Higher numbers have the greatest floatation and are the best choice for remote areas where rescue times may be long, for non-swimmers, and for offshore use.

Turnability

Typically, jackets with low performance levels will not turn an unconscious person face-up. Jackets with mid performance levels may not turn an unconscious person face-up. Jackets with high performance levels will turn an unconscious person face-up.

Warnings

Some life jackets are not approved for waterskiing, tubing, wakeboarding, white-water paddling, or use on a personal watercraft.

Find More Information

Additional information on the life jacket in the owner's manual and web sources.

Manufacturer and Approval Information

Manufacturer's information for possible future recalls. USCG approval number and certification agency to assure the jacket meets the law and is safe to use.

Use, Care and Storage Information

A summary of the use, care and storage information contained in the owner's manual.



SECTION
2

SAFETY

ADULT UNIVERSAL
User Weight: > 41kg (>90 lbs)
Chest Size: 76-132 cm (30-52 in.)

70

TURNABILITY

WARNINGS ON USE

- Approved only when worn
- Drowning hazard if not worn.
- Must be fastened and properly adjusted to float the wearer.

Choose and wear the device which fits you and your activity, visit www.XXXXX.com*
Read and keep the owner's manual and tags for info on wear and care.

Company Name
Company Address
Company website if available
Indication of Country of Origin
USCG Approved 160.064/XXXXXX
ANSRUL 1123- TYPE III
Model:
Lot No.

Lab Certification Mark
Certifying Lab Identification and Address

Use:
Fasten all closures and adjust for a snug fit.
Inspection:
Inspect your life vest before each outing. Do not use if your life vest shows signs of weathering, damage, or rot.
Care and Storage:
Dry thoroughly after each outing.
Store in a dry cool place out of direct sunlight.

KCB-0129

Inflatable Life Jackets

U.S. Coast Guard-approved inflatable life jackets are authorized for use by persons 16 years of age and older (check the label).

- They require regular maintenance. Also, pay attention to the condition of the inflator.
- They must have a full cylinder and all status indicators on the inflator must be green. If all status indicators are not green, the device is not serviceable and does not satisfy the legal requirements for the wearable life jacket carriage requirement.
- They must be worn at all times.



VISUAL DISTRESS SIGNALING (VDS) DEVICES

There are a variety of VDS devices for day, night, or day and night use. Pyrotechnic devices can be dangerous if used improperly; read the instructions before using. Pyrotechnic devices expire and must be replaced every few years, as stamped on the unit. Be sure to properly dispose of old pyrotechnics.

Distress lights and strobes are equipped with batteries that must be replaced every few years, as stamped on the unit.

Advancements in technology have led to a number of electronic VDS devices (eVDSD). These devices are battery-powered and contain one or more LED lights and possibly other features. While eVDSDs are not “USCG Approved,” they are accepted as “equivalent” if compliant with RTCM Standard 13200.0 for nighttime use. Several can be equipped with a VDS flag for day/night use and/or a whistle for audible signaling. Talk to your boat dealer about the best device for your use and to obtain that device.

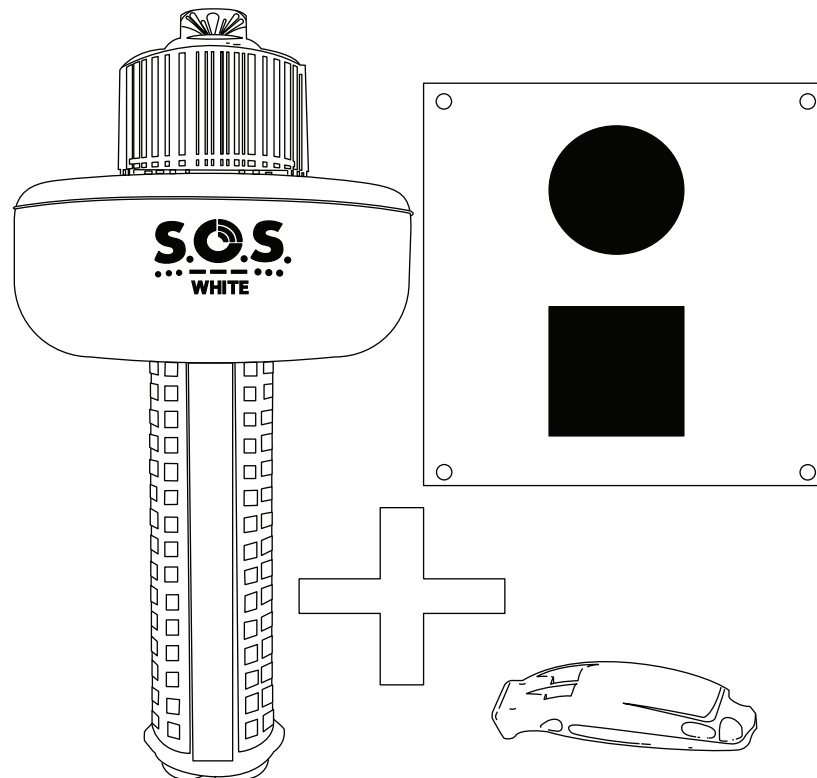

KCB-0131

Boats less than 16 feet (4.9 meters) must have USCG-approved visual distress signals (VDS) on board when operating between sunset and sunrise in coastal waters, including ocean bays, gulfs and sounds, as well as the Great Lakes, seas, bays and river mouths that are 2 or more miles wide and only to the point proceeding inland where the water narrows to less than 2 miles. Visit the U.S. Coast Guard website for additional information on specific VDS requirements for the boat.

Ensure all passengers on board understand how to operate all VDS. Keep VDS in a readily accessible area and within immediate reach at all times when boating.



VISUAL DISTRESS SIGNALS

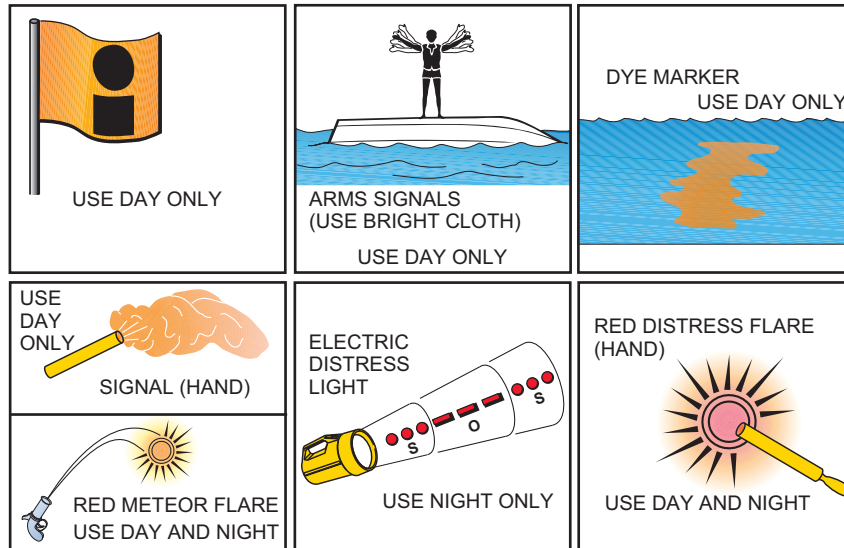

KC-0008C-B

Regulations prohibit using pyrotechnic VDS or any VDS in non-emergency situations.

VDS must be:

- USCG-approved
- In proper operating condition
- Safely stowed and readily available
- Within the clearly marked expiration date stamp on the device (where applicable)

Types of VDS vary by emergency situation. VDS are classified as either pyrotechnic or non-pyrotechnic.

NOTE — Some pyrotechnics may be restricted on certain bodies of water. Check with local authorities, or visit the National Association of State Boating Law Administrators (NASBLA) website: <http://www.nasbla.org> or the U.S. Coast Guard website: <http://www.uscg.mil> for additional information.

See the *U.S. Coast Guard Minimum Onboard Personal Safety Equipment Required* section of this manual for specific onboard requirements.

AUDIBLE SIGNALING DEVICES

Audible (sound) signals are required to be on board all boats to alert other boats of your presence or intentions. A boat less than 39.4 feet (12 meters) must always have an efficient sound-producing device on board (Example: hand or mouth whistle, or a compressed or powered air horn).

A boat at least 39.4 feet (12 meters) but less than 65.6 feet (20 meters) operating in inland waterways must always have a power whistle or powered air horn and a bell on board.

All devices must be acceptable for use in marine environments, audible for 1/2 nautical mile and maintain a continuous four- to six-second sound duration. The diameter of the bell's mouth must be a minimum of 7.9 inches (20.0 centimeters).

Ensure all passengers understand how to operate all audible distress signaling devices on board. Keep these devices in a readily accessible area and within immediate reach at all times when boating.

See the *U.S. Coast Guard Minimum Onboard Personal Safety Equipment Required* section of this manual for specific onboard requirements and see the *Navigational Lights and Night Operation* section of this manual for usage information.



NAVIGATIONAL LIGHTS

Navigational lights are intended to alert other boats to your presence and course and their use is essential to boating safety and the prevention of collisions.

Knowledge of navigation lights is necessary for the boat operator. Regulations require that navigational lights be clearly lit and properly displayed at all times between sunset and sunrise, and always when operating in reduced visibility. The placement, shape and visibility requirements of navigational lights vary depending on boat size, type, activity and the body of water. Do not allow passengers, gear or stowed items to block navigation lights. Check with local authorities, or visit the NASBLA or U.S. Coast Guard website for additional information.

If the boat is equipped with bow and/or stern pole style plug-in lights, be sure to orient the pole properly in the receptacle and lock in place. The white light is for the stern and the combination red/green light is for the bow, center. If using separate bow lights, the red light is for the front left (port), and the green light is for the front right (starboard). After inserting, check for proper operation of the lights.

For additional information, see the *Navigational Lights and Night Operation* section of this manual.

Show Lighting

The navigational lighting required by the USCG from sunset to sunrise and in inclement weather is extremely important to boat navigation. The lighting rules are not only designed to indicate direction and right-of-way, but are also designed to prevent night blindness and confusion with navigational aid, emergency and shore-based lights.

The arrival of inexpensive LED lights and red/green/blue (RGB) controllers suitable for “show” use has become extremely popular with boaters. Installing supplemental lighting for “show” can be very dangerous, confusing and distracting to other boaters, and may be illegal. The operator is responsible for complying with local laws and must be familiar with local marine lighting regulations that are constantly evolving before use. Keep these points in mind for show lighting:

- Do Not install lighting outside of the boat above the waterline.
- Do Not install lighting inside the boat above the gunnels where the light source can be seen directly from outside the boat.
- Use caution when changing RGB light color, as some light colors may not be compliant with certain local ordinances; blue lighting is typically reserved for law enforcement use only.
- Be sure to switch off show lighting and lighted accessories such as speakers (not navigation lights) when underway. Most states allow the use of underwater lighting while underway.
- Use only factory-installed, low-intensity courtesy lighting or “mood” lighting when underway.

NOTICE

Never use onboard accessory equipment containing LED lighting when underway.

RECOMMENDED SAFETY EQUIPMENT

Carry and know how to use the following equipment in addition to the required equipment on board at all times as an extra safety precaution:

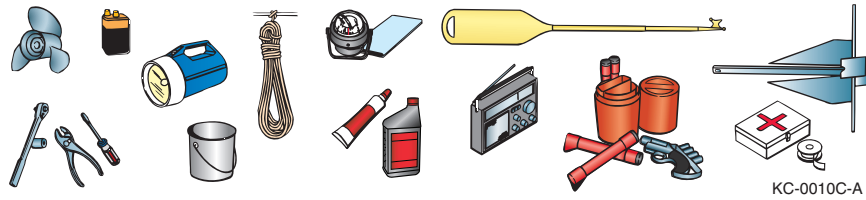

Anchor and line with minimum 75 feet (23 meters) of line	GPS Global Positioning Device
Auxiliary starting battery	Insect repellent
Binoculars	Local charts and compass
Boat hook	Mirror, whistle and strobe light
Cellular phone with waterproof case and lanyard	Mooring lines
Compass	Navigational and interior light bulbs
Dock fenders	Oar/paddles
Dry bag	Propeller, nut and washer
Duct and electrical tape	Radio
Electrical wire	Sharp folding pocket knife
Emergency food and water	Solar USB charger and cable
Emergency Position Indicating Radio Beacon (EPIRB)	Spark plugs
Engine lubricant	Sunglasses and sun block
Extra drain plug	Thermal clothing
Extra transom plug	Throwable life ring
First aid kit and manual	Tool kit including propeller replacement tools
Flashlight and radio batteries	Tow line
Foul weather gear/clothing	VHF-FM/AM with weather band radio
Fuses	Waterproof flashlight



VERY HIGH FREQUENCY (VHF) RADIO

The VHF radio is used to communicate with others on and off the water. VHF channel 16 (156.8 MHz) is designated as the international distress, safety and calling channel and is used to summon rescue services such as the USCG and to make initial contact with ports, marinas, bridges, locks and other boaters in the area. Use a VHF radio. The best way to clearly understand and deal with crossing, overtaking and meeting situations in open water is to communicate with the other boat on the radio.

The responder may then ask the caller for other information to help the caller. It is important to remain calm, speak slowly and be succinct. Short and concise communications are best no matter what the situation is.

Since VHF radios have limited distance line-of-sight (to the horizon) capabilities, it is important for all boaters receiving the distress call to attempt to render assistance until the rescue authorities arrive. The very nature of open water escalates the importance of any distress call. Boaters should always monitor (listening watch) channel 16 but never use it for casual communications. Assist others in distress if possible or monitor the situation until help has arrived.

In other communications, call the other party on channel 16 using your call sign. Bridges and locks will instruct boaters on what to do. Harbors, marinas and other boaters in the area will inform boaters to switch to a particular channel. Most VHF radios transmit in “simplex,” where communication can only take place in one direction at a time. For this reason, standard etiquette is to never interrupt a transmission and to wait 15-30 seconds before making a transmission. There are many channel options available for both commercial and non-commercial use.

NOTICE

The USCG is the lead agency for maritime search and rescue (SAR) in U.S. waters, but that mission is compromised every time the service receives a hoax distress call. Making a false distress call is a violation of federal law (14 U.S. Code § 88) and may result in up to six years in prison, a \$250,000 criminal fine, a \$5,000 civil fine, and reimbursing the U.S. Coast Guard for the cost of performing the search.

Using a VHF radio in foreign waters with a U.S.-registered boat may require a federal Ship Station License by law or treaty. Traveling to a foreign port (for example, Canada, Bahamas, British Virgin Islands and Mexico) requires a Ship Station License as well as a restricted radiotelephone operator permit (RR). Go to www.fcc.gov/wireless/bureau-divisions/mobility-division/ship-radio-stations for more information.

Read the VHF manufacturer’s information on the special features and use of the radio.

PERSONAL LOCATION BEACON (PLB)

While an EPIRB is registered to the vessel, a PLB is registered to the user. Similar to an EPIRB, PLBs must be registered in the National Oceanic and Atmospheric Administration (NOAA) Search And Rescue Satellite Aided Tracking (SARSAT) database with personal information that is required to be updated every two years and reported if the unit is sold. Handheld waterproof marine PLBs also have long-lasting batteries stamped with an expiration date. Since the PLB identifies the user, it can also be used on land when hiking or for other remote activities.

SITUATIONAL AWARENESS

A good captain knows that it is important to continuously observe the surroundings and traffic when operating. Good captains also use their eyes to track things around the boat and their ears to hear engine and mechanical issues. Technology should only be used to supplement the conditions and events happening around you and is not meant to replace situational awareness. While available technology and automation help captains see the big picture, the captain is responsible for knowing what is going on around the boat. If possible, post a lookout or lookouts when underway.

Do not get immersed in the boat’s technology or blindly follow GPS routes without keeping watch or consulting depth charts. Study the manuals for each piece of equipment and monitor the information for the task at hand, be it depth, traffic, infrared camera, engine data, course or weather.

DRIVING DEFENSIVELY

Sharing boats is becoming more popular in the boating culture. Boating has seen an influx of new, inexperienced and untrained boaters due to peer-to-peer boat-sharing apps and boat clubs. It is increasingly probable that someone on the water “tried” boating because it looked fun. Many of the boat owners sharing their boats do little more than cover safety equipment, starting, stopping and docking instructions. With shares lasting half a day or less, there is little time for much training, let alone covering the rules of the road and navigation.

Boat-sharing is in a legal gray area and is not clearly defined in maritime law. Enforcement of existing rules is nearly impossible and almost always after-the-fact. Operators should assume that the other boat operator is untrained and should drive defensively. Boaters choosing to share their boat should discuss the issue with their insurance agent first and consider a mandatory captain requirement. Use only reputable sharing services and frequently check for new or updated USCG and state requirements.

SMALL BOATS AND SWIMMERS

Canoes, kayaks, paddleboards and swimming inflatables have become impulse purchases for many, as they appear fun to use and prices have fallen. Most of these operators are new to the sport and have no training on rules of the road or navigation. This is further complicated by the low, thin profile that makes these small boats difficult to see, especially in the sun, glare and rough water. Operators should keep a close lookout for these boats, swimmers and other boats. Assume that the person is untrained and give them plenty of space.

KNOWING THE BOAT

Be thoroughly familiar with onboard systems and other equipment, especially the critical systems and equipment such as throttle and shift controls, steering, backup steering, running lights, fuel filters, sea strainers, and all emergency safety equipment. Should an emergency arise, the captain will need to act safely and efficiently.

SPECIAL NEEDS PASSENGERS

Keep these special precautions in mind when enjoying a day on the water with passengers who have special needs.

Toddlers

- Never leave children in the boat without adult supervision.
- Must weigh at least 18 pounds (8.2 kilograms), since that is the smallest children’s life jacket approved by the USCG. Life jacket must be worn whenever near the water.
- Any device the child is placed in must have flotation.
- Child-proof the boat just like a home. Be sure all gates and compartments are closed and latched.
- Keep a close watch on the child’s reaction to speed and conditions and react accordingly.
- Use a higher than normal SPF waterproof sunscreen and re-apply more often than usual.
- Find a safe area to put the child down without risk of going overboard. Allow the child to get accustomed to the surroundings before launching/leaving.
- Keep trips short, but let them have some fun if possible.

Pregnant Women

- Go boating during the day and in calm seas.
- Avoid sharp turns and slow down for large wakes.
- Drink more water than usual to stay hydrated.
- It is a good idea to stay seated in the accommodation deck area while underway.
- Stay close to the home port in the third trimester.

People with Handicaps and Elderly People

Depending on the disability, there are many marine-specialized options available to make boats safer and friendlier. Researching on the internet for your specific needs is the best way to start.



Pets

- Not all pets can swim; consider a life jacket.
- If playing fetch in the water, get a pet-friendly boarding ramp to make re-boarding easier.
- Provide a shaded area and plenty of fresh drinking water.
- Consider foot protection for hot sand and boat surfaces.
- Allow the pet to get accustomed to the surroundings before launching/leaving. Keep the first outing short to allow the pet to get used to the boating environment.

CRUISING LIMITATIONS

- Scan constantly for people, objects and other watercraft. Be alert for conditions that limit your visibility or block your vision of others.
- Operate defensively at safe speeds and keep a safe distance from people, objects and other watercraft.
- Do not follow directly behind other watercraft.
- Do not go near others to spray or splash them with water.
- Avoid sharp turns or other maneuvers that make it hard for others to avoid you or understand where you are going.
- Avoid areas with submerged objects or shallow water.
- Operate within your limits and avoid aggressive maneuvers to reduce the risk of loss of control, ejection and collision.
- This is a sophisticated boat—not a toy. Sharp turns or jumping waves or wakes can increase the risk of back/spinal injury (paralysis), facial injuries, broken legs, ankles and other bones. Do not jump waves or wakes.
- Do not operate the boat in rough water, bad weather or when visibility is poor; this may lead to an accident causing injury or death. Be alert to the possibility of bad weather. Take note of weather forecasts and the prevailing weather conditions before setting out in the boat.
- Leave a “float plan” with a responsible person on shore. Tell where you plan to go and when you plan to arrive, and provide a description of your boat. Advise this person if your plans change and also when you arrive to prevent false alarms. Refer to *Float Plan* in this manual for additional information.

HAZARD INFORMATION

- Never start the engine or let it run for any length of time in an enclosed area. Exhaust fumes contain carbon monoxide, a colorless, odorless gas that may cause death within a short time. Always operate the boat in an open area.
- Do not use the reverse function to slow down or stop the boat, as it could cause you to lose control, be ejected or impact the steering wheel or other parts of the boat. This could increase the risk of serious injury. It could also damage the shift mechanism.
- Reverse can be used to slow down or stop during slow speed maneuvering, such as when docking. Once the engine is idling, shift to REVERSE and gradually increase engine speed. Make sure that there are no obstacles or people behind you before shifting into REVERSE.
- Stop the engine and remove the clip from the engine cut-off switch before removing any debris or weeds that may have collected around the propeller.

WATER SPORTS

 **WARNING** *Control Hazard: It is unlawful to participate in water sports while under the influence of alcohol or other drugs.*

Some boats are not designed or recommended to be used for water sports. For recreational boats, water sports include any activity performed in the water such as waterskiing, kneeboarding, wakeboarding, wakesurfing, hydrofoiling, swimming, diving, snorkeling or gliding using a device that may be pulled by a boat. Boats equipped with a ski pylon, tower or hard top tow point, or a transom-mounted ski tow eye can be used for most water sports in accordance with the capacity limits listed on the label.

*Inflatables, also known as tubes, have some unique safety considerations and require the use of both stern eye strong points in combination with a proper tube harness and tow rope; see *Inflatables/Tube Tips* in this section for more information. Parasails and kites require specialized equipment and training and should never be used with a recreational boat.*

Check with local and state authorities or water sports clubs and affiliations for additional information.



NOTICE

The tow points are only approved for towing water sports accessories.



PLATFORM DRAGGING

These dangerous and even fatal activities can lead to any or all of the following, as well as other dangers not listed here:

- Carbon monoxide poisoning
- Severe injury from a rotating propeller
- Drowning or entrapment under the water

NOTICE

It is **UNLAWFUL** to be on or holding on to the boarding platform, swim deck, swim step, swim ladder or any portion of the exterior of the transom at any time while the boat is running or underway in any direction and at any speed.

⚠ WARNING *Personal Injury Hazard: Body, teak or platform dragging is extremely dangerous and can be fatal. Never hold on to the transom of a boat while in the water when the boat is running or underway.*

- **Do not use the boarding platform or ladder for any purpose other than boarding the boat or entering the water.**
- **Do not use the boarding platform or ladder while the engine is running.**
- **Do not swim under the boarding platform when the engine is running.**

WATER SPORTS GUIDELINES

Boat Operator, Occupants and Participants

The following water sports guidelines only cover the general conditions that frequently arise. The participants must respond to the constantly changing weather and the conditions of the sea by using reasonable and safe judgment in light of the circumstances.

- Always ensure that all water sports participants and occupants of the boat, especially the operator, are fully aware at all times of the participants' condition and location in the water, as well as the surrounding environment.
- Make safety the primary concern of all involved during the activity. Only allow safe and capable participants to engage in the activity.
- The boat operator and water sports participants must always know their limitations in the activity and never exceed them.
- Never perform water sports in or near:
 - Congested areas
 - Restricted areas
 - Navigation or other waterway markers
 - Other boats
 - Other water sports participants
 - Obstructions in the water
 - Shorelines
 - Shallow water
 - Hazardous weather conditions
 - Hazardous waterways, rapid moving water, dams, spillways, etc.
 - Areas or times of restricted visibility
 - Hours between sunset and sunrise
 - Locations too far from shore that could hinder immediate rescue or emergency help if needed
- Always engage in water sports activities in safe waterways only.
- Always attach the water sports tow rope to approved attachment points on the boat.
- Never jump from a boat that is moving at any speed, and do not enter or exit the water when the engine is running.
- Never use different length ropes simultaneously for water sports activities.



- Always make sure that participants know and use approved skiing hand signals and common skiing courtesies.
- Before starting, always agree to speed and communication hand signals between the boat operator, spotter/observer and participants.
- Before starting, always inspect the water sports equipment and tow eye, tow point and tow line for safe operating condition, or damage that may lead to failure.

Know Water Sports Hand Signals



Boat Operator Specific Guidelines

The following guidelines are for the boat operator while a participant is in the water.

- Always have a “spotter” (designated observer) other than the boat operator on board to ensure the safety of the participants in the water and provide communication to and from the boat operator and the participants.
- Always turn the engine off from a safe distance when approaching participants in the water and allow them to reach the boat. Never run the engine near a person in the water.
- Never operate the boat in reverse to retrieve anyone in the water.
- Always return immediately to a fallen water sports participant. Always approach the participant on the operator’s side while keeping the participant in view from a direction opposite the wind or seas.
- Never drive directly at a person in the water or directly behind another boat.
- Always maintain a safe distance from people and objects in and on the water.
- Always look in the direction you plan to turn before turning the boat to pick up a fallen skier.
- Never retrieve any object from the water while the engine is running.
- Always keep the skier in view when the skier is entering or exiting the boat.
- Always watch the skier as the line begins to tighten (in case the rope wraps around ski or skier).
- Always look ahead before starting.
- Always start from a safe place with good forward and peripheral visibility.
- Always check direction of steering before starting, ensuring that the boat steers straight.
- Always be aware of what is occurring in front of the boat, and of a participant’s condition.
- Always display a “skier down” flag whenever a skier is in the water and not skiing.
- Always follow the approved towing pattern for the waterway in which you are operating.



Additional Guidelines for Participants in the Water

The following guidelines are for the water sports participant.

- Never participate in water sports if you cannot swim.
- Always wear a bright-colored USCG-approved activity life jacket at all times. Wear suitable protective clothing or gear and/or a wet suit to prevent impact injuries, abrasions and hypothermia.
- Never approach or enter the boat if the engine is running.
- Always avoid the boat's propeller. Even when the propeller is not rotating, its sharp edges can cause serious injury.
- Never put any part of your body through the handle of the ski line or wrap the line around any part of your body.
- Never enter the water from a boat that is running or moving at any speed.
- Always indicate that you are clear of the boat prior to the operator starting the boat or putting the boat into gear and tightening the rope.

Inflatables/Tube Tips

Today's market offers various types, shapes and sizes of towed inflatables (known as "tubes" or "inflatables"). A person can ride "in" or "on" (depending on the style) these inflatables while out on the water. Regardless of the type, they all produce tremendous stress on the tow point and rope, far greater than devices like water skis, kneeboards or wakeboards. When using tubes, keep the following points in mind:

- Follow the general water sports safety guidelines in this section for operating the engine, using life jackets, using a spotter, guarding against rope entanglement, reviewing equipment condition before use, understanding rider skill levels, and abiding by regulations for distances to other boats, docks and shorelines.
- Do Not exceed a towing speed greater than 8 mph (11km/h) for small children, 15 mph (24 km/h) for children up to 18 years old, or 20 mph (32 km/h) for adults.

- Do Not attempt to intentionally cause a tube rider to fall and use extreme caution with multiple riders to prevent slamming riders together.
- Do Not use tow ropes shorter than 50 ft (15 m), or longer than 65 ft (20 m). Be sure the tow rope and tube is rated for the combined weight of all riders and uses the proper attachment points. A braided tow rope offers a degree of stretch to minimize shock to the rider.
- Do Not use ski tow pylons, hard top, tower or ski tow eye points for tubes. Use both port and starboard stern eye strong points with a tube tow harness to attach the tube tow rope. Add a floating ball to the tow rope to keep the rope on top of the water and improve performance. If you do a lot of tubing, invest in a transom-mounted bracket made specifically for towing tubes (see your dealer).
- Check the tube air pressure often and keep at the manufacturer's recommended level as listed on the device. Pressure levels can change rapidly from sun and shade; too low and it creates additional drag, too high and it may cause tube failure.
- Tow only one tube at a time.
- Read and understand the user's manual for the tube; instruct children on the Do's and Don'ts.



CAUTION

Personal Injury/Equipment Damage Hazard: Ski tow pylons/tower/hard top/ski eye tow points are not designed for use with tubes. The added stress of the tube may cause a dangerous recoil or damage the tow point. Damage to the pylons/tower/hard top/ski eye tow points is not covered by the boat or equipment manufacturer's warranty. If towing tubes/inflatables, use both stern eye strong points with a tube tow harness to attach the tube tow rope. Consult the boat manufacturer for stern eye tow limits.

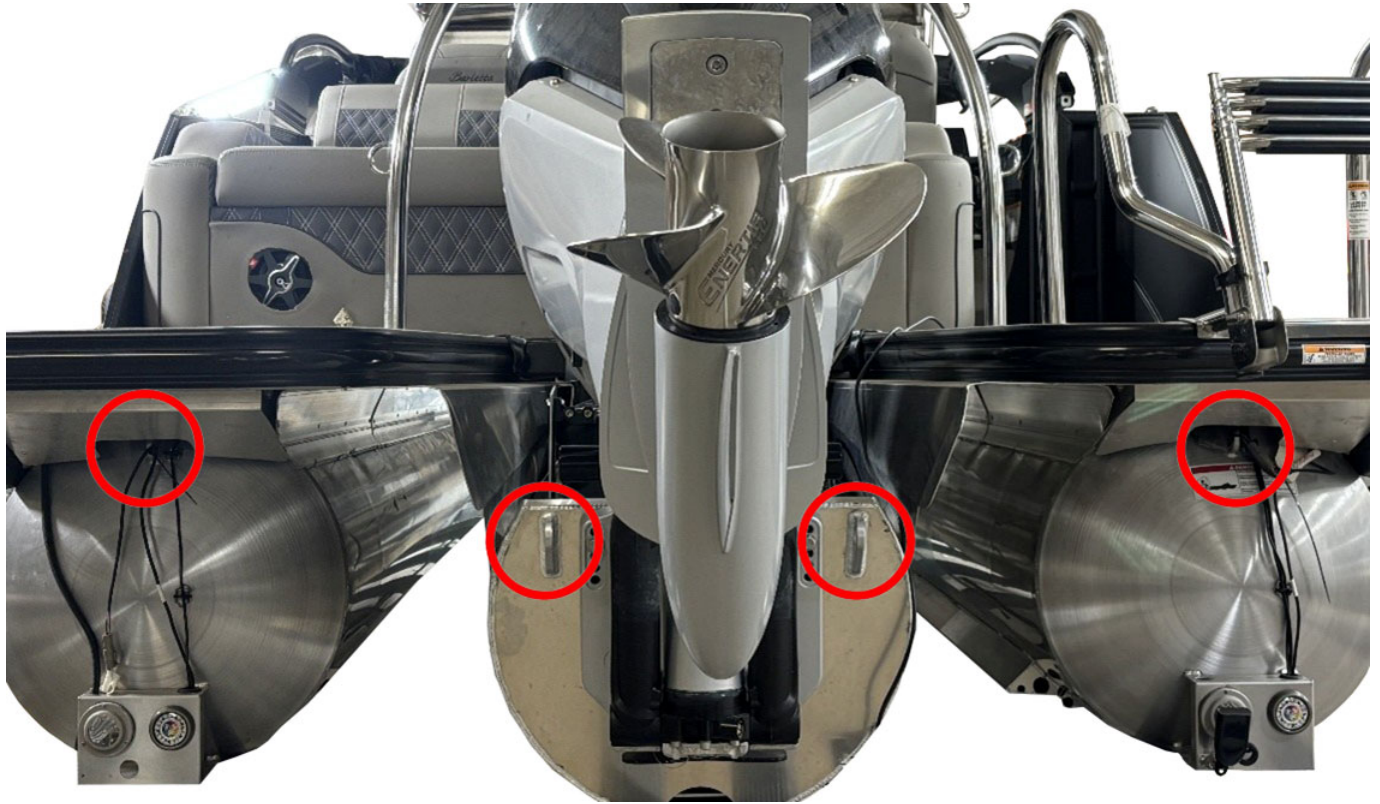

⚠ WARNING *Tow Hazard: Do not use stern eyes as a tow point.*

Using the Platform/Boarding Ladder

⚠ WARNING *Personal Injury Hazard: Always turn the engine off whenever anyone is in the water near the boat.*

To board, carefully deploy and use the boarding ladder if available. You may also pull yourself onto the boarding platform to enter the cockpit of the boat. Boats equipped with a boarding platform have a few extra precautions to be aware of:

- NEVER allow anyone on the boarding platform or in the water near the platform while the engine is running.
- NEVER attempt to surf on or off the platform while the engine is running.
- NEVER “platform drag” or touch the boarding platform from the water while the engine is running.
- NEVER exceed the weight capacity of the boarding platform. All boarding platforms have weight limits. If there is no capacity label, ask the dealer.
- Boarding platforms may be wet and slippery. Advise passengers to use caution and any available handholds when using the platform. Never apply wax to the working deck portion of the platform.
- If the boarding platform is equipped with a ladder, be sure the ladder is fully retracted and secured before operating the boat.
- If the boarding platform is removable, be sure it is properly secured before operating the boat.

Designated Occupant Seating

It is important to use the designated occupant positions (DOP) when underway, if applicable. You must also understand that even though the capacity label identifies the number of passengers for your model, the actual number of passengers is determined by weight. Your boat model may have 10 DOP seats and a capacity label that says 8 persons or 1500 pounds. This means that you may have a maximum of 10 people as long as the sum total weight of all the people and gear does not exceed 1500 pounds. Likewise, it may be possible that the 1500-pound limit *could be exceeded with only 7 people or less.*

For more information on capacity, see *Section 1, Hull Identification, Capacity and Safety Plates*. For more information on seating, see *Section 2, Safety*. For more information on the proper distribution of passengers on the boat, see *Section 7, Boat Loading*.

Water Sports Safety

IMPORTANT

The following water sports safety warnings and practices represent some (but not all) common risks encountered by users. Always use common sense and good judgment.

Before skiers/riders get in the water: Waterskiing or riding instruction is recommended in advance. Instruction will teach general safety guidelines and proper waterskiing or riding techniques, which may reduce their risk of injury. For more information on waterskiing or riding schools, contact the dealer, association or local waterskiing club.

Inspect all equipment prior to each use. Check bindings, fins, tube, attachment, tow rope and flotation device. Do not use if damaged.

Special boat considerations: A knowledgeable and responsible driver along with a separate observer is the most important safety device on any boat.

- Some states have specific regulations for allowable propulsion systems that can be used for tow sports, especially wake surfing. It is the operator's responsibility to know the applicable regulations.
- Never exceed the passenger or weight limitations of the boat.
- Never allow passengers to hang outside the boat or towed device or sit on the gunwales or anywhere outside of the normal seating area.
- Never allow water to overflow the bow or gunwales of the boat.

- Uneven weight distribution or additional weight may affect the handling of the boat.

Tow ropes: Tow ropes come in different lengths and strengths for different activities. Make sure any rope used is suited for that activity and that it is in good condition.

- Never use a rope that is frayed, knotted, unraveling or discolored from use or being left in the sun. If a rope breaks while in use, it can recoil at the skier/rider being towed or into the boat where it might strike passengers. Replace tow ropes with any sign of damage.
- Never use a tow rope with elastic or bungee material to pull skiers or riders.
- Rope should be attached to the boat in an approved fashion with hardware designed for towing. Refer to the boat manual for instructions on proper tow rope attachment.
- Always keep people and tow ropes away from the propeller, even when idling.
- If a tow rope should become entangled in a propeller, shut off the engine, remove the key and secure it in a safe location before retrieving the rope.
- Tow ropes should be neatly stowed in the boat when not in use.

Preparing to ski or ride: Always have a person other than the driver act as an observer to look out for the skier/rider.

- Be sure the driver is aware of the experience and ability level of the skier/rider.
- The driver, observer and skier/rider need to agree on hand signals before skiing or riding. Signals should include READY, STOP, SPEED UP and SLOW DOWN.
- Start the engine only after making sure that no one in the water is near the propeller.
- Turn off the engine when people are getting into or out of the boat, or in the water near the boat.
- Always make sure the tow rope is not wrapped around anyone's hands, arms, legs or other parts of the body.
- Start the boat and move slowly to remove slack until the tow rope is tight.
- When the skier/rider signals READY "hit it" and there is no traffic ahead, take off in a straight line. Adjust the speed according to the signals given by the skier/rider.



Skiing or riding: The boat and skier/rider should always maintain a sufficient distance from obstacles so a skier/rider falling or coasting and/or boat will not encounter any obstacle.

- Do not use in shallow water or near shore, docks, pilings, swimmers, other boat or any other obstacles.
- Use only on water.
- Never attempt land or dock starts or stops. This will increase the risk of injury or death.
- The faster the skier/rider skis or rides, the greater their risk of injury. The skier/rider should be towed at an appropriate speed for his or her ability level.
- Never make sharp turns that may cause a slingshot effect on the skier/rider's speed.

Fallen skier or rider:

Falling during water sports is commonplace and injuries can occur from a variety of causes.

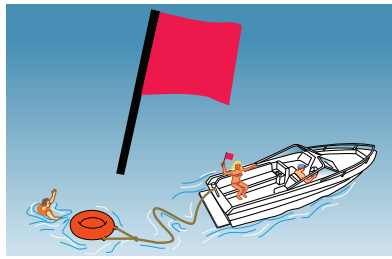

- If the skier/rider does not immediately indicate that they are "OK," assume that they need assistance.
- Circle a fallen skier/rider slowly to return the tow rope handle or, pick up the fallen skier/rider.
- Turn off the engine when near a fallen skier/rider.
- Always keep the fallen skier/rider in view and on the driver's side of the boat.
- Display a red or orange "skier down" flag to alert other boats that a skier/rider is down if required by the state in which you are operating.

Water Sports and Towing Safety

Boat operators, skiers and boarders must all be aware of current boating and water sports rules and pay attention to safe operating procedures and skiing practices at all times. If skiing or boarding is a new sport to you, seek certified training before starting. Thoroughly read all information provided by the water sports equipment manufacturer.

Always remember that the majority of water sports injuries are the result of impacts with other objects. Know the area you are boating in.

Always maintain a clear vision of where you are going and be aware of what is going on around you. Constant vigilance will go a long way toward preventing accidents. Skiers, boarders and other water sports participants must always wear a USCG-approved life jacket. It's the law!

Contact with rotating propellers is one of the most dangerous hazards that occurs from negligence of operators, passengers and bystanders. A propeller is designed to travel in the water and rotates at a speed that can cause death if it comes into contact with a human. Severing, deep lacerations, blood loss, trauma and exposure to microorganisms in the water that enter the bloodstream can result in death or serious injury.

STOP PROPELLER STRIKES by always using caution and:

- OBSERVING all warnings and keeping all safety equipment in use and in place.
- STOPPING the engine when swimmers are near the boat and in the water.
- MAKING SURE all passengers are seated on a horizontal seat cushion whenever the boat is in gear or moving.
- NOT ALLOWING passengers to enter the water when the engine is running.
- USING the boat's engine cut-off switch and link at all times.
- MAKING SURE all operators are properly trained and qualified to operate the boat.
- KEEPING your eyes on your path as well as the water sports participant.
- NOT ALLOWING water sports participants to be in the path of other boaters.
- STAYING CLEAR of swimmers and other water sports participants by maintaining visual surveillance.
- KNOWING the correct water sports hand signals.
- NOT ALLOWING children under 11 years of age to occupy the open bow area unless accompanied by an adult.
- USING an observer during water sports activities.



Water Sports Responsibility Code

BE AWARE there are risks in boating and water sports that good judgment and personal awareness can help reduce. To increase enjoyment of water sports, follow the 10 points of the code.

In water sports, it is the boater's responsibility to:

- ALWAYS become familiar with applicable laws, waterways and inherent risks.
- ALWAYS have a capable observer in addition to the driver, and use agreed-on hand signals.
- ALWAYS wear a properly fitted life jacket approved by your country's agency.
- ALWAYS read the user's manual and inspect equipment before use.
- ALWAYS ski and ride under control, at proper speeds and within your limits.
- ALWAYS turn the ignition off when anyone is near the boat power drive unit.
- ALWAYS stay clear of engine exhaust to avoid carbon monoxide poisoning.
- NEVER "platform drag" or touch boarding platform while the engine is running.
- NEVER ski or ride near swimmers, shallow water, other boats or obstacles.
- NEVER operate boat and never ski or ride under the influence of alcohol.

Driver: Best Practices

- The boat driver plays a critical role in the enjoyment and safety of all towed water sports participants. Do not allow inexperienced drivers to drive for skiers/riders without thorough instruction and training. We encourage all boat operators to take a boater's education course. See the state's boating authority for available courses or other operating requirements.
- Keep music at reasonable levels. Sound travels well over water.
- Wait for a clear boat path ahead before accelerating.
- Make sure to use the proper rope for the sport. A rope designed to pull a skier is not the recommended rope for towing a tube.

- If skiing, boarding or tubing with more than one person, make sure all tow ropes are the same length.
- Keep a 150-foot buffer zone on all sides of the boat and stay in water that is safe for the skier/ rider and draft of the boat.
- Make sure the tow line unwinds smoothly without getting snagged on anyone or anything.
- Idle forward to make the rope tight.
- Accelerate only when the tow rope is completely tight and the skier/rider has given the "hit it" signal. The words GO and NO can be easily confused with nearby wind, water and engine noise. It is best to find another signal other than GO to tell the driver to power up. "Hit it" or "boat driver" are better options.
- Always approach fallen skiers/riders in the water from the driver's side so the driver does not lose sight of them.
- Minimize repetitive passes on any one portion of shoreline. Once you've run the same line for a while, move on to another area.

TURN OFF ENGINE when a skier/rider is near the boat, rather than running the engine in NEUTRAL. An accidental bump of the throttle when the engine is running could put the boat in gear.

- DO NOT let the tow rope slip under the boat and become tangled in the propeller. It is a good practice to keep a knife on board should this situation occur.
- Always pay attention to the water ahead, the surrounding traffic and the onboard observer. The observer must always keep the boater aware of the skier/rider status.
- DO NOT whip skiers or riders near shores, docks, other boats or fixed obstructions; they can glide 100 feet or more after they let go of the rope.



WARNING *Entanglement Hazard: Never accelerate before the rope is 100% tight and before the skier/rider gives the "hit it" signal. Accelerating before the "hit it" signal is given could result in the skier/rider becoming entangled in the rope.*



Driving Pattern

Check with local lake laws before driving any pattern. Some areas require operators to drive skiers/riders in preset patterns.

Operators who want to minimize the rough water for the skier/rider should use a dog-bone pattern when driving. A dog-bone pattern follows the same path from one end of the course to the other, with tight controlled turns at each end. Use this pattern where few other boats are operating.

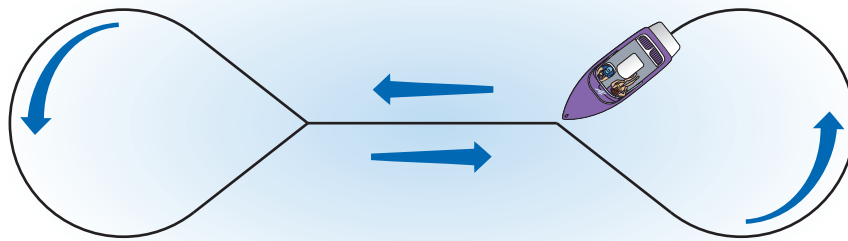

KC-0317C-A

In areas where many boats are operating, use a large racetrack pattern.

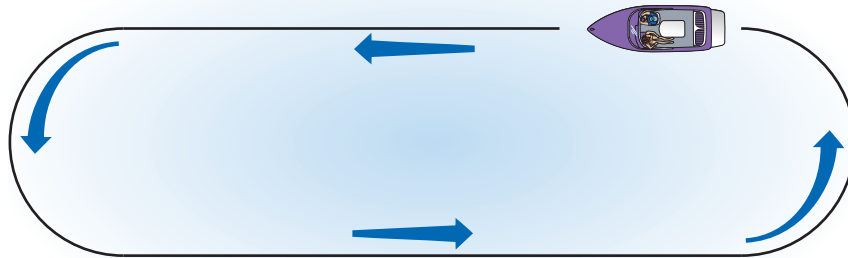

KC-0358



Falling Tips for Every Sport

- Sudden falls happen. DO NOT put any body parts (arms, legs, head) inside the rope handle.
- Tighten the life jacket straps for a snug fit.
- Let the handle go as soon as you sense you're about to fall. Falling is better than dragging.
- Roll with it. Bow your head, bend your knees, tuck in your arms and make like a beach ball.
- Signal the observer to let them know you are OK after a fall.
- After you fall, lift the ski or board above the water so other boaters can see you.
- When learning advanced maneuvers, it's best to seek training from a professional.
- A little advice will cut down on falls, shorten the learning time and reduce the chances of an injury.

Water Sports Tips

These tips are designed to help speed learning while ensuring safety. Practice, training from a professional and advice from experienced boaters are the best tools for learning safety when it comes to water sports.

For additional information visit: www.teamusa.org/USA-Water-Ski

REMEMBER: It is important to follow the manufacturer's recommendations for the intended use of the water sports equipment.

REMEMBER: It is illegal in many states to participate in towed water sports without a USCG-approved life jacket. Be aware that some specialized water sports vests are NOT USCG-approved and should be worn in addition to a USCG-approved life jacket.

BE AWARE: The boater is responsible for their own wakes. Be considerate of other boaters, especially small fishing boats, canoes, kayaks, paddleboards and other low-profile boats that can overturn easily. Also, be aware of your wakes in relation to swimmers, docks and boats tied to docks.

Section 3

BOATING REGULATIONS AND YOUR RESPONSIBILITIES

The U.S. Coast Guard (USCG) is the federal authority on U.S. coastal and inland waterways, but state and local regulations may exist that exceed USCG regulations. The purpose of all these regulations is to assist the boating public and maintain navigational order on waterways.

Many state equipment requirements go beyond USCG requirements. Contact state and local boating authorities for further information. Equipment requirements for coastal and inland waters differ. Check with local authorities or the USCG for further information about coastal water requirements.

Boating regulations are enforced by USCG, state and local authorities. Operators/owners are subject to marine navigation regulations for both federal and state waterways. Operators/owners must comply if enforcement officers signal them to stop the boat or if they ask to board the boat.

Many USCG, state and local resources are available. For additional and current information on regulations, safety and navigation, contact the local USCG unit or local marine authority.

See the *References and Contact Information* section of this manual for a list of resources.

BOAT OWNER / OPERATOR RESPONSIBILITIES

As a boat owner/operator, understand and be aware of USCG federal regulations as well as state and local regulations where operating the boat. Boating regulations include, but are not limited to, boat regulations, boat equipment regulations and navigational regulations.

Operators/owners must have on board at all times all mandatory safety and boat equipment as regulated by the governing authorities. All equipment must be maintained in proper working order.

SAFETY

Boat owners/operators are legally responsible for their safety, the safety of their passengers and the safety of other boaters. In addition, they are responsible for the operation and navigation of the boat under all operating conditions. The boat must be in compliance with USCG safety equipment regulations.

REGISTRATION

The USCG requires that all power boats operated on the navigable waters of the United States be currently registered in the state in which they are principally used. Many states require current registration in that state whenever boating on waters within their state boundary. Always contact state boating authorities (and authorities in neighboring states) for registration information on boats and trailers.

Registration numbers must be current and clearly displayed on the boat according to the defined regulations. Registration certificates must be current and on board at all times.

State and local authorities may require additional registration for boating on certain waterways. Check with state and local authorities for additional registration information.

For more information visit:

- U.S. Coast Guard Office of Boating Safety:
<http://www.uscgboating.org>
- National Association of State Boating Law Administrators:
<http://www.nasbla.org>

INSURANCE

Boat owners are legally responsible for any damage or injury caused when they operate the boat when an accident or collision occurs. They are also legally responsible even when someone else operates the boat and causes damage or injury. Individual states have laws detailing minimum insurance needs. Contact the insurance agent to verify the type of insurance needed BEFORE operating the new boat.

REPORTING ACCIDENTS

The USCG requires the owner/operator of a boat involved in an accident to report the incident to the proper marine law enforcement agency for the state in which the accident occurred. If a person dies or disappears as a result of a recreational boating accident, the boat owner/operator must immediately notify the nearest state boating authority. If a person dies or has injuries requiring more than first aid, the owner/operator must file a formal report within 48 hours of the accident. An owner/operator has 10 days to file a formal report for accidents exceeding \$500 in property damage or complete loss of the boat. Go to <http://uscgboating.org/recreational-boaters/>, Accident Reporting, for information and form download.

BOATING UNDER THE INFLUENCE



KCB-0011

Federal and state laws prohibit the operation of a boat while under the influence of alcohol or drugs, and authorities actively enforce these regulations. If the operator's blood alcohol content is at or above the legal limit, violators are subject to civil and

criminal penalties and imprisonment. Operating a boat under the influence can also result in a loss of motor vehicle driving privileges.

Alcohol and drugs slow reaction time and affect judgment. This type of impaired operation may result in death or severe personal injury.

Owners/operators are responsible for their passengers, including alcohol and drug use and onboard behavior.

Regulations and penalties for operators and passengers may vary from state to state. Contact local and state boating authorities for specific information.

OPERATOR'S LICENSE AND EDUCATION

This manual does not provide complete training on all aspects of boating safety, operation or regulations. Boating authorities highly recommend that all boat operators and passengers seek additional training in boating safety and seamanship from a USCG-approved course.

Licensing requirements can vary widely from state to state. Most states require operators under the age of 18 to be licensed; however, some states require all operators to be licensed and have the license on the

boat during operation. Some states require boat operators to complete a boating education/safety course to obtain a safety certificate before licensure. Pay special attention if you will be operating on boundary waters shared by two or more states, as the requirements may change once you cross the boundary.

Check with state and local authorities for requirements of an operator's license, certificate or training before you or anyone operates the boat.

See the *References and Contact Information* section of this manual for a list of some of the agencies and organizations that offer water/boating safety courses, first aid/CPR, or other recommended training and/or information.

OPERATION BY MINORS

Minors must always be supervised by an adult whenever operating a boat. Many states have laws regarding the minimum age and licensing requirements of minors. Regulations may vary from state to state. Contact local and state boating authorities for specific information.

EMERGENCY ASSISTANCE

An operator seeing a distress signal or suspecting a boat is in trouble must assume it is a real emergency and render assistance immediately as long as it can be done safely.

In accordance with Federal law, in U.S. waters, the operator must render assistance to any individual found at sea in danger of being lost, so far as the operator can do so without serious danger to the operator's vessel or individuals on board. An operator who fails to render such assistance can be fined not more than \$1,000, imprisoned for not more than 2 years, or both. The 1971 Boating Safety Act grants protection to a "Good Samaritan" boater providing good faith assistance, and absolves the boater from any civil liability arising from such assistance.

Under general maritime law in international waters on the other hand, if the operator undertakes to perform acts to rescue or aid those in distress, the operator is subject to liability for reckless or wanton conduct or, for failure to exercise reasonable care (negligence) if he worsens the position of the victim.

NOTICE

The operator in charge of the boat is obligated to provide assistance to any individual in danger if such assistance can be provided safely. Carefully assess the situation at hand and assist if possible. If the operator does not possess the skills to safely assist another boat in trouble with the highest degree of care, call for help and stay in the area until help arrives.

NEGLIGENT OPERATION

Federal law prohibits the negligent or grossly negligent operation of a boat and/or interference with the safe operation of a boat so as to endanger lives and/or property. Some actions that may constitute grossly negligent operation (criminal offense) are:

- Operating a boat in a designated swimming area
- Excessive speed in the vicinity of other boats or in regulated waters
- Hazardous waterskiing or other water sports practices
- Bow riding, or riding on a seat back, gunwale, boarding platform or transom
- Operating a boat while under the influence or alcohol or drugs (severe penalties may be imposed for boating under the influence [BUI])

Other actions that constitute negligent operation, such as, but not limited to:

- Failure to use handhold
- Overloading or improper loading
- Using a boat in weather or sea conditions beyond the intended design of the boat or beyond the skill or experience of the operator
- Continued operation with operator's visibility blocked or impaired
- Modification to boat causing an unsafe operating condition

RESTRICTED AREAS**Security Zones**

Operators must avoid all waterways and areas that are restricted, such as military installations, power plants and petroleum and chemical facilities. Because of the threat of terrorism, the U.S. Coast Guard has implemented and will continue to enforce strict limits on boats near U.S. Navy and U.S. Coast Guard ships and other potential targets.

Naval Vessel Protection Zones

Do not approach within 100 yards of any U.S. Naval vessel. Slow to minimum speed within 500 yards of any U.S. Naval vessel. Operators needing to approach within 100 yards to ensure a safe passage in accordance with the Navigation Rules must contact the U.S. Naval vessel or the U.S. Coast Guard escort vessel on the boat's VHF radio (channel 16) for authorization.

Commercial Shipping Safety Zones

Do not operate the boat near cruise liners or certain waterfront commercial installations such as ferry terminals. Observe and avoid all security zones and commercial port operations.

Bridges and Shipping Channels

Do not stop or anchor beneath bridges or in shipping channels. Operators doing so should expect to be asked to move and/or be boarded by law enforcement officials. Anchoring in these areas is dangerous for the operator and others on the water.

AMERICA'S WATERWAY WATCH

Boat operators can help the U.S. Coast Guard in keeping waterways and coastal installations safe and secure. Boat operators can do this by participating in America's Waterway Watch (AWW). Boaters reporting suspicious activities to AWW should call 877-24WATCH if noticing suspicious activity or behavior on or near the water.

In cases of immediate danger to life or property, call the U.S. Coast Guard on channel 16 VHF-FM or dial 911 for emergencies.

FISHING

Fishing can be very exciting and distracting for the operator when the action gets intense. Operators must always be conscious of the primary responsibility, which is the safe operation of the boat and the safety of passengers and other boats in the area.

Always make sure the helm is properly manned and is never left unattended while trolling. If the boat is equipped with a tower, exercise caution and sound judgment whenever someone is in the tower. Remember, weight in the tower raises the boat's center of gravity and the boat's motion is greatly exaggerated for the person in a tower.

An operator fishing in an area that is crowded with other fishing boats may have difficulty following the rules of the road. This situation can become especially difficult when many boats are trolling. Being courteous and exercising sound judgment is essential. Avoid trying to assert the right-of-way and concentrate on staying clear of other boats. Prevent the boat from becoming entangled in lines and from cutting into lines. Also keep in mind that fishing line wrapped around a propeller shaft can damage seals in the engine lower unit.

There is currently a tremendous drain on our fishing resources. Excessive fishing and hunting, as well as pollution, have strained the fish and game population. Help out by keeping only what you will eat; practice catch-and-release and obey bag limits.

Monofilament Fishing Line

Wildlife can experience harm from becoming entangled in or ingesting monofilament fishing line if it is left in the water or on shore. Line in the water can also endanger swimmers and divers and become tangled in boat propellers, causing damage. It can last for years in water, posing a threat for a long time. Fishing line can remain a problem even if put in the trash, because birds can take it from an open bin and become entangled or it can entangle wildlife at landfills.

Many states and private boating/wildlife organizations sponsor programs to collect used line for recycling into new products. Operators who carry used line or happen upon it while boating can dispose of it in recycling bins located at many marinas, launches, tackle shops and state service centers.

WAKE

Boat owners/operators are responsible for the wake the boat creates. Regulations may vary from state to state. Contact local and state boating authorities for specific information, as owners/operators may be responsible for any damage or injury their wake causes. Always be alert for no-wake zones and be courteous of others while boating. Excessive and unexpected wakes can cause dangerous and even life-threatening situations.

NOISE

Boat owners/operators are responsible for the noise the boat creates. Many state and local boating authorities enforce noise limits that may restrict engine noise, radio volume or even loud talking. Regulations may vary from state to state. Contact local and state boating authorities for specific information.

SPEED

Boat owners/operators are responsible for maintaining the boat under control at a safe speed. Many state and local boating authorities enforce speed limits. Regulations may vary from state to state. Contact local and state boating authorities for specific information.

PROTECTING THE ENVIRONMENT

Our lake, river and ocean resources must be protected to be enjoyed by future generations. Boat owners/operators are responsible for protecting the natural environment and wildlife by keeping waterways clean.

U.S. waters are covered by several water pollution regulations administered by numerous federal and state agencies. Laws vary between local, inland, coastal, ocean and international waters. Laws can be enforced by local and state authorities as well as the USCG. For recreational boats, U.S. Federal Water Pollution Control, Oil Pollution Control and Refuse Acts cover U.S. waters, and the MARPOL treaty covers international waters. In any case, pollution prevention centers around three areas:

- Sewage pollution
- Garbage (solid waste) pollution
- Oil pollution

As a boater, make it a point NOT to dump or discharge ANYTHING into waters and tell passengers to respect this rule. Return all trash after boating and dispose of it properly on shore.

DISCHARGE OF OIL PROHIBITED

The Federal Water Pollution Control Act prohibits the discharge of oil or oily waste into or upon the navigable waters of the United States, or the waters of the contiguous zone, or which may affect natural resources belonging to, or under the exclusive management authority of the United States. If such discharge causes a film or discoloration of the surface of the water, or causes a sludge or emulsion beneath the surface of the water. Violators are subject to substantial civil penalties and/or criminal sanctions including fines and imprisonment.

KC-6020

AQUATIC INVASIVE SPECIES (AIS)



KC-6027

Aquatic Invasive Species (AIS) are plants and animals that occur in waters in which they are not native and whose introduction causes or is likely to cause economic or environmental damage or harm to human health. AIS have a negative impact on the waterway, its native species, and recreational and commercial uses of the waterway. As responsible boaters and citizens, each boat owner should do their part to prevent the spread of these aquatic hitchhikers.



In many cases, it is also required by law. Check local regulations for any waterway where you will boat.

After each boating trip, follow these three simple steps before you leave the water access to stop the spread of AIS: Clean, Drain, and Dry. This is the boater's way to help protect the environment from the damage that AIS can cause.

Clean

- Inspect and remove all aquatic plants, animals, mud, and debris from the boat, engine, trailer, anchor, and any watersports equipment.
- Rinse, scrub or wash, as appropriate, away from storm drains, ditches, or waterways.
- Rinse watercraft, trailer, and equipment with hot water, when possible.
- Flush motor according to owner's manual.

Drain

Completely drain all water from the boat and its compartments, including but not limited to the bilge, wells, lockers, ballast tanks or bags, bait containers, engines, and outdrives.

Dry

Allow the boat to completely dry before visiting any other bodies of water. Water-borne organisms cannot survive long periods of dryness.

NOTE — Some localities may require inspection or decontamination before and/or after launching. Check state and local laws and regulations for requirements prior to traveling to go boating.

PAINTS

Boat owners are responsible for the environmental regulations that may govern the use of antifouling paint. If the boat is kept in water where marine growth is a problem, the use of antifouling paint may reduce the growth rate. Regulations may vary from state to state. Contact local and state boating authorities for specific information.

CLEANING AGENTS

Boat owners are responsible for the environmental regulations that may govern the use of cleaning agents. There are many "green" cleaner choices available for most any material on the boat. If using household cleaners, use them sparingly and never discharge them into waterways. Do not mix cleaners and be sure to use plenty of ventilation in enclosed areas. Avoid using chlorine, solvents and products that contain phosphates, as well as non-biodegradable or petroleum-based products. Regulations may vary from state to state. Contact local and state boating authorities for specific information.

EXHAUST EMISSIONS

Boat owners are responsible for the exhaust emissions from the boat. Increased exhaust (hydrocarbon) emissions, which are regulated by the EPA, pollute the water and air. Contact the dealer and the engine manufacturer for more information. Additional restrictions may apply and vary from state to state. Contact local and state boating authorities for specific information.

This Page Intentionally Left Blank

Section 4

EMERGENCIES

Be prepared to deal with emergencies before they happen. Try to formulate a plan for each type of emergency in advance in order to make decisions quickly and without hesitation. Precious moments lost can mean the difference between losing and saving a life.

Before operating the boat, review *Safety in Section 2*.

FIRST AID / MEDICAL EMERGENCIES

Every second counts toward preventing injury or death in case of a medical emergency. Boaters must have proper training and take necessary preventive measures to properly assist in times of need. Carrying an adequate and current first aid kit is critical in the immediate response and care of someone in need of medical attention. Always have dry blankets readily accessible to help prevent hypothermia. For additional information on medical, first aid and safety training such as CPR, contact your state and local authorities, or visit the Red Cross website:

<http://www.redcross.org>.

EMERGENCY PREPARATION CHECKLIST

In addition to a safety equipment list, have an emergency checklist on board to assist in times of emergency. Use the following topics as a guideline to develop a list of emergency procedures and instructions for the use of visual and audible distress signaling devices, radios, first aid kits and all related information that could assist you or others in the event of an emergency.

USING DISTRESS SIGNALS

Ensure all passengers understand how to operate all onboard visual and audible distress signaling devices and communication equipment. Keep all distress signaling devices and communication



equipment in a readily accessible area and within immediate reach at all times. Seconds count during emergencies. Knowing the proper way to use the distress signaling devices aboard the boat can help save lives.

See the *Markers, Warnings and Advisories* section of this manual for more signaling devices.

If your boat is equipped with a VHF radio, there are three primary distress calls:

- **MAYDAY radio call** – A mayday call is reserved for life-threatening situations, such as fire, severe weather or sinking, where lives are in imminent danger or the boat is in danger of sinking. Start the broadcast clearly and calmly with **“Mayday - Mayday - Mayday.”**
- **PAN-PAN (pahn-pahn) radio call** – A pan-pan call is used for urgent but non-life-threatening situations where there is no immediate danger to lives or the boat, such as a loss of steering control or taking on water of any amount. Start the broadcast clearly and calmly with **“Pan - Pan - Pan.”**
- **Securite (se-cure-ih-tay) call** – A securite call is used for non-life-threatening situations to notify authorities and others in the vicinity of important navigation and weather alert calls. Start the broadcast clearly and calmly with **“Securite - Securite - Securite.”**

In an emergency situation the responder needs to know four important pieces of information:

- The exact nature of the emergency and an assessment of the severity
- Number of people on board
- The location (navigation marker, visual reference or GPS coordinates in open water)
- What the boat looks like (hull and top colors, unique features, flags, etc.)

For additional information on the safe and proper use of distress signaling devices and the safe and proper use of emergency communication equipment, contact state and local authorities. Additional information can be found on the USCG website:

<http://www.uscgboating.org>.



SECTION
4

EMERGENCIES

REQUESTING ASSISTANCE (NON-DISTRESS CALL)

If a boater contacts the USCG on Channel 16 VHF-FM or Channel 70 DSC regarding a non-distress situation, the USCG will offer to contact any assistance provider (commercial or friend) the boater requests or will issue a Marine Assistance Request Broadcast (MARB) if the boater has no preference of service.

FIRE AND EXPLOSION

⚠️ WARNING *Fire/Explosion Hazard: Gasoline is extremely flammable and highly explosive under certain conditions.*

- Do not smoke or allow open flames or sparks nearby when refueling.
- Do not store fuel in any containers or compartments which are not designated for fuel storage.
- Static electricity can be generated while fueling and can cause a fire or explosion. To prevent electrostatic spark when refueling, make sure the nozzle is in contact with the fill pipe at all times.
- Avoid damaging fuel lines and connectors and make sure fuel does not contact hot engine parts.
- Do not confuse the fuel fill deck plate with the water or waste fill plates, if equipped. All deck plates are properly labeled. If fuel is accidentally pumped into any other deck plate, do not attempt to pump it out. Water and waste pumps are not designed to pump fuel and a fire or explosion could result. Contact the dealer to have the fuel professionally removed.
- USCG-approved fire extinguishers are required on all Class I, II and III boats.

A fire or explosion may occur when least expected.

The decision to abandon the boat or stay to fight the fire is difficult and depends on many factors. Formulate a fire plan in advance to make

that decision quickly and without hesitation. Keep in mind the following guidelines:

- Many fires are the result of gasoline and oil accumulating in the bilge, careless fueling practices and electrical problems. In the event of a fire, try to stop the boat and turn off the engine as quickly and safely as possible. Immediately use a fire extinguisher at the base of the flames in a sweeping motion to reduce or extinguish the fire. Ensure that all passengers are safe from immediate danger and are wearing life jackets. If the fire is located in the engine compartment (if equipped), make sure the bilge blower (if equipped) is off and do not open the engine cover.
- Once the fire is extinguished, check for other immediate fire threats and personal injuries and call for assistance immediately.
- If you are unable to easily extinguish the fire, or if the fire is uncontrollable, attempt to get yourself and all passengers off the boat and into the water. If possible, ensure that all passengers are wearing life jackets or have access to one by the time they are in the water. Before leaving the boat, if possible, verify that there is no immediate danger of fuel sitting or burning on the water's surface where you and your passengers will be floating. Immediately swim to a safe position upwind from the boat and use distress signals to get assistance.



KC-0074C-A



MAN OVERBOARD (MOB)

A high percentage of boating fatalities are the result of people falling overboard, many of whom were not wearing life jackets. If someone falls into the water unexpectedly, react quickly, as every second counts toward preventing injury or death. Keep these guidelines in mind:

- Brief passengers before leaving the dock on the proper procedures should someone fall overboard. Add this briefing to the passenger safety equipment overview.
- At the first sign that a person has fallen overboard, loudly yell “man overboard” and state which side of the boat such as “man overboard—port!” In heavy seas, throw a floatable item toward the MOB as quickly as possible to serve as a marker.
- The operator should immediately reduce speed and determine whether or not to come to a full stop or circle around.
 - If stopped, throw a flotation device (a throwable type is best, but any can be used) to the victim, shut down the engines, and throw the victim a line if necessary.
 - If circling around, assign one passenger to throw a flotation device as a marker, keep the victim in sight and continuously point to the victim. Carefully navigate back to the victim, staying at a safe distance, and position the boat safely to retrieve the victim. Keep current, wind and waves in mind so the victim drifts toward the boat. Shut down the engines and throw the victim a line if necessary.
- Move passengers to the rescue side of the boat to assist the victim back into the boat.
- Avoid going into the water to assist the victim unless there is no other way to retrieve the victim. If a rescuer must go into the water, the rescuer should be wearing a life jacket. The rescuer should also be prepared for the possibility of being pulled under water by the victim if the victim is panicking.

CAPSIZING AND FLOODING

A boat may capsize or flood when least expected. Formulate a plan in advance in case of capsizing or flooding.

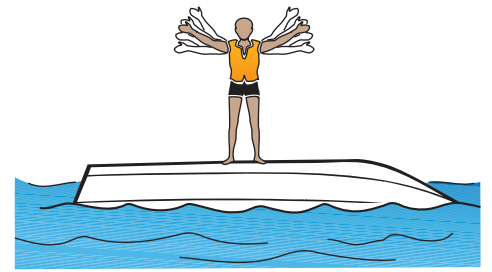

KC-0013C-A

Review the following guidelines:

- If the boat capsizes, locate all passengers and guide them to a safe flotation device or the forward hull if the boat is floating upside down.
- If possible, provide life jackets to all persons in the water and assess them for alertness and injuries.
- **STAY WITH THE BOAT!** Climb up on the hull and try to get assistance.
- Do not try to swim to shore, as it can be farther than it appears.

If the boat starts to flood, slow the boat to a safe speed and stop as quickly as possible. Activate the bilge pump(s) immediately. Try to locate the cause of the flooding. If the cause is not readily apparent or not easily corrected, head for shore or shallow water as quickly as possible and call for help.

RUNNING AGROUND

When a boat runs aground, the stop is usually abrupt. Because passengers are not secured to a seat, abruptly stopping a boat while in motion can cause serious personal injury or even death. First, turn off the engine(s) immediately, locate all passengers and attend to any injuries, calling for emergency assistance as needed. Then, assess the damage to the boat and determine if there are any other immediate threats such as water leaking into the boat, or fuel or flammable materials leaking into the water or inside the boat. Immediately call for assistance if threats exist that could endanger the safety of passengers.

If there are no immediate safety threats to passengers and the boat is not damaged, attempt to propel it away from the obstacle. If the engine or drive system has been damaged and the engine restarts, be aware of excessive vibrations or uncommon noises, which usually indicate damage to the drive system. If this is the case, it is not safe to proceed. Call for emergency or professional towing assistance immediately.



SECTION
4

EMERGENCIES

⚠ WARNING *Personal Injury Hazard: DO NOT attach tow lines to cleats, watersport line point, or eyes used for docking; use only designated strong points. Death or serious injury could occur if lines and/or hardware fail while they are under extreme tension.*

If the engine restarts and the boat can be navigated safely back to port, proceed slowly to port and be ready to call for emergency assistance if needed. Even if the boat and engine appear to be in good operating condition after running aground, have the boat inspected by a qualified marine technician BEFORE returning it to service. Damage may have occurred that is not obvious to you as an operator.

DANGEROUS WEATHER

Take special precautions when encountering or operating in dangerous or hazardous weather conditions.

See the *Severe Weather* section of this manual for additional information.

ENGINE OR BOAT SYSTEM FAILURE

In the event of an engine or boat system failure and when not in immediate danger, try to troubleshoot or identify the problem before calling for assistance.

See the *Troubleshooting* section of this manual for additional information.

ACCIDENTS, COLLISIONS AND GIVING ASSISTANCE

A collision or accident may occur when least expected. Formulate a course of action in advance in case of a collision or accident. Keep in mind the following guidelines:

- If an accident or collision occurs involving the boat, locate all passengers first and verify and secure their safety. Check for injuries and provide all passengers with a flotation device.
- After determining that passengers are not in danger, provide assistance to passengers on the other boat.
- Immediately call for help and then assess the damage to the boats. Render necessary assistance to prevent further damage or personal injury.

The USCG requires the owner/operator of a boat involved in an accident to report the incident immediately to the proper marine law enforcement agency for the state in which the accident occurred.

See the *Reporting Accidents* section of this manual for additional information.

An operator who witnesses or is aware of an accident or collision while boating must report it immediately and provide assistance.

Operators seeing a distress signal or suspecting a boat is in trouble must assume it is a real emergency and render assistance immediately. After determining that a real emergency exists, call for help immediately and then provide assistance to all passengers to ensure their safety.

TOWING ON THE WATER

In situations where an operator is asked to tow or be towed for any reason, assess the situation and

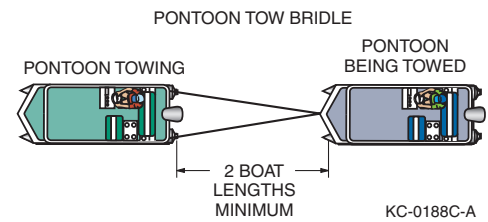

try to contact a professional towing service or other emergency assistance first. When encountering a boat in distress, always offer emergency or safety assistance and/or call for assistance for the distressed parties if necessary. Towing or being towed presents an increased risk of personal injury and boat damage.

⚠ WARNING *Personal Injury Hazard: DO NOT attach tow lines to cleats, watersport line point, or eyes used for docking; use only designated strong points. Death or serious injury could occur if lines and/or hardware fail while they are under extreme tension.*

⚠ WARNING *Towing another vessel with a Barletta pontoon boat is not recommended.*

Follow these guidelines when towing or being towed:

- Use extreme caution when throwing weighted lines to a boat in distress. When in rough seas, use a light throwing line with a weight secured on the throwing end and a heavier towing line secured to the other end.
- Never attempt to tow a boat larger or heavier than your own.

- Never attempt to tow a grounded, damaged or capsized boat.
- Use a tow line that is rated at least four times the gross weight of the boat being towed.
- Make sure tow lines are in good condition and are free of damage, cuts or abrasions.
- Attach a tow line to the designated strong point on the disabled boat. Never attach a tow line to any point on the disabled boat other than the designated strong point. Strong points are typically the bow and stern eyes on boats under 26' and are usually labeled.
- When attaching to the stern strong points, wrap the tow line with chafing gear where it rubs against the boat or any corners.
- Leave at least two boat lengths between the boats for adequate movement.
- Never allow anyone to be in line with the tow line. If the line breaks, pulls free or the hardware fails, dangerous recoil could occur, resulting in severe injury or death to anyone in its path.
- Adjust the tow line to match wave action. Keep the boats on the crest or in the trough of the waves at the same time. In protected, calm waters, shorten the line for better handling.
- Tow at moderate speed, allowing for adverse wind and wave conditions.
- Have the operator of the towed boat steer with you if possible.
- Have a person on the tow boat watch the disabled vehicle and, if necessary, be available to signal the operator of the disabled boat.

Check with local and state authorities prior to towing for additional regulations and restrictions on towing other boats or equipment.

Pontoon boats pose an additional challenge during slow-speed maneuvering in breezy conditions. The combination of light weight and high side-surface area can produce a “sail” effect that pushes the boat around, making docking especially tricky at times. If you feel the boat being pushed adversely when approaching the dock, it may be necessary to “abort” the maneuver and circle around for a different approach.

LAW OF SALVAGE

If boaters require assistance while cruising in the Great Lakes, coastal or ocean waters, they should use caution **before** allowing any towing company or private agency to pass a line to the boat. The law of salvage says, among other things, “...any vessel, if rendered assistance from a towing company or private agency, can be forced to relinquish a portion of the vessel’s worth for the assistance received.” While this is very rare with recreational boats, it can happen.

Before taking the line boaters must establish that they do not agree to any salvage rights and wish to be assisted on a contract basis. Boaters must then establish the contract price and payment terms. Boaters should accept the tow line only when the captain of the company/agency acknowledges the contract price and payment. Most tow companies are reputable and post terms and pricing on their websites.

If boating in the Great Lakes, coastal or ocean waters, it is a good idea to have a membership in a national towing service. This membership can significantly reduce the costs of towing if ever needed.

HURRICANE AND SEVERE WEATHER PREPAREDNESS

If keeping the boat in a region susceptible to hurricanes or severe weather (such as in the Great Lakes), have a well-thought-out plan for the boat long before the season starts. Consider the following:

- Boaters new to the area should talk to neighbors and local officials on what to expect.
- Boaters should talk to the dealer and marina about supplies, equipment and services available.
- Assemble the boat, contacts and insurance information and copy documents for safekeeping.
- If keeping the boat on the water, prepare a hurricane mooring package with extra lines, fenders and chafing protectors, as it is usually the boat owner’s responsibility to provide mooring gear in a marina. Plan on doubling the normal lines (bow, stern and spring) and fenders as a minimum. Remember, once a hurricane watch is posted, the local supply of lines and fenders will be quickly depleted.
- Remove electronics, canvas and loose items such as fighting chairs.
- Remove flammable, explosive or hazardous materials.



PROTECTING THE BOAT FROM THEFT

Thefts of boats, propulsion units and electronics are on the rise due to the high values and easy resale. While thieves still target boats on trailers at homes or on lake properties, marinas, storage facilities and dealerships are now being targeted because of the concentration of high-quality outboards and electronics available. Consider the following to make it difficult for thieves:

- Remove expensive electronics or cover with a sturdy, lockable cover.
- Use locking devices on outboard motor mounts and propellers.
- Use security fasteners that require a special tool for removal when mounting devices.
- Survey the marina or storage facility for obvious security lapses. Discuss concerns with personnel or find a new location.
- Talk to neighbors at home or the marina/ storage facility and provide them with a cell phone number and other contact information.
- If leaving the boat in the water, install a boat monitoring system with GPS tracking. Many propulsion unit manufacturers now offer this as an option on boats with electronic controls.
- Consult an insurance agent and local authorities for more recommendations.

Section 5

OPERATING IN HAZARDOUS CONDITIONS

Before operating the boat, review *Safety in Section 2*.

SEVERE WEATHER

Getting caught in severe weather can be dangerous and even fatal. Check with local weather stations, the USCG or weather-service broadcasts (162.55 or 162.40 MHz) for the latest conditions. Check the weather not only before you go out on the water, but also periodically while you are on the water. Consult the following websites for weather information:

- www.weather.com
- www.weather.gov
- www.navcen.uscg.gov

Enable National Oceanic and Atmospheric Administration (NOAA) weather alerts on radios, phones and other electronic devices for advance warnings. If weather is approaching, instruct all passengers to wear a life jacket; close all windows, hatches and doors; remain seated; use handholds and seek shelter in a safe harbor.

STORM CONDITIONS

Take the following precautions if operating the boat in storm conditions:

- Have all occupants wear life jackets.
- Turn on navigation lights.
- Locate and have inclement weather gear and safety equipment ready.
- Mark or identify the boat's position.
- Close all ports, stow all gear and secure any loose equipment on deck.
- Reduce speed and head for port or a safe, easily reachable place.
- Keep a lookout for debris and obstructions in the water.
- When possible, head into the waves at a 45-degree angle. Allowing high waves to strike the side of the boat may cause it to capsize or swamp.
- If losing power, keep the boat headed into the waves by rigging a sea anchor off the bow.
- If a storm cell with lightning cannot be avoided, lower antenna and take down fishing poles.

FOG CONDITIONS

Avoid operating the boat in foggy weather, if possible. Operators encountering fog conditions should return to port immediately. Also, take the following precautions:

- Reduce speed to a safe speed or idle.
- Take bearings and log the course and speed before the fog sets in. Use of a GPS is recommended.
- Have all occupants wear life jackets.
- Assign lookouts to the bow and stern to keep watch and listen.
- While navigating in fog, sound a five-second blast from the horn or whistle once every two minutes to alert other boaters of your position.
- If it is unsafe to continue navigating the boat, quickly find the best position to anchor. Sound a five-second blast from the horn or whistle once every minute while anchored to alert other boaters of your position.

REDUCED VISIBILITY

Natural environments and inclement weather can cause reduced visibility. Storm condition hazards can be compounded by reduced visibility while on the water. Always use common sense and take safety precautions if operating the boat in reduced visibility conditions.

COLD WEATHER

Avoid operating the boat in cold water or weather conditions, and never operate in frozen or icy waters. Operating in these conditions significantly increases the risk of serious injury or death. Boating in these conditions can lead to cold-water immersion, shock or hypothermia. Weather conditions may hinder emergency rescue or assistance, and cold weather poses potential problems for onboard equipment, as well as the engine. See the *Engine Operator's Manual* and the equipment manufacturer's instructions for operating in cold weather.

WATER HAZARDS

Every waterway poses hazards that operators must be aware of and avoid. These hazards include shallow water, rocks, tree stumps, sandbars and submerged/semi-submerged cables and pipes. Ask local authorities and other boaters for information and consult a marine chart when boating on unfamiliar waters. As a boat operator, try to avoid all hazards, known and unknown.



AQUATIC VEGETATION/WEEDS

Operating in weeded areas can be hazardous. Aquatic vegetation can be a threat to the boat's drive system. Vegetation and weeds can wrap around the propeller, causing loss of propulsion and steering control. They may also restrict the engine water cooling intake, causing the engine to overheat. Avoid operating in or near vegetation. If restricted because of vegetation, stop the engine. See the *Engine Operator's Manual* for recommendations on the removal of vegetation from the propeller and water cooling intake ports. Be extremely careful and never get into the water when clearing the propeller. Stay out of the water in highly congested vegetative areas, which can severely restrict your mobility and create a life-threatening situation.

NOTICE

Vegetation can sometimes be removed by shifting to NEUTRAL, pausing a moment, then shifting to REVERSE to unwind the vegetation from the propeller.

DAMS AND SPILLWAYS

The waterways around dams and spillways are extremely hazardous. Dams and spillways are subject to rapid water flow changes, and may have floating and sunken debris in the nearby water. These areas are often marked as restricted, and it is best to always stay clear of them.

SHALLOW WATER OPERATION



WARNING *Collision Hazard: Use caution in shallow water or where underwater/floating objects may be present. Hitting an object at high speed or severe angle can seriously injure people and damage the boat.*

Operating in shallow water presents a number of hazards. Sandbars in narrow inlets are constantly shifting, making it difficult to mark them with buoys. Sandbars are sometimes indicated by waves as they form into breakers when passing over the sandbar. In coastal areas, tides can affect water level as much as 30 feet (9 meters). Check with local marinas or Coast Guard stations for tide tables and current charts.

MARKERS, WARNINGS AND ADVISORIES

Find out from local authorities if hazards exist in areas where you intend to navigate, and know how these hazards are marked. You must also recognize flag designs that indicate hazards or activities that are present and keep well clear of those areas. Always watch for swimmers and stay clear of all swimming areas, marked or unmarked.



KC-0015C-B

Become familiar with navigation markers, which identify navigable routes and indicate water hazards. Always stay within marked boundaries and steer clear of hazards.

Flags and indicators are markers of potential emergencies and hazards. Become familiar with these flags and indicators. Additionally, understand your responsibilities when operating at these times and in these areas.



BOAT FLAGS

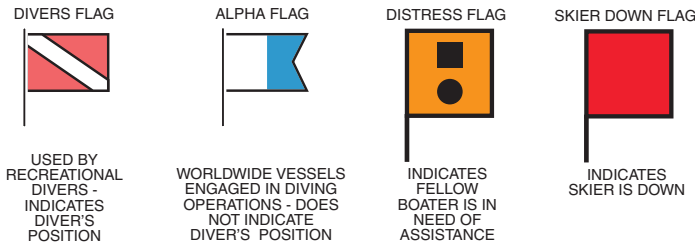

KCB-0013

Storm warning advisory flags and indicators alert boaters to impending weather conditions. Become familiar with these flags and indicators and understand the potential hazards associated with operating in these conditions.

HARBOR FLAGS AND INDICATORS

DAYTIME WARNING	DESCRIPTION	NIGHTTIME WARNING
	<p>Small Craft Advisory - Winds greater than 18 knots, sustained for two hours or more or hazardous wave conditions. Following a storm, hazardous wave conditions can persist long after the high winds have subsided.</p>	
	<p>Gale Warning - Sustained winds (2 or more hours), of 34-47 knots.</p>	
	<p>Storm Warning - Sustained winds of 48 knots or greater.</p>	
	<p>Hurricane Warning - Forecast winds of 64 knots and above. Displayed only in connection with a hurricane.</p>	

Actual Signal in red

KC-0371C



SECTION
5

OPERATING IN HAZARDOUS CONDITIONS

This Page Intentionally Left Blank

Section 6

NAVIGATION RULES AND AIDS

Before operating the boat, review *Safety in Section 2*.

The following information outlines basic navigational rules. Boating regulations are enforced by USCG, state and local authorities. You are subject to marine navigation regulations for both federal and state waterways. For more information, contact the USCG, state and local marine authorities. The navigational rules for U.S. waterways can be found in the “Navigational Rules” publication. This publication can be found at most marine supply stores, or you may contact the USCG or visit:

www.navcen.uscg.gov to view or download the publication.

RULES OF THE ROAD

RIGHT-OF-WAY

Boats with less maneuverability have right-of-way over more agile boats. You must stay clear of a boat with right-of-way. Examples of boats with right-of-way are:

- Boats aground or not under command
- Boats with restricted maneuverability
- Boats engaged in fishing
- Non-motor boats (having no power propulsion), i.e., rowboats, paddle boats, canoes and sailboats

Small pleasure boats must yield right-of-way to large commercial boats in narrow channels. A boat with right-of-way is sometimes referred to as the privileged boat.

The General Prudential Rule

The general prudential rule regarding right-of-way is if a collision appears unavoidable, neither boat has right-of-way. Both boats must act to avoid collision.

CROSSING

In crossing situations, the boat to the right from the 12 o'clock to the 4 o'clock position has the right-of-way and must hold course and speed. The boat without right-of-way must yield and pass to the stern of the privileged boat. Boats going up and down a river have the right-of-way over boats crossing the river.

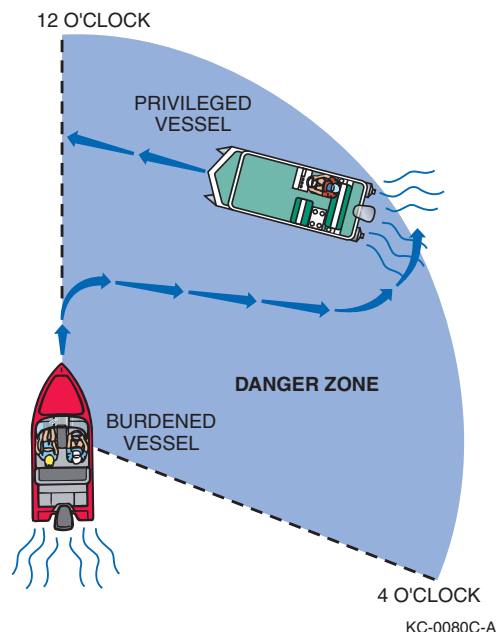



MEETING HEAD-ON

When two boats meet head-on, neither boat has the right-of-way. Both boats should decrease speed, turn to the right and pass port to port. If, however, both boats are on the left side of a channel, each vessel should sound two short horn blasts and pass starboard to starboard.

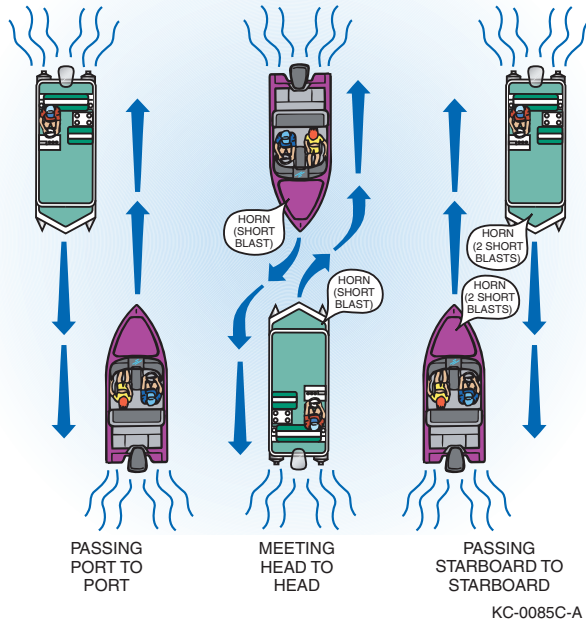

OVERTAKING / PASSING

The boat overtaking or passing must yield right-of-way to the boat being passed. The overtaking boat must make any adjustments necessary to keep out of the way of the boat being passed. The boat being passed has the right-of-way and must hold its course and speed.

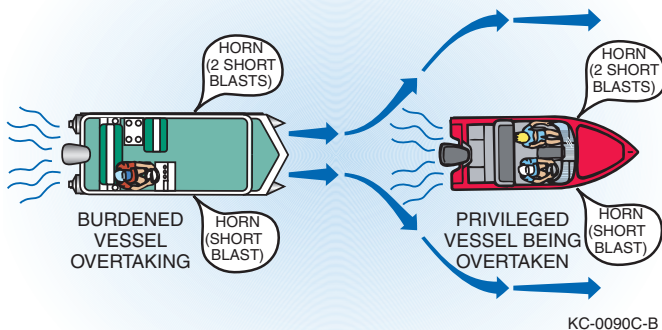

AUDIBLE SIGNALS

It is not necessary to sound a signal every time a boat is nearby. It is typical for commercial boat operators to signal their intention, using a whistle, horn or bell, to avoid potentially confusing or hazardous situations. Privileged boat operators customarily signal first, then the yielding boat operators return the same signal to acknowledge they understand and will comply. Use the danger signal (five or more short, rapid blasts) if intent is not clear.

Use the following signal blasts early enough so other boaters notice and understand them:

AUDIBLE DISTRESS SIGNAL	DEFINITION
One long blast	Warning signal (coming out of slip or passing astern)
One short blast	Pass on port side
Two short blasts	Pass on starboard side
Three short blasts	Engine(s) in reverse
Five or more short blasts	Danger signal

AIDS TO NAVIGATION

Learn to recognize the different buoys and day markers; they are the signposts of the waterways. The United States Aids to Navigation System (USATONS) is the primary marking system used on inland water, coastal waters and rivers. This system is maintained by the USCG.

There are two other navigation marking system variations boaters must follow in the United States:

- Western Rivers Marking System – When on the Mississippi River, tributaries above Baton Rouge, and several other rivers that flow toward the Gulf of Mexico.
- Intracoastal Waterway (ICW) – Runs just inland and parallel to the Atlantic Ocean and Gulf coasts from Manasquan, New Jersey, to the Mexican border. *Since ICW routes may travel next to non-ICW routes in opposing directions, navigate by the yellow symbols when following the ICW.*

Both systems are similar to USATONS but have subtle differences that must be understood. If you boat in these areas, visit www.uscgboating.org for navigation rules.



Navigational aids are designed and placed accordingly to help you navigate safely on the water. Learn to recognize the different buoys and day markers.

The following information is based on the USATONS. For further information, contact the USCG and state and local marine authorities. Also visit www.uscg.boating.org for navigation rules.

The USATONS uses buoys, beacons and minor lights as markers.

NEVER tie or anchor to a navigational aid. This action is unlawful and dangerous to you, your boat and other boaters.

NEVER move or damage a navigational aid. This action is unlawful and dangerous for other boaters.

BUOYS

Most anchored floating markers are generally referred to as buoys. Buoys have many uses and color schemes, and can vary in size and shape. The most commonly used buoy colors are white, red, green, yellow and black. Buoys may be unlighted or lighted. Some are audible; others have both an audible and a visual signal. Lights, bells and horns on buoys aid in night boating or poor visibility conditions. Buoys with unique light-flashing characteristics are identified on nautical charts with the specific flashing pattern.

Become familiar with the specific buoys used in the waters where you are boating. Contact local authorities for specific information and/or navigational aid charts for your waterways.

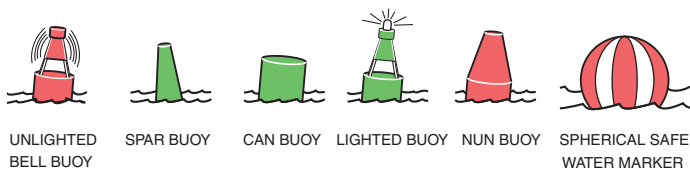

UNLIGHTED BELL BUOY

SPAR BUOY

CAN BUOY

LIGHTED BUOY

NUN BUOY

SPHERICAL SAFE WATER MARKER

KC-0052C-B

Mooring Buoys

The only buoys you are permitted to moor to are mooring buoys. Mooring buoys are white with a

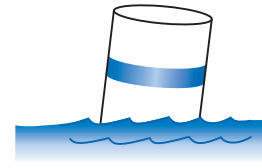

WHITE WITH BLUE BAND

MAY SHOW WHITE REFLECTOR OR LIGHT

KC-0020C-A

blue horizontal stripe. Check with local authorities before deploying a permanent mooring buoy. Mooring to a navigation buoy, regulatory markers or lateral markers is illegal.

DAYMARKS / DAYBOARDS

Daymarks or dayboards are fixed visual markers in the water.



STARBOARD DAY MARKER

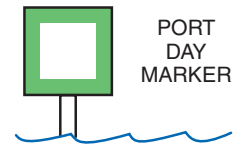

PORT DAY MARKER

KC-0021C-A

The markers are commonly attached to a post or piling and are sometimes accompanied by a light. Daymarks are either red or green and are usually triangular- or square-shaped, though their shapes can vary. Daymarks often display numbers, which act as navigation guides. Red daymarks are usually triangular and sometimes show an odd number. Green daymarks are usually square and sometimes show an even number. The numbers on the markers are sequential and increase from seaward.

LIGHTS AND LIGHTED STRUCTURES

Maneuvering a boat at night can be dangerous and confusing. To aid boaters with navigation and to warn of hazards, the USCG and state and local authorities maintain a variety of light structures. Some light structures are equipped with radio beacons, radar reflectors and/or fog signals.

Minor Lights

Minor lights are colored according to the buoyage marking system in use. They are similar to lighted buoys, except they are usually higher and on more stable platforms to increase visibility. Most minor lights are part of a series to mark a channel, river, or harbor and fairways.



Range Lights

Range lights are usually visible in one direction and help a boat operator navigate safely. Steering a course to keep range lights arranged in a line (one on top of the other) will help guide a boat through a channel.

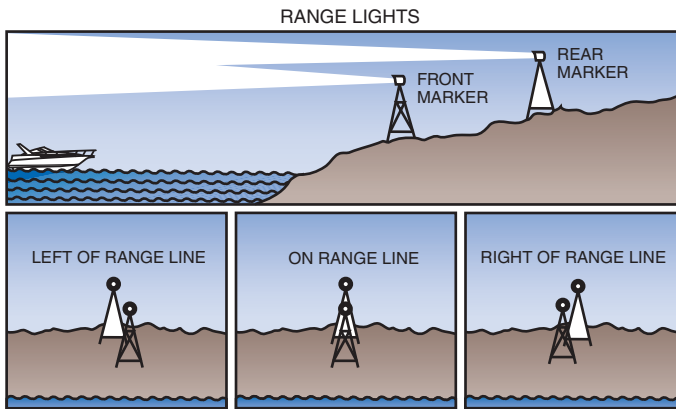

KC-0022C-A

Lighthouses

Lighthouses can be found at harbor entrances, prominent headlands, isolated danger areas and along the coasts. These striped or patterned structures have unique flashing signals, which help boaters identify them.

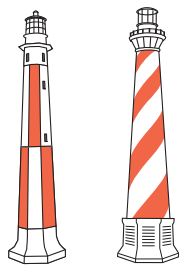

KC-0023C-B

MARKERS

Seven (7) types of markers are used to assist the boat operator:

- Regulatory
- Range
- Special
- Lateral
- Safe Water
- Preferred Channel
- Isolated Danger

Regulatory Markers

Regulatory markers are used to display information or indicate danger. Regulatory markers can be fixed visual markers or anchored floating buoys.

Fixed visual markers are usually white with orange geometric shapes that display information. Anchored floating buoys are white cylinder-shaped buoys with orange bands at the top and orange geometric shapes that may display information.

Following are the various orange geometric shapes used on these markers:

- Diamond – Indicates danger
- Diamond with cross marks inside – Indicates that a boater must keep away
- Circle – Indicates a controlled area or speed limit
- Square – Displays important information



DANGER

BOATS
KEEP OUTCONTROLLED
AREA

INFORMATION

KC-0244C-A

Range Markers

Range markers have many color schemes, may have numbers or letters and may be lighted or unlighted. They are placed in pairs within close distance of each other. They are commonly used in channels to guide boats safely through the center or safe line of navigation. Keep range markers visually in line with each other while navigating the waterway to avoid obstacles or other invisible dangers.

Special Markers

Special markers are yellow and come in various styles and shapes. Lighted and unlighted daymarks and buoys vary in function. Many are used to display information and navigational direction rules. The most common special markers are those used in intercoastal waterways. Contact your state and local authorities for more information on special markers used in your boating area.



Lateral Markers

Lateral markers are used to mark the sides of navigable channels. They can be buoys, daymarks or minor lights, and are red and green in color. They can be lighted or unlighted and may or may not have numbers.

The basic nautical rule of lateral markers is the phrase “Red, Right, Returning.”

The term “sea” generally refers to the ocean or a large body of water. “Seaward” refers to traveling or pointing toward the sea or large body of water. “From seaward” refers to traveling from the sea or a large body of water inland or toward a smaller body of water.

When traveling seaward – keep red markers to your port (left) and green markers to your starboard (right).

When returning from seaward – keep red markers to your starboard (right) and green markers to your port (left).

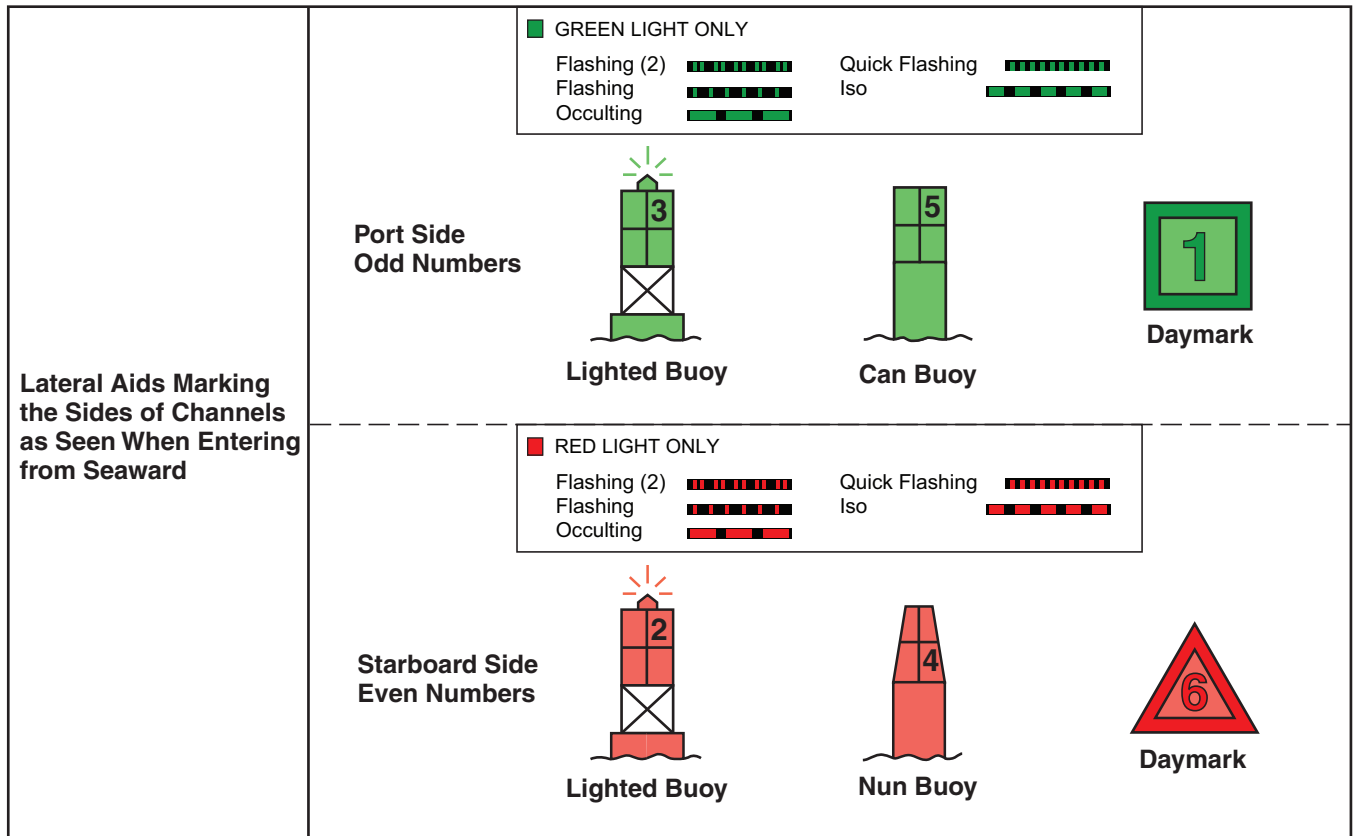

KCB0085







SECTION
6

NAVIGATION RULES AND AIDS

Safe Water Markers

Fairways and mid-channels may be marked with safe water markers or buoys. These markers indicate safe

water all around. Safe water markers are red and white with vertical stripes, and are round or have a red spherical top mark.

<p>Safe Water Aids Marking Mid-Channels and Fairways (No Numbers—May be Lettered)</p>	<p><input type="checkbox"/> WHITE LIGHT ONLY MORSE CODE</p> <p>Mo (A) </p>
	<div style="display: flex; justify-content: space-around; align-items: center;"> <div style="text-align: center;">  <p>Lighted</p> </div> <div style="text-align: center;">  <p>Spherical Buoy</p> </div> <div style="text-align: center;">  <p>Daymark</p> </div> </div>

KCB0086

Other Special Signs and Markers

Various signs and markers are used throughout U.S. waterways for different purposes. In Florida, special signs are used to warn of “manatee” areas. These signs help to control speed and/or restrict areas from boating to conserve this endangered species. As a boat owner and operator, be aware of special information and markers on the waterways. Contact your state and local authorities for more information on local restricted or controlled areas and their markers.



Preferred Channel Markers

Obstructions, channel junctions and preferred channels are marked with red and green horizontally striped can and nun-style buoys. The top band color

indicates the preferred path to take. Use these markers in the same manner as lateral markers to follow preferred channels.

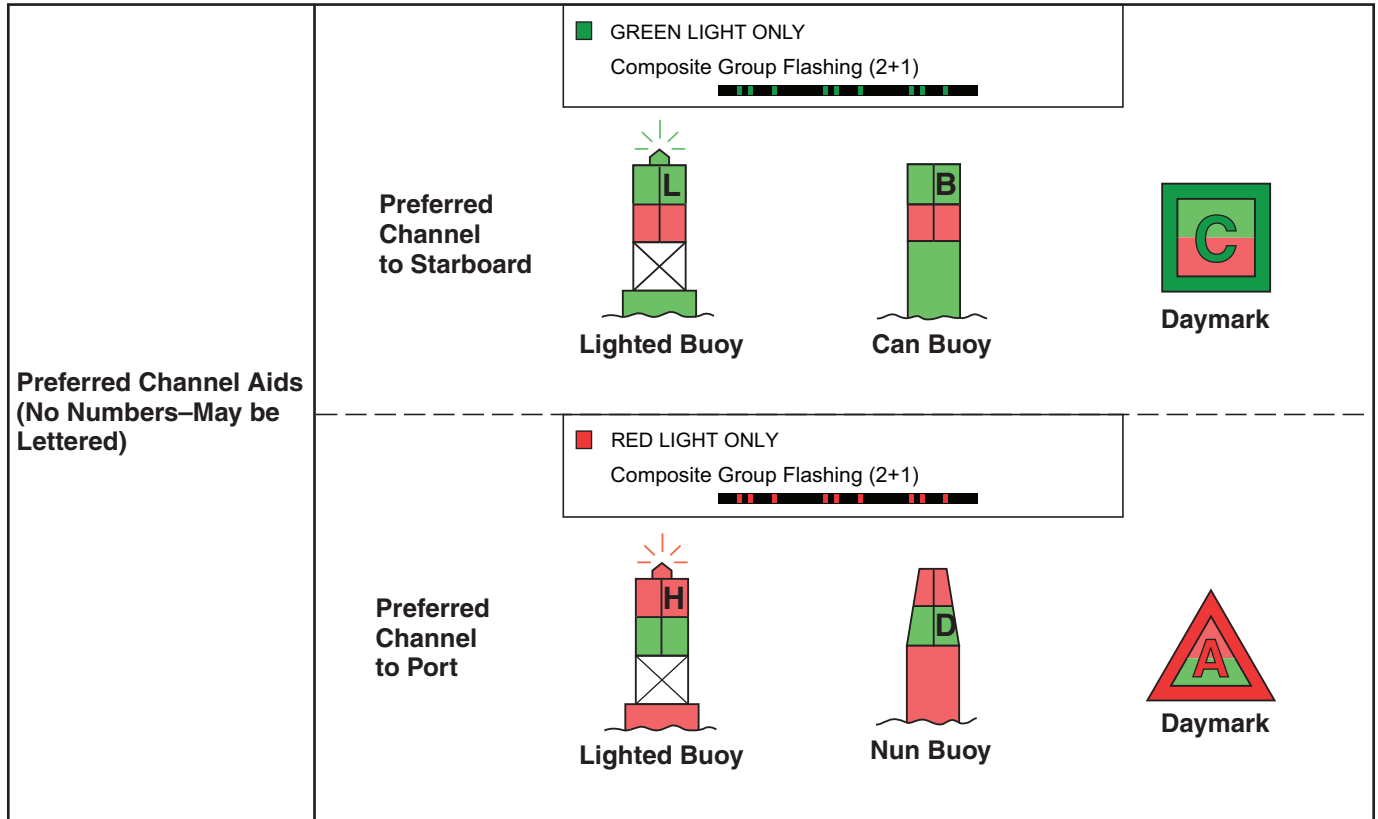

KCB0084



SECTION
6

NAVIGATION RULES AND AIDS

Isolated Danger Markers

Isolated danger markers indicate an isolated danger which may be passed on all sides. These markers are black with one or more broad horizontal red bands and are equipped with a top mark of two black spheres,

one above the other. On inland waters, a buoy with alternating vertical black and white stripes may be used to indicate that an obstruction or other danger exists between the buoy and the nearest shore. Do not pass between the buoy and the shore.

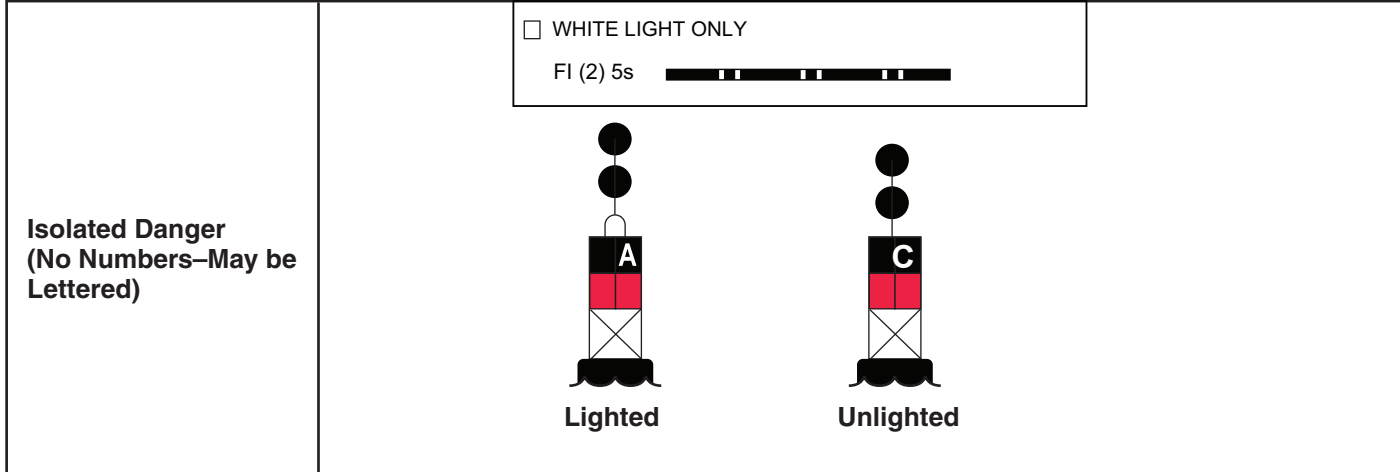

KCB0087



NAVIGATIONAL LIGHTS AND NIGHT OPERATION

Navigational lights are intended to alert other boats to your presence and course and their use is essential to boating safety and the prevention of collisions. Knowledge of navigation lights is necessary for the boat operator.

Regulations require that navigational lights be clearly lit and properly displayed at all times between sunset and sunrise, and always when operating in reduced visibility. Where applicable, lights must appear on the sides, stern, masthead and all-around positions. While underway, especially in congested areas, turn off any show lighting and lighted accessories.

All navigational rules apply at night, but speed is restricted on many waterways. Night boaters must operate at a slow, safe speed and stay clear of all boats, regardless of which boat has right-of-way.

Protect your night vision by avoiding bright lights and dimming courtesy lights. If possible, have a passenger help keep watch for other boats, water hazards, and aids to navigation.

The size, speed and direction of other boats are determined at night by white, green and red running lights.

- A green light indicates the starboard side of the boat. Generally, if you see a green light on another boat, you have the right-of-way. Hold your course.
- A red light indicates the port side of the boat. Generally, if you see a red light on another boat, they have right-of-way and you must yield your course.
- If you see both red and green lights, this indicates the boat is pointed towards you. Reduce speed and give a wide berth, usually on your port.
- A white light alone with no visible red or green lights indicates a boat at anchor and not making headway or a non-powered craft. Reduce speed and give a wide berth.

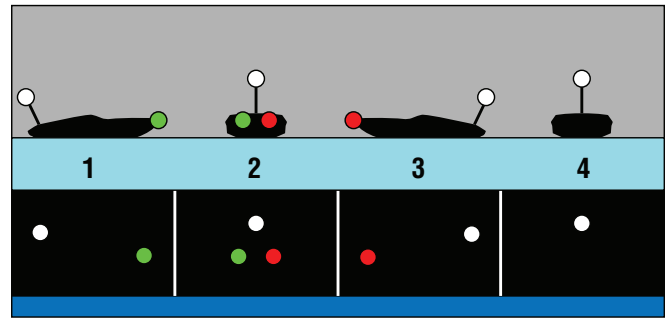

KCB-0104

1. Starboard Side; boat moving to the right
2. Bow; boat moving towards you
3. Port Side; boat moving to the left
4. Stern; boat anchored, non-powered or moving away

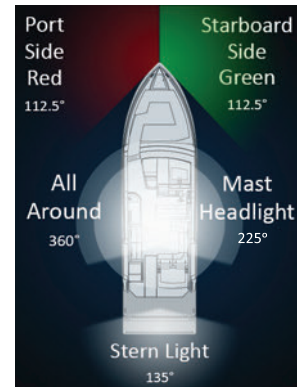

KCB-0105



SECTION

6

NAVIGATION RULES AND AIDS

This Page Intentionally Left Blank

Section 7

HELM AND CONTROLS

ABOUT THIS SECTION

The helm controls the main operations of your boat. It contains various systems including switches, gauges, MFD (multi-function displays), throttle and trim controls, to name just a few. The following pages contain a basic overview, and not all information will pertain to your specific boat.

See the *Engine Operator's Manual* or equipment manufacturer's guide (such as SIMRAD or optional thruster systems) for detailed information on the operation and maintenance of those systems. Some models may be equipped with MFD controls which integrate the functions of several systems into one or more displays.

Gauges and warning lights offer visual indicators that assist in monitoring your boat's systems. It's good practice to monitor these systems often while underway to ensure safe and worry-free operation.

RESERVE AND RESERVE LEGGERA



- | | |
|--------------------|-----------------------------------|
| 1. Fiberglass Helm | 6. Captain's Chair Pedestal |
| 2. Port Glovebox | 7. Steering Wheel Tilt Adjustment |
| 3. STBD Glovebox | 8. Toe Kick Access Panel |
| 4. Cup Holder | 9. Doggie Dish |
| 5. Storage Cubby | |

1. **FIBERGLASS HELM**
The main structure holding all boat controls. Made from durable fiberglass for strength and weather resistance.
2. & 3. **GLOVEBOX**
Small storage compartments good to store manuals, personal items or boating accessories.
4. **CUP HOLDER**
Holder for securing beverages.
5. **STORAGE CUBBY**
An open compartment for easily accessible storage of small items.
6. **CAPTAIN'S CHAIR PEDESTAL**
The base support for the captain's chair, providing swivel or height adjustment.
7. **STEERING WHEEL TILT ADJUSTMENT**
A control to change the steering wheel angle for personalized comfort.
8. **TOE KICK QUICK RELEASE**
A feature allowing for easier access or removal of panels.
9. **DOGGIE DISH**
A built-in pet-friendly feature of food or water bowls for your dog.



- | | |
|------------------------------------|--|
| 1. Windshield | 6. Horn Push Button |
| 2. SIMRAD® NSX 15" Digital Display | 7. Navigation/Anchor Light Push Button |
| 3. Ambient Light Sensor | 8. Diagnostic Port (Dealer Only) |
| 4. SIMRAD® NSX 7" Digital Display | 9. STBD Blower Vent |
| 5. Harman/Kardon® Audio System | 10. Steering Wheel |
| | 11. Port Blower Vent |
| | 12. Backlit RGB Helm |



SECTION
7

HELM AND CONTROLS

1. WINDSHIELD

Provides wind protection for the driver and reduces glare from the water.

2. SIMRAD® NSX 15" DIGITAL DISPLAY

Dual-screen drag-and-drop layout with SolarMax™ IPS display. Featuring engine and chart data, audio and entertainment control, quick, easy autorouting and advanced C-MAP® charting.

3. AMBIENT LIGHT SENSOR

Automatically enables navigation lights in dark or low-light conditions. Can be overridden by SIMRAD display.

4. SIMRAD NSX 7" DIGITAL DISPLAY

Dual-screen drag-and-drop layout with SolarMax™ IPS display. Featuring engine and chart data, audio and entertainment control, quick, easy autorouting and advanced C-MAP® charting.

5. HARMAN/KARDON® AUDIO SYSTEM

Delivers fully digital A2B, high fidelity marine audio with Bluetooth, zoned control EQ, IPX & waterproofing and a 4.3" readable display in sunlight. Exclusively tuned with use of digital sound processor.

6. HORN PUSH BUTTON

Activates the boat's horn for signaling other boaters.

7. NAVIGATION/ANCHOR LIGHT PUSH BUTTON

Control boat's navigation lights for low-light or nighttime operation.

8. DIAGNOSTIC PORT

Access point for technicians or dealer to plug in diagnostic tools for system checks or updates. (Mercury only).

9. & 11. BLOWER VENTS

Circulate ambient air through the helm area to reduce heat and moisture.

10. STEERING WHEEL

Main control for maneuvering the boat.

12. BACKLIT RGB HELM

Backlit customizable multi-color addressable LED lighting for a modern, ambient glow. User control with dynamic effects. Designed for evening/low-light cruises.

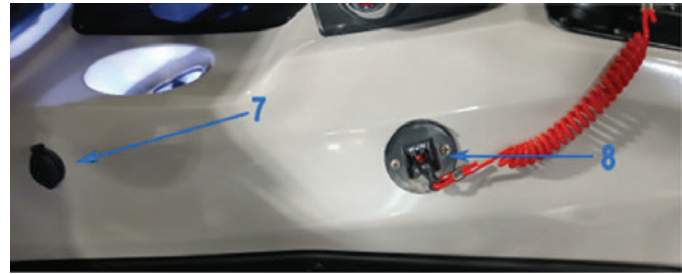

- | | |
|-------------------------|--------------------------|
| 1. Capacity Tag | 5. 12V Plug |
| 2. Arch Rocker Switch | 6. Remote Battery Switch |
| 3. Key Ignition | 7. USB Auxiliary Plug |
| 4. Bimini Rocker Switch | 8. Lanyard/Kill Switch |

1. CAPACITY TAG

Tag that lists the maximum number of people and total weight the boat can safely carry, as well as engine horsepower limits.

2. ARCH ROCKER SWITCH

Electronic switch that raises or lowers the arch.

3. KEY IGNITION PANEL

Area where the engine is started using a key.

4. BIMINI ROCKER SWITCH

Electronic switch that controls the bimini top, allowing adjustments for shade and coverage.

5. 12 VOLT PLUG

Port for charging devices and other accessories.

6. REMOTE BATTERY SWITCH

Main switch that turns the boat's electrical system on or off.



7. USB AUXILIARY PLUG

Port for charging devices or connecting media to the boat's entertainment system.

8. LANYARD/KILL SWITCH

A safety device that automatically shuts off the engine if pulled.

LUSSO AND LUSSO TWIN ENGINE



- | | |
|-----------------------------------|-----------------------------|
| 1. Fiberglass Helm | 7. Storage Cubby |
| 2. Port Glovebox | 8. Captain's Chair Pedestal |
| 3. STBD Glovebox | 9. Toe Kick Access Panel |
| 4. Steering Wheel Tilt Adjustment | 10. Doggie Dish |
| 5. USB Auxiliary Plug | |
| 6. Cup Holder | |

1. FIBERGLASS HELM

The main structure holding all boat controls. Made from durable fiberglass for strength and weather resistance.

2. & 3. GLOVEBOX

Small storage compartments good to store manuals, personal items and boating accessories.

4. STEERING WHEEL TILT ADJUSTMENT

A control to change the steering wheel angle for personalized comfort.

5. USB AUXILIARY PLUG

Port for charging devices or connecting media to the boat's entertainment system.

6. CUP HOLDER

Holder for securing beverages.

7. STORAGE CUBBY

An open compartment for easily accessible storage of small items.

8. CAPTAIN'S CHAIR PEDESTAL

The base support for the captain's chair, providing swivel or height adjustment.

9. TOE KICK QUICK RELEASE

A feature allowing for easier access or removal of panels.

10. DOGGIE DISH

A built-in pet-friendly feature of food or water bowls for your dog.



- | | |
|------------------------------------|--|
| 1. SIMRAD® NSX 12" Digital Display | 6. RGB Lighting Knob Control |
| 2. Ambient Light Sensor | 7. Navigation/Anchor Light Push Button |
| 3. SIMRAD® NSX 7" Digital Display | 8. STBD Hand Blower Vent |
| 4. JBL JAM 5000 Audio System | 9. Steering Wheel |
| 5. Horn Push Button | 10. Port Blower Vent |
| | 11. Backlit RGB Helm |

1. SIMRAD® NSX 12" DIGITAL DISPLAY

Dual-screen drag-and-drop layout with SolarMax™ IPS display. Featuring engine and chart data, audio and entertainment control, quick, easy autorouting and advanced C-MAP® charting.

2. AMBIENT LIGHT SENSOR

Automatically enables navigation lights in dark or low-light conditions. Can be overridden by SIMRAD display.



SECTION
7

HELM AND CONTROLS

- 3. SIMRAD NSX 7" DIGITAL DISPLAY**
Dual-screen drag-and-drop layout with SolarMax™ IPS display. Featuring engine and chart data, audio and entertainment control, quick, easy autorouting and advanced C-MAP® charting.
- 4. JBL JAM 5000 AUDIO SYSTEM**
The JBL JAM 5000 delivers Bluetooth, USB, AM/FM/WB audio, 3-zone control and a 2.8" color TFT screen—perfect for rugged, high-performance marine sound.
- 5. HORN PUSH BUTTON**
Activates the boat's horn for signaling other boaters.
- 6. RGB LIGHTING KNOB CONTROL**
Rotary controlled used to adjust color, brightness and mode of the boat's interior LED lighting system.
- 7. NAVIGATION/ANCHOR LIGHT PUSH BUTTON**
Control boat's navigation lights for low-light or nighttime operation.
- 8. & 10. BLOWER VENTS**
Circulate ambient air through the helm area to reduce heat and moisture.
- 9. STEERING WHEEL**
Main control for maneuvering the boat.
- 11. BACKLIT RGB HELM**
Backlit customizable multi-color addressable LED lighting for a modern, ambient glow. Designed for evening/low-light cruises.

LUSSO TWIN ENGINE

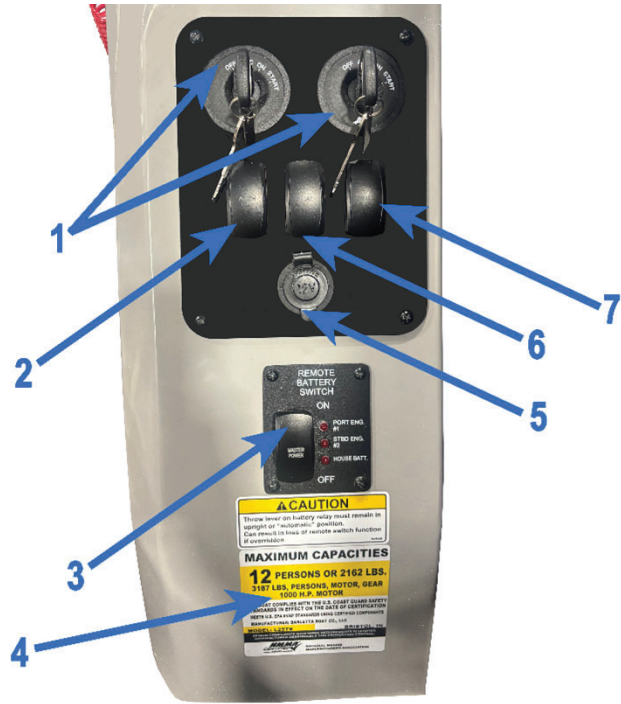

- | | |
|--------------------------|---|
| 1. Key Ignition | 5. 12V Plug |
| 2. Arch Rocker Switch | 6. Electric Pedestal Base Rocker Switch |
| 3. Remote Battery Switch | 7. Bimini Rocker Switch |
| 4. Capacity Tag | |

MERCURY JOYSTICK



NOTICE Refer to Mercury owner's manual for operation.



1. KEY IGNITION

Area where the engine is started using a key.

2. ARCH ROCKER SWITCH

Electronic switch that raises or lowers the arch.

3. REMOTE BATTERY SWITCH

Main switch that turns the boat's electrical system on or off.

4. CAPACITY TAG

Tag that lists the maximum number of people and total weight the boat can safely carry, as well as engine horsepower limits.

5. 12 VOLT PLUG

Port for charging devices and other accessories.

6. ELECTRICAL PEDESTAL BASE ROCKER SWITCH

Button that raises and lowers the captain's chair.

7. BIMINI ROCKER SWITCH

Electronic switch that controls the bimini top, allowing adjustments for shade and coverage.

LUSSO SINGLE ENGINE



- | | |
|-----------------------------|--------------------------|
| 1. Lanyard/Kill Switch | 5. 12V Plug |
| 2. Bimini Rocker Switch | 6. Remote Battery Switch |
| 3. Key Ignition | 7. Capacity Tag |
| 4. Bow Bimini Rocker Switch | |

1. LANYARD/KILL SWITCH

A safety device that automatically shuts off the engine if pulled.

2. BIMINI ROCKER SWITCH

Electronic switch that controls the aft canopy bimini top, allowing adjustments for shade and coverage.

3. KEY IGNITION

Area where the engine is started using a key.

4. BOW BIMINI ROCKER SWITCH

Electronic switch that extends or retracts the bow capacity bimini top.

5. 12 VOLT PLUG

Port for charging devices and other accessories.

6. REMOTE BATTERY SWITCH

Main switch that turns the boat's electrical system on or off.

**7. CAPACITY TAG**

Tag that lists the maximum number of people and total weight the boat can safely carry, as well as engine horsepower limits.

CORSA

- | | |
|-----------------------------------|-----------------------------|
| 1. Fiberglass Helm | 6. Accent Light |
| 2. Glovebox | 7. USB Auxiliary Plug |
| 3. Doggie Dish | 8. Captain's Chair Pedestal |
| 4. Toe Kick Access Panel | 9. Cup Holder |
| 5. Steering Wheel Tilt Adjustment | |

1. FIBERGLASS HELM

The main structure holding all boat controls. Made from durable fiberglass for strength and weather resistance.

2. GLOVEBOX

Small storage compartments good to store manuals, personal items or boating accessories.

3. DOGGIE DISH

A built-in pet-friendly feature of food or water bowls for your dog.

4. TOE KICK QUICK RELEASE

A feature allowing for easier access or removal of panels.

5. STEERING WHEEL TILT ADJUSTMENT

A control to change the steering wheel angle for personalized comfort.

6. COURTESY LIGHT

LED light placed in helm to provide soft lighting for visibility and safety during low-light conditions.

7. USB AUXILIARY PLUG

Port for charging devices or connecting media to the boat's entertainment system.

8. CAPTAIN'S CHAIR PEDESTAL

The base support for the captain's chair, providing swivel or height adjustment.

9. CUP HOLDER

Holder for securing beverages.

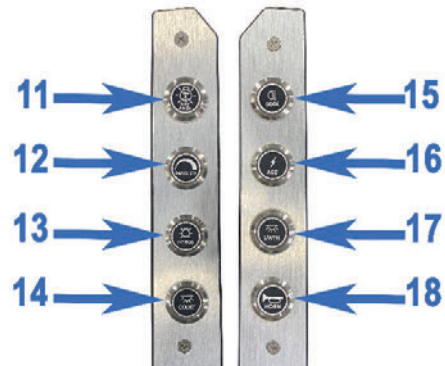
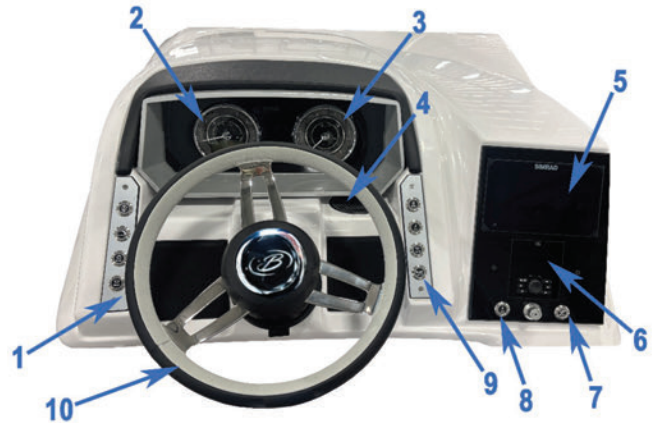

- | | |
|------------------------------------|-------------------------------------|
| 1. Port Switch Panel | 12. Panel Lights Push Button |
| 2. Tachometer | 13. Interior RGB Lights Push Button |
| 3. Speedometer | 14. Courtesy Light Push Button |
| 4. Wireless Charger | 15. Docking Light Push Button |
| 5. SIMRAD® NSX 7" Digital Display | 16. Underdeck Light Push Button |
| 6. JBL JAM 5000 Audio System | 17. Underwater Light Push Button |
| 7. Bilge Push Button | 18. Horn Push Button |
| 8. Accessory Push Button | |
| 9. STBD Switch Panel | |
| 10. Steering Wheel | |
| 11. Navigation /Anchor Push Button | |



1 & 9. PORT/STBD SWITCH PANELS

Controls various electrical systems on the boat, such as lights or pumps.

2. TACHOMETER

Displays the engine's revolutions per minute (RPM), helping monitor engine performance.

3. SPEEDOMETER

Shows the current speed of the boat.

4. WIRELESS CHARGER

A pad for wirelessly charging compatible smartphones and devices.

5. SIMRAD NSX 7" DIGITAL DISPLAY

Dual-screen drag-and-drop layout with SolarMax™ IPS display. Featuring engine and chart data, audio and entertainment control, quick, easy autorouting and advanced C-MAP® charting.

6. JBL JAM 5000 AUDIO SYSTEM

The JBL JAM 5000 delivers Bluetooth, USB, AM/FM/WB audio, 3-zone control and a 2.8" color TFT screen—perfect for rugged, high-performance marine sound.

7. BILGE PUSH BUTTON

Activates the bilge pump to remove water from the bilge area.

8. ACCESSORY PUSH BUTTON

Auxiliary button for controlling additional after market accessories or custom features.

10. STEERING WHEEL

Main control for maneuvering the boat.

Switch Column Left of Wheel

11. NAVIGATION/ANCHOR LIGHTS

NAV - Navigation lights on the port (red) and starboard (green)
 ANCH - "Anchor" light (white) located on top of the bimini.



12. PANEL LIGHTS

Dashboard gauge and button lights.



13. INTERIOR RGB LIGHTS

Lights that illuminate cup holders, speakers and accent lights.



14. COURTESY LIGHTS

White lights located on console and bimini to help passengers walking on boat after dusk.



Switch Column right of Wheel

15. DOCKING LIGHT

Bright white light pointed forward to help with docking after dusk.
 Not to be used while underway, only docking.



16. UNDERDECK LIGHTS

While underdeck lighting.



17. UNDERWATER LIGHTS

White underwater lights that illuminate stern area.



18. HORN

Sounds boat horn.



- 1. Lanyard/Kill Switch
- 2. Key Ignition
- 3. 12V Plug
- 4. Bow Bimini Rocker Switch
- 5. Aft Bimini Rocker Switch

1. LANYARD/KILL SWITCH

A safety device that automatically shuts off the engine if pulled.

2. KEY IGNITION

Area where the engine is started using a key.

3. 12 VOLT PLUG

Port for charging devices and other accessories.



SECTION
7

HELM AND CONTROLS

4. BOW BIMINI ROCKER SWITCH

Electronic switch that controls the bow canopy bimini top, allowing adjustments for shade and coverage.

5. AFT BIMINI ROCKER SWITCH

Electronic switch that controls the aft canopy bimini top, allowing adjustments for shade and coverage.

CABRIO



- | | |
|-----------------------------------|---|
| 1. Fiberglass Helm | 7. Captain's Chair Pedestal |
| 2. Cup Holder | 8. Toe Kick Access Panel |
| 3. Wireless Phone Charger | 9. Doggie Dish |
| 4. Steering Wheel Tilt Adjustment | 10. Courtesy Light (Push to enable/disable) |
| 5. USB Auxiliary Plug | |
| 6. Helm Warning Label | |

1. FIBERGLASS HELM

The main structure holding all boat controls. Made from durable fiberglass for strength and weather resistance.

2. CUP HOLDER

Holder for securing beverages.

3. WIRELESS PHONE CHARGER

A pad for wirelessly charging compatible smartphones and devices.

4. STEERING WHEEL TILT ADJUSTMENT

A control to change the steering wheel angle for personalized comfort.

5. USB AUXILIARY PLUG

Port for charging devices or connecting media to the boat's entertainment system.

6. HELM WARNING LABEL

Seat adjustment safety warning.

7. CAPTAIN'S CHAIR PEDESTAL

The base support for the captain's chair, providing swivel or height adjustment.

8. TOE KICK ACCESS PANEL

A feature allowing for removal of panels for service access.

9. DOGGIE DISH

A built-in pet-friendly feature of food or water bowls for your dog.

10. COURTESY LIGHT

Light installed on the helm. Provides light to help passengers move around in low-light conditions and arch lights (if equipped). Push to enable or disable.

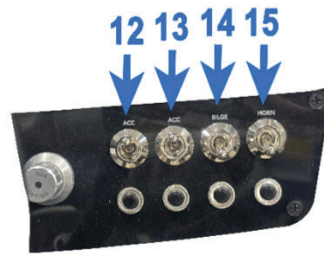

1. Port Switch Panel
2. Tachometer
3. Speedometer
4. LOWRANCE® Eagle 5 Chart Plotter (Image shown with optional SIMRAD® GO7 Digital Display)
5. JBL JAM 5000 Audio System
6. STBD Switch Panel
7. Steering Wheel

8. Docking Light Switch
9. Courtesy Light Switch
10. Navigation/Anchor Light Switch
11. Accessory Switch
12. Accessory Switch
13. Accessory Switch
14. Bilge Switch
15. Horn Switch



SECTION
7

HELM AND CONTROLS

1 & 6. SWITCH PANELS

Controls various electrical systems on the boat, such as lights or pumps.

2. TACHOMETER

Displays the engine's revolutions per minute (RPM), helping monitor engine performance.

3. SPEEDOMETER

Shows the current speed of the boat.

4. LOWRANCE® EAGLE 5 CHART PLOTTER

5-inch screen with GPS chart plotting and imaging, giving a clear navigation and underwater views. Designed for easy access and reliable performance. Coverage depends on installed chart card.

OPTIONAL SIMRAD® GO7 DIGITAL DISPLAY

7 inch touchscreen unit that combines GPS navigation, sonar, and engine data (if equipped). It enhances the captain's control with intuitive menus, split-screen functionality, and integration with other onboard systems

5. JBL JAM 5000 AUDIO SYSTEM

The JBL JAM 5000 delivers Bluetooth, USB, AM/FM/WB audio, 3-zone control and a 2.8" color TFT screen—perfect for rugged, high-performance marine sound.

7. STEERING WHEEL

Main control for maneuvering the boat.

Arrangement on Left Panel



8. DOCKING LIGHT

Bright white light pointed forward to help with docking after dusk. Not to be used while underway, only docking.



9. COURTESY LIGHTS

White lights located on console and bimini to help passengers walking on boat after dusk.

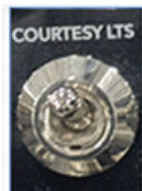

10. NAVIGATION/ANCHOR LIGHTS

NAV - Navigation lights on the port (red) and starboard (green)
ANCH - "Anchor" light (white) located on top of the bimini.



Alignment on Right Panel



11. & 12 & 13 ACCESSORY

Available switch for future feature add-on.



14. BILGE PUMP

Electric water pump for removing water from ski locker located in center pontoon.



15. HORN

Sounds boat horn.

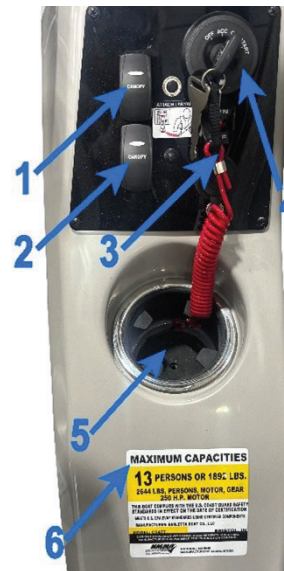
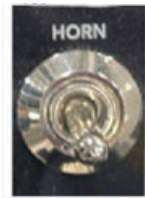

- | | |
|------------------------------------|-----------------|
| 1. Bimini Rocker Switch | 4. Key Ignition |
| 2. Additional Bimini Rocker Switch | 5. Cup Holder |
| 3. Layard/Kill Switch | 6. Capacity Tag |



1. **BIMINI ROCKER SWITCH**
Electronic switch that controls the canopy bimini top, allowing adjustments for shade and coverage.
2. **ADDITIONAL BIMINI ROCKER SWITCH**
Electronic switch that controls the second bimini top, allowing adjustments for shade and coverage. For double bimini only.
3. **LANYARD/KILL SWITCH**
A safety device that automatically shuts off the engine if pulled.
4. **KEY IGNITION**
Area where the engine is started using a key.
5. **CUP HOLDER**
Holder for securing beverages.
6. **CAPACITY TAG**
Tag that lists the maximum number of people and total weight the boat can safely carry, as well as engine horsepower limits.

ARIA



1. Fiberglass Helm
2. Courtesy Light (Push to enable/disable)
3. JBL JAM 3000 Audio System
4. Toe Kick Access Panel

5. Steering Wheel Tilt Adjustment
6. Cup Holder
7. Capacity Tag
8. Captain's Chair Pedestal

1. **FIBERGLASS HELM**
The main structure holding all boat controls. Made from durable fiberglass for strength and weather resistance.
2. **COURTESY LIGHT**
Light installed on the helm. Provides light to help passengers move around in low-light conditions and arch lights (if equipped). Push to enable or disable.
3. **JBL JAM 3000 AUDIO SYSTEM**
The JBL JAM 3000 delivers Bluetooth, USB and AM/FM/WB audio, — perfect for rugged, high-performance marine sound.
4. **TOE KICK ACCESS PANEL**
A feature allowing for removal of panels for service access.
5. **STEERING WHEEL TILT ADJUSTMENT**
A control to change the steering wheel angle for personalized comfort.



SECTION
7

HELM AND CONTROLS

6. CUP HOLDER

Holder for securing beverages.

7. CAPACITY TAG

Tag that lists the maximum number of people and total weight the boat can safely carry, as well as engine horsepower limits.

8. CAPTAIN'S CHAIR PEDESTAL

The base support for the captain's chair, providing swivel or height adjustment.

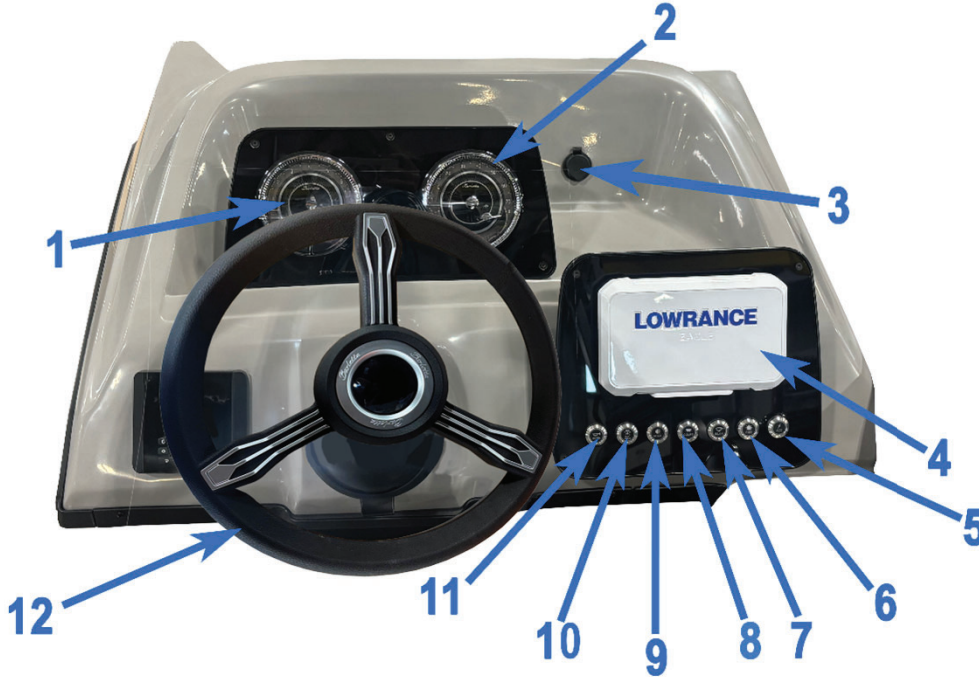

- 1. Tachometer
- 2. Speedometer
- 3. USB Auxiliary Plug
- 4. LOWRANCE® Hook 4 Chart Plotter
- 5. ACC Push Button
- 6. RGB Light Push Button

- 7. Bilge Push Button
- 8. Courtesy Light Push Button
- 9. Docking Light Push Button
- 10. Navigation/Anchor Light Push Button
- 11. Horn Push Button
- 12. Steering Wheel

1. TACHOMETER

Displays the engine's revolutions per minute (RPM), helping monitor engine performance.

2. SPEEDOMETER

Shows the current speed of the boat.

3. USB AUXILIARY PLUG

Port for charging devices or connecting media to the boat's entertainment system.

4. LOWRANCE® HOOK 4 CHART PLOTTER

4-inch screen fish-finder with GPS navigation and sonar imaging.

OPTIONAL LOWRANCE® EAGLE 5 CHART PLOTTER

5-inch screen with GPS chart plotting and imaging, giving a clear navigation and underwater views. Designed for easy access and reliable performance.

OPTIONAL SIMRAD® GO7 DIGITAL DISPLAY

7 inch touchscreen unit that combines GPS navigation, sonar, and engine data (if equipped). It enhances the captain's control with intuitive menus, split-screen functionality and integration with other onboard systems.

12. STEERING WHEEL

Main control for maneuvering the boat.



Button Arrangement on Console



5. ACCESSORY

Available switch for future feature add-on.

6. RGB LIGHTS

RGB Lighting on/off if optioned.

If RGB Lighting not optioned, available switch for future feature add-on.

7. BILGE PUMP

Electric water pump for removing water from ski locker located in center pontoon.

8. COURTESY LIGHTS

White lights located on console and bimini to help passengers walking on boat after dusk.

9. DOCKING LIGHT

Bright white light pointed forward to help with docking after dusk. Not to be used while underway, only docking.

10. NAVIGATION/ANCHOR LIGHTS

NAV - Navigation lights on the port (red) and starboard (green)
 ANCH - "Anchor" light (white) located on top of the bimini.

11. HORN

Sounds boat horn.

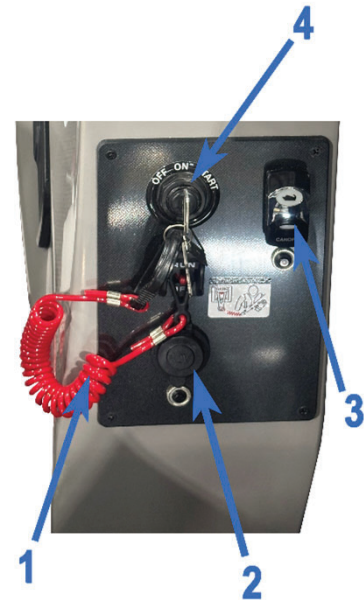

- 1. Lanyard/Kill Switch
- 2. 12V Plug
- 3. Bimini Rocker Switch
- 4. Key Ignition

1. LANYARD/KILL SWITCH

A safety device that automatically shuts off the engine if pulled.

2. 12 VOLT PLUG

Port for charging devices or other accessories.

3. BIMINI ROCKER SWITCH

Electronic switch that controls the canopy bimini top, allowing adjustments for shade and coverage.

4. KEY IGNITION

Area where the engine is started using a key.

SHIFT AND THROTTLE CONTROLS

Knowing how to operate the shift and throttle controls of the boat is essential for safe and proper operation.

The following basic and typical information may not apply to your specific control. See the *Engine Operator's Manual* or control manufacturer's instructions for information on your throttle and shift control operation, adjustment and maintenance.

WARNING *Control Hazard: Always use extreme caution when using a single-lever binnacle control. These controls may not have a neutral lockout position or a neutral detent. These controls can accidentally move from Forward to Reverse or Reverse to Forward easily. This could result in a control hazard.*

NEUTRAL START SAFETY SWITCH

The neutral start safety switch provides start-in-gear prevention. The switch controls power to the engine starter circuit of the ignition switch. The engine gear shift control lever must be in the NEUTRAL position to allow the ignition switch to activate the engine starter. This safety device will prevent the boat's engine from starting if the engine is in gear. Most throttle/shift controls have this feature.

CONTROL OPERATION GUIDELINES

WARNING *Control Hazard: Improperly maintained controls are hazardous and may cause sudden loss of control. Make sure all shift/throttle hardware and cables are regularly inspected and maintained. Improper maintenance may result in a loss of control.*

- Side mount throttle and shift controls have a neutral detent locking lever that must be released before shifting from NEUTRAL.
- Always use a brisk and decisive movement when shifting into or out of gear.
- Always pause in NEUTRAL before shifting from FORWARD to REVERSE, or REVERSE to FORWARD. Most throttle and shift controls have a detent position for NEUTRAL, FORWARD and REVERSE engagement positions. Engine damage may occur if you rapidly shift into gear without pausing in these detent positions or allowing the engine RPM to lower into the approved shifting range.
- When traveling at high speed, never shift into REVERSE while your boat is in FORWARD gear.

- Always keep the shift control clean and clear of obstruction.

NOTICE

Most shift and throttle controls are equipped with a safety switch for start-in-gear prevention. Place the control in the NEUTRAL position before you attempt to start the engine.

- Never attempt to shift when the engine is not running.

SINGLE-LEVER CONTROLS - SINGLE OR TWIN ENGINE

NEUTRAL – The lever is detected in the NEUTRAL position (center of travel) for starting; the neutral safety switch allows starting in this position only. For engine warm-up, a separate lever or button on the control is used to disengage the shift cable and allow the throttle to advance only while the transmission remains in NEUTRAL.

FORWARD – Release the detent lock to allow shifting to the FORWARD position. Moving the lever into the first 15 degrees of travel (toward the bow or up) positions the control in the FORWARD detent IDLE position. Advancing the lever beyond 15 degrees allows throttle increase in FORWARD.

REVERSE – Release the detent lock to allow shifting to the REVERSE position. Moving the lever into the first 15 degrees of travel (toward the stern or down) positions the control in the REVERSE detent idle position. Advancing the lever beyond 15 degrees allows throttle increase in REVERSE.

Single-lever controls operate both the gear shift and the throttle for one or two engines with one control lever.

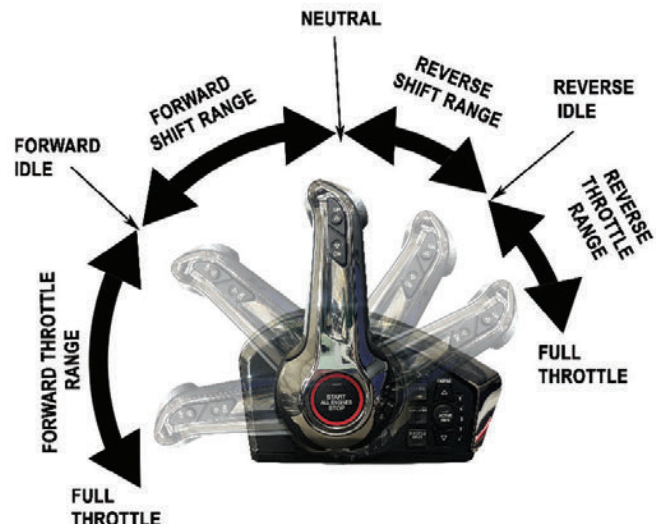



EASY DOCK THRUSTER SYSTEM

Designed to make docking and maneuvering significantly easier, especially in tight spaces or challenging conditions, the Easy Dock Thruster System is controlled via intuitive buttons at the helm, allowing for precise control of the boat's movements. The thruster switch panel, located on the left side of the steering wheel, includes bow and stern thrusters that can move the boat sideways or pivot it in place.

Only available on Reserve, Reserve Leggera, and Lusso models.

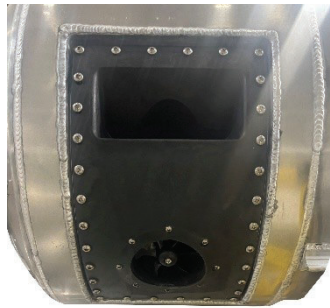

- 1. System Power and Reverse Flush
- 2. Bow Thruster Port and Starboard
- 3. Stern Thruster Port and Starboard

NOTICE Refer to Thruster owner's manual for operation.

TRIM / TILT SWITCH

The trim function on an outboard motor moves the lower unit of the engine, including the propeller, either away from the boat (up) or towards the boat (down). This feature can serve many functions but is most commonly used to make sure the engine does not hit the bottom in shallow waters.

Trimming the engine is also a great way to operate at peak performance. Once you get experienced with this function, you can manipulate the engine to get more speed, a smoother ride and on plane quickly.

This switch is located on the throttle/binnacle, to the right of the captain's chain. These switches often have different configurations based on your engine manufacturer and type.



TRIM / TILT GAUGE

The power trim/tilt gauge indicates the angular position of the lower drive unit and propeller in relation to the transom of the boat via CANBUS.

VOLTMETER

The voltmeter indicates the voltage of the main cranking battery in volts DC via CANBUS. See the *Engine Operator's Manual* for the normal operating range.

HOUR METER

The engine hour meter indicates the total number of hours the ignition switch is in the ON position via CANBUS. Under normal conditions, the engine is running when the ignition switch is ON; therefore, the hour meter provides an approximate indication of engine hours. An hour meter is useful in determining scheduled maintenance.



ENGINE CUT-OFF SWITCH AND LINK

The engine cut-off switch (ECOS) and engine cut-off switch link (ECOSL) control the engine ignition ON/OFF. These safety devices shut the engine off immediately and prevent the boat from becoming a runaway if the operator is accidentally thrown from the seat or away from the helm.

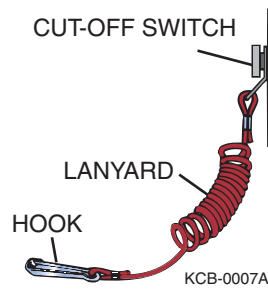

Whenever the boat's engine is on, physically secure one end of the engine cut-off switch lanyard to the cut-off switch and the other to the boat operator. Some optional systems use a wireless FOB attached to the operator. If the operator is thrown from the seat or moves too far from the helm, the lanyard will disconnect from the switch, activating the switch to turn off the engine.

⚠ WARNING *Control Hazard: Never remove or modify the engine cut-off switch and/or lanyard.*

- ***Always check the switch for proper operation. With the engine running, pull the lanyard. If the engine does not stop, have the switch repaired before continuing to operate the boat. Never operate the boat if the engine cut-off switch does not work.***
- ***Attach the engine cut-off switch cord lanyard or fob to a secure place on your clothing, your arm or leg while operating.***
- ***Avoid accidentally pulling the cord lanyard during normal operation. Loss of engine power means loss of most steering control. Also, without engine power, the boat could slow rapidly. This could cause people and objects in the boat to be thrown forward.***
- ***DO NOT attach the cord lanyard to clothing that could tear loose. DO NOT route the cord lanyard where it could become entangled, preventing it from functioning.***

Section 8

BOAT FEATURES AND OPTIONS

Before operating any systems within this section, review *Safety in Section 2*.

The boat may be equipped with a variety of systems to operate the boat and to provide other conveniences you may need while on the water. The following basic and typical information may not apply to your specific application. All of the boat's systems may not be covered in this section. See the *Equipment Manufacturer's Operator's Manual* for specific details.

Regularly inspect and maintain all components and systems to prevent unexpected hazards due to worn or faulty components. Be sure to replace components and hardware with marine-grade parts.

 **WARNING** *Fire/Explosion Hazard: Never use parts not specified for marine use to replace marine-grade parts. Using non-marine specified parts in a marine environment may result in a fire and/or explosion.*

ELECTRICAL SYSTEM

Boats may be equipped with one or two types of electrical systems: Direct Current (DC) and Alternating Current (AC).

Most boats use a battery-powered direct current (DC) system; some boats also use a generator or shore-powered alternating current (AC) system. Most systems have a main load panel which serves as the main distribution panel.

DC SYSTEM

 **WARNING** *Fire/Explosion Hazard: Always use caution when operating and maintaining the DC electrical system. Fire or explosion may result from improper use of the DC electrical system.*

Most boats use a 12-volt common negative ground DC system. DC systems are usually the primary electric supply for lights, pumps, blowers, engine starting, etc.

Boats require at least one battery per engine. Multiple-battery systems consist of a cranking battery for each engine and additional batteries that supply auxiliary power to DC electrical circuits.

Battery switches control battery power distribution and disconnect the batteries from the boat's electrical system. The engine's charging system charges batteries connected to the charging system when the engines are running.

Battery isolators prevent accessory loads and other batteries from depleting power from charged batteries. Isolators also allow the engine's charging system to isolate the alternator charging output and distribute the charge among all batteries according to individual need.

The main DC control panel may feature a voltmeter, battery test switch, fuses, circuit breakers and a master breaker switch.

The following optional NOCO Onboard Charging Systems (GENPRO10X1, GENPRO10X2, and GENPRO10X) may be installed in the factory or as an available option. See *NOCO Owner's Manual* for more information.

NOTICE *Refer to Starting section under Getting Underway of Barletta Boat's Owner's Manual for more information.*

 **WARNING** *Fire Hazard: Never reset a breaker that has been automatically tripped or replace a fuse that has blown without first identifying and correcting the cause of the problem. A fire could result.*

 **WARNING** *Fire Hazard: DO NOT exceed the recommended fuse sizes or bypass the fuse safeguard. Always install the proper (type and rating) fuses whenever replacing or changing fuses.*

FUEL SYSTEM

The basic fuel systems consist of one or more fuel tanks, tank vents, level sensor and gauge, lines, pumps and valves.

Each tank has an antisiphon valve to prevent fuel from leaking out of the tank should a break occur in the system at a point other than the tank. Refer to the boat and *Engine Operator's Manual* for specific fuel system information and service information.

 **WARNING** *High Speed (Yacht) fuel pumps found at some marinas fill at a much higher rate. Our fuel tanks are designed to fill at a standard automotive type of pump, which fuels at 8-10 GPM. It is important not to overfill the tank when filling. Do not try to force more fuel in past the point of automatic shut-off.*

STEERING SYSTEM

⚠ WARNING *Control Hazard: Be sure to inspect the outboard's steering system for damage after striking an underwater object. Stop immediately to inspect for damage that may result in loss of steering control.*

⚠ WARNING *Control Hazard: Improper maintenance of steering system is hazardous and can cause death or serious injury from sudden loss of control. Ensure all steering hardware, cables and grease fittings are regularly inspected and maintained. If any steering problems are noticed, do not operate the boat and contact your dealer immediately for service assistance.*

The boat may be equipped with one of four different steering systems; mechanical, hydraulic, electric, or electronic. Check steering for smooth operation before each use; if the steering is difficult or binding, do not operate the boat.

MECHANICAL STEERING

This system uses a push-pull cable connected between the steering wheel and the steering link. Some propulsion units provide a connection for hydraulic assist.

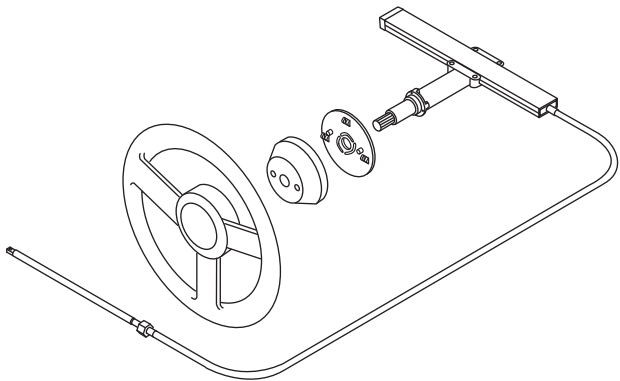

KC-0268-A

Boat steering controls are not self-centering. Always keep a secure grip on the steering wheel to maintain full boat control.

Mechanical steering helm controls transfer the rotary motion of the steering wheel to linear cable motion, which pushes or pulls the engine's steering arm. Some boats are equipped with two mechanical cables to provide positive steering control and additional safety in case one cable fails.

HYDRAULIC STEERING

The boat may be equipped with optional hydraulic steering for easier control of higher horsepower outboards. This system uses a pump built into the steering wheel and hoses connected between the pump and a cylinder attached to the outboard steering link. Turning the wheel pumps hydraulic fluid to the cylinder to turn the engine.

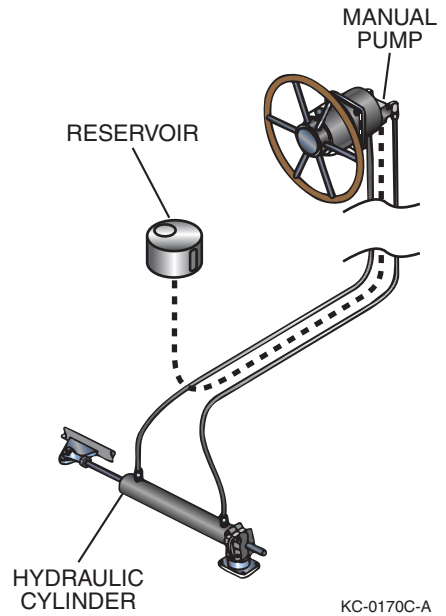

POWER ASSIST STEERING

Much like the hydraulic system, the Power Assist steering system uses a pump and hoses to pump fluid to the steering cylinder, but instead of manually pumping it through the steering helm, there is an electrohydraulic pump that provides increased pressure and ease of operation.

ELECTRIC POWER ASSIST STEERING

Twin engine model boats may be equipped with optional electrical steering for easier control of the most powerful outboards and twin installations. Sensors in this system's steering wheel send signals to an electric motor connected to the outboard steering link to turn the engine. Some electric steering systems are integrated into the outboard engine. See the *Engine Operator's Manual* or steering manufacturer's information for safety and maintenance instructions.



PROPELLERS

The following basic information may not apply to all forms of propulsion. See the *Engine Operator's Manual* for information on propellers for the boat. Consult the boat dealer for assistance when replacing or servicing propellers.

The propeller converts the engine's power into the thrust needed to propel the boat. Care and selection of the propeller is very important for proper boat operation. Propeller size is usually identified by two numbers, such as 13 x 19, and a material identification, such as aluminum or stainless steel. In the number sequence, the first number is the diameter of the propeller in inches and the second is the pitch in inches.

Pitch is the angle of the blades expressed in the theoretical distance a propeller travels in each revolution. In the previous example, the pitch is 19, which means that each revolution of the propeller pushes the boat 19 inches (483 mm) through the water.

Propellers are usually replaced out of the water to prevent loss of parts and to ensure correct installation. Although propeller replacement can be completed with the boat in the water, it is not recommended. Special tools are required for most applications. Always consult the boat dealer for assistance when replacing or servicing propellers.

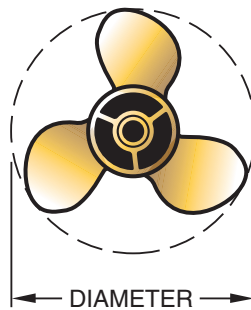

KC-0149C-A

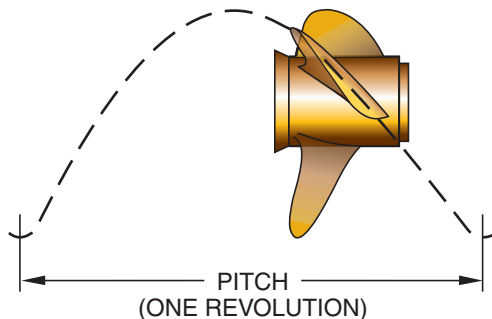

KC-0150C-A

PROPELLER SELECTION AND REPLACEMENT GUIDELINES

There are many different propeller designs for specific operating characteristics. Always consult a certified marine technician when replacing your propeller.

To prevent accidental start-up, complete the following before installing or removing the propeller:

- Position the shift control in NEUTRAL.
- Position the battery switch to the OFF position and remove the key.
- Place a wood block between the cavitation plate and the propeller to hold the propeller in place. Remove the propeller nut.

⚠ WARNING *Personal Injury Hazard: Never use your hand to hold the propeller when removing the propeller nut; the propeller blades are sharp. Wear protective gloves.*

GAUGES / INSTRUMENTS

The following basic and typical information may not apply to your specific boat. This section may not cover all gauges on the boat. See the *Engine Operator's Manual* or equipment manufacturer's supplied information on the use and operation of the unique gauges and instruments.

Gauges are visual indicators that help you monitor various system and component operation parameters. Gauges usually have lights integrated into them for visual clarity when operating at night. They are located near the helm area or other main control areas. Gauges are available in two forms, digital and analog. No matter the form, most modern gauges connect to the NMEA 2K or CANBUS network to receive the information to display.

MULTI-GAUGES

The boat may be equipped with one or more multi-gauges that combine an analog look with digital display of specific data such as fuel management/economy, trip logs and GPS and is speed-selectable with the touch of a button. Some multi-gauges allow boaters to customize the type of information and how it is displayed. These gauges communicate digitally over an NMEA 2K or CANBUS network and replace mechanical gauges, sensors and wires. Most units support multiple propulsion units and share data with other operation stations. Refer to the *Gauge and Propulsion Manufacturer's Owner's Manual* for more information.



FUEL LEVEL GAUGE

The fuel level gauge indicates approximate fuel level in the fuel tank via an in-tank sensor. The accuracy of the fuel gauge may vary as the attitude of the boat changes; the reading is only an approximation. As a general rule, always use the “one third” rule. Use one third of the fuel to reach your destination, one third to return and one third as reserve fuel.

ACCESSORY PORTS

Your boat may be equipped with one or more accessory power ports for electronics. Ports may be a round 12VDC “cigarette lighter” style and/or 5VDC USB style. These ports are for power/charging only and are typically active when the battery switch is ON.

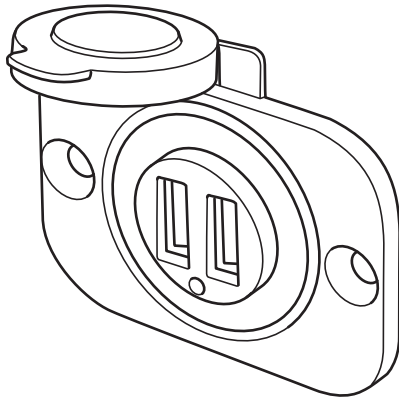

USB ports cannot be used for uploading/downloading data or music and are typically limited to 2A draw. The ports are protected by a circuit breaker or may have an inline fuse.

HELM AND CONTROL SWITCHES

The following information is intended as basic and typical and may not apply to your specific application. Not all switches may be covered in this section. See the *Manufacturer’s Operator’s Manual* for specific information on the use and operation of switches in the boat.

Many of the electrical features and systems in the boat are equipped with a control switch and protected with breakers or fuses. Switches are designed for different applications and found in many styles and shapes. Some switches may have a lighted indicator for easy ON/OFF identification. Some switch panels contain a master power switch that controls power to all circuits.

BATTERY SWITCH

Battery switches are used to control battery power distribution and disconnect the batteries from the boat’s electrical system. Battery switches are designed in many styles and for different applications. They generally provide battery isolation when used with

multiple batteries and are used primarily as a method of quick and positive battery disconnection. Battery switches also protect against tampering, electrical fire hazards and battery drain. Keep this switch off when not using the boat or when storing it for extended periods of time. More sophisticated DC electrical systems may be equipped with remote operated switches that are activated by a switch at the helm or DC distribution panel.

NOTICE

Do not turn off the battery switch with the engine running; this could damage the engine’s charging system.

Consult a qualified, knowledgeable technician for proper operation of the boat’s specific electrical system.

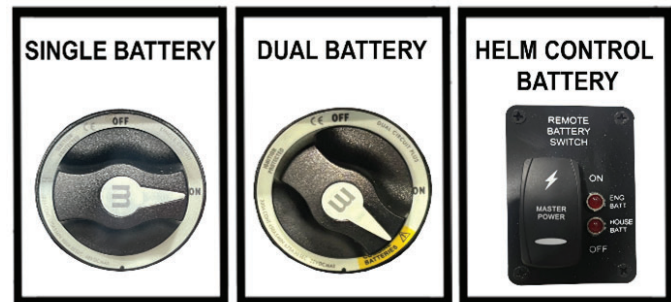

TYPICAL BATTERY SWITCHES

OFF Position - Neither of the batteries are connected to the engine’s starting or charging systems except the “always on” bilge pump. The switch should be in the OFF position when the boat is not being used to ensure that the batteries do not lose their charge. The switch should also be in the OFF position when an external battery charger is being used to charge the battery(s) to avoid possible damage to the electronic components on the engine or in the boat.

NOTICE

Do not turn the battery switch to any other position with the engine running; this could damage the engine’s charging system.

“1” Position - This is usually the main battery. Normally when the battery switch is not OFF, it should be set on 1.

“Combined” Position - This position would be used in an emergency situation where one or both batteries are low and power is needed from both batteries to start the engine. Once the engine has started, put the battery switch in “On” position (but not OFF) to direct all of the charging current to batteries.

NOTICE *If the battery is dead or severely undercharged, do not use the engine charging system's alternator to bring the battery to a fully charged condition. The excessive current draw can overheat the alternator and cause it to fail. If you have a dead battery, use an external battery charger to bring the battery to a fully charged condition.*

EASY DOCK THRUSTER SYSTEM

Designed to make docking and maneuvering significantly easier, especially in tight spaces or challenging conditions, the Easy Dock Thruster System is controlled via intuitive buttons at the helm, allowing for precise control of the boat's movements. The thruster switch panel, located on the left side of the steering wheel, includes bow and stern thrusters that can move the boat sideways or pivot it in place.

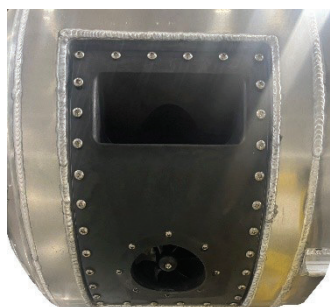

Only available on Reserve, Reserve Leggera and Lusso models.



- 1. System Power and Reverse Flush
- 2. Bow Thruster Port and Starboard
- 3. Stern Thruster Port and Starboard

NOTICE *Refer to Thruster owner's manual for operation.*

FUEL BURNING APPLIANCES

⚠ DANGER *Exhaust Hazard! Fuel-burning open-flame appliances consume cabin oxygen and release products of combustion into the boat. Ventilation is required when appliances are in use. Open designated vent openings while appliances are in use. Never obstruct ventilation openings and ensure that fluid appliances are operating correctly.*

If your boat is equipped with a liquefied petroleum gas (LPG) appliance such as a grill, be sure to read and understand the *Appliance's Owner's Manual* information and follow the appliance's safety labels before operating the appliance. Fuel-burning or open-flame appliances consume cabin oxygen and release products of combustion in the craft. Ventilation is required when operating or changing fuel cylinders for these types of appliances. Make sure there is adequate ventilation, and the appliance is working correctly. DO NOT use these types of appliances to heat the galley or cabin spaces.

If your boat is equipped with a fuel-burning appliance:

- The use of fuel produces carbon monoxide gas. Be sure spaces containing fuel-burning appliances are well-ventilated.
- Do not obstruct access to the appliance in any way.
- At least annually, inspect the hose and vent of the appliance. Replace if any deterioration is found.
- Keep valves on empty cylinders closed and disconnected. Keep protective covers, caps or plugs in place. Store reserve or empty cylinders in approved storage lockers or housings which are vented to the outside and intended for that purpose or on the boat exterior, protected from the weather and mechanical damage, and where escaping vapors can only flow overboard.
- Never use fuel storage housings or cylinder lockers to store any other equipment.



GENERAL OPERATION OF FUEL-BURNING APPLIANCES

IMPORTANT– Refer to the *Appliance's Owner's Manual* for specific operation.

Close LPG supply line valves and cylinder valves when not using appliances, before refueling and immediately in an emergency.

Close appliance valves before opening the cylinder valve.

Open designated vent and openings while appliances are in use. Never obstruct ventilation openings.

If the stove is not gimballed, do not use it when you expect the likelihood of high angles of rolling or sustained angles of heel.

! WARNING *Fire/Explosion Hazard: Do not use an LPG installation that has leaked until it has been inspected and repaired by a competent person.*

If you detect or suspect LPG leakage, take the following action immediately:

- Shut off the LPG supply at the main supply valve(s).
- Extinguish naked flames and other ignition sources (heaters, cooking appliances, pilot lights, etc.).
- Do not operate electric switches.
- Evacuate the area if possible.

PROPANE GAS GRILL

! WARNING *Personal Injury Hazard: Take special care when using a propane gas grill on a boat. Failure to take proper precautions may cause personal injury or property damage.*

Some models may be equipped with an optional propane gas grill. Only use the grill when it is in the grill mount. Leave the grill in the grill mount until it is completely cool to the touch. For further information, refer to your gas grill owner's manual.

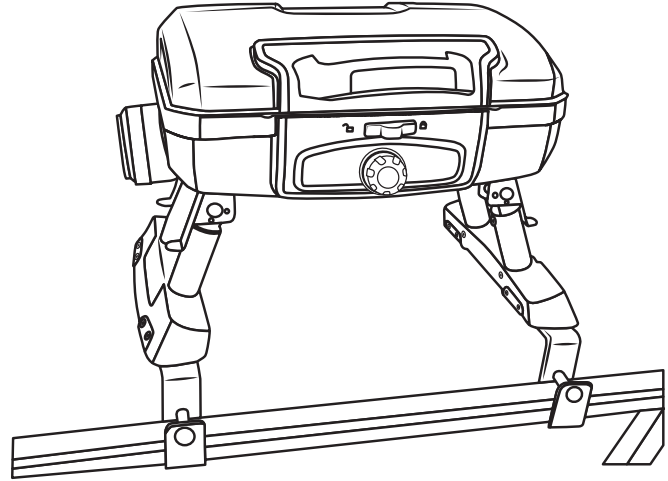

KCB-0116

To Use the Grill:

1. Set up the gas grill in a location that offers the best protection from the wind.
2. Do not attempt to use the grill while the boat is moving.
3. Do not allow combustible materials near the grill.
4. Ensure that the grill has cooled completely before removing it for storage.
5. If in a marina, check the marina's rules and regulations for the use of grills.

FISHING MODELS

Depending on the boat model, fishing models may be equipped with a livewell, fishing seats and a trolling motor receptacle and plug to enhance fishability.

LIVEWELLS

Livewells are designed to help protect and keep fish or bait alive and can only be used when the boat is in the water. Always use clean fresh water. Empty and thoroughly dry the livewell after each use to prevent contaminating the fish and prevent the transport of AIS. Never use soap, detergents or other cleaners that may be harmful to fish to clean the livewell.

NOTICE *To avoid freeze damage to the livewell system, be sure it is completely empty in freezing weather. Residual water in the system may freeze and cause damage to components.*



This system maintains water in the livewell tank by the use of a pump that recirculates fresh lake water into the tank with a spray nozzle. An overflow tube at the bottom of the tank prevents overflowing. When the water level reaches the top of the overflow tube it empties back into the lake. The overflow tube is also the drain plug. When it is removed the water will drain.

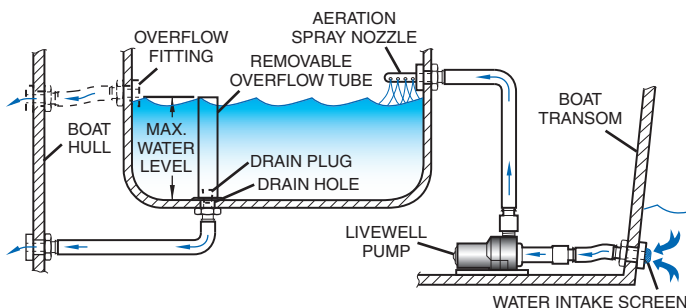

NOTICE

Don't forget that using the aerator pump over a period of time with the engine shut down will drain your battery.

Check the livewell pump often to make sure it is operating efficiently. The pump is located at the rear of the boat and can be accessed through the plates in the splash well or engine compartment. Remove debris and rinse bilge with fresh water with the pump running.

FISHING SEATS

Some models may be equipped with optional pedestal fishing seats. These seats are mounted on swivel posts. To mount, slide the pedestal post into the base then slide the seat into the post. Pedestal seats in the bow area can restrict the driver's view and must be removed when underway at speeds other than trolling.

⚠ WARNING *Man Overboard Hazard: DO NOT sit in pedestal seats while underway except at trolling speeds. You risk being thrown overboard.*

BARLETTA COASTAL EDITION

The Barletta Coastal Edition is specifically engineered for saltwater environments, offering enhanced durability, corrosion resistance, and performance for coastal and intercoastal boating.

CORROSION PROTECTION AND DURABILITY

- **Metal Jacket Protectant:** Applied to toons, underbelly skin, and all above-deck stainless steel, providing an extra barrier against saltwater damage.
- **Sacrificial Zinc Anode:** A softer metal component that attracts galvanic corrosion, protecting critical parts like the engine by acting as a decoy.
- **Sealed Lifting Strakes:** Prevent saltwater intrusion and marine life buildup, reducing corrosion and foul odors.

SALTWATER READY CONSTRUCTION

- **Aluminum Components:** All seat bases, armrests, and springs are made from aluminum instead of steel to prevent rust.
- **Fiberglass Center Console:** Built to handle rough, open water and saltwater conditions.
- **Aluminum Hull:** Naturally resistant to rust, though still susceptible to galvanic corrosion, which is mitigated through design and maintenance.



SECTION
8

BOAT FEATURES AND OPTIONS

PERFORMANCE AND VERSATILITY

- Triple Toon Design & High Profiles: Offers stability and power for intercoastal cruising, island beaching, and various saltwater adventures (excluding offshore boating).
- Large Engines: Optimized for performance in coastal waters.

MAINTENANCE AND LONGEVITY

- **Regular Freshwater Rinsing:** Essential to prevent salt buildup and corrosion.

NOTICE *If boat is not routinely rinsed, corrosion is not covered under the Barletta manufacturer warranty.*

- **Engine Flushing & Service:** Routine maintenance ensures smooth operation and longevity in saltwater use.

AESTHETIC AND BRANDING

Coastal Edition Badging: Distinctive branding to signify the boat's saltwater-ready build and premium features.

POWER BIMINI TOP INSTRUCTIONS FOR PROPER OPERATION

NOTICE

- *ALWAYS* have the protective boot installed, except for the FULL OPEN position.
- *ALWAYS* remain on the UP/DOWN button until the unit turns itself off.
- *ALWAYS* store the PWR ARM in the Full Down position with the boot on when not in use.

WARNING

- **NEVER attempt to operate the top while the boat is in motion.**
- **NEVER exceed 25 MPH without the boot properly installed.**
- **NEVER open the top in excessively high winds.**
- **NEVER trailer the boat without the boot on in the full down position.**
- **NEVER open the top without the canvas installed - actuator damage may result.**



FULL OPEN POSITION – MAXIMUM SHADE

Proper Operation

1. Remove protective boot
2. Depress and hold UP button on helm until motors turn off on their own – **do not release button until motors turn off**
3. Speed Limit in this position 25 MPH
4. Do not open in excessively high winds



VARI-PITCH POSITION – SHADE DURING LOW SUN

Proper Operation

1. Remove protective boot
2. Depress and hold UP/DOWN button on helm until desired position is reached and then release button
3. Speed Limit in this position 5 MPH
4. Do not open in excessively high winds



RADAR POSITION – REAR ENTRY/EXIT

Proper Operation

1. Install protective boot
2. Depress and hold UP button on helm until motors turn off on their own - do not release button until motors turn off
3. Speed Limit in this position 50 MPH



FULL DOWN POSITION – LIFTS/BRIDGES/STORAGE

Proper Operation

1. Install protective boot for storage and road travel
2. Depress and hold DOWN button on helm until motors turn off on their own
3. Speed Limit with boot installed 65 MPH
4. Speed Limit without boot installed 5 MPH



ARCH OPERATION

⚠ WARNING Please ensure that two people lower the arch. Person 1 should release the arch, and person 2 should stand next to the helm with both hands on the arch while it's being released. Then, slowly lower the arch into the down position.

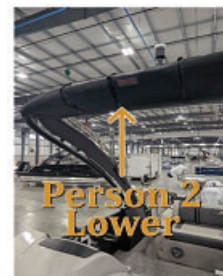

JBL POWERED RALLYBAR OPTION AND OPERATION

⚠ WARNING Due to the weight of the sport arch with optional JBL soundbar, the arch may lower faster than expected.

BIMINI OPTIONS

Standard Bimini





Double Bimini



Lusso Arch



Sport Bimini



BIMINI BOOT































The Bimini protective boot is used to cover and protect the Bimini top for storage and road travel. It helps prevent damage from elements such as UV rays or precipitation.

Corsa Arch





SYMBOLS

BASE SYMBOLS				
 Boat	 Boat Profile	 Engine	 Tank	 Light
SWITCH SYMBOLS				
 Interior Light	 Anchor Light	 Navigation Light	 Engine Room Blower	 Bilge Pump
 Windlass	 Depth Finder	 Windshield Wiper	 Windshield Washer	 Horn
ENGINE SYMBOLS				
 Ignition	 Hour Meter	 Engine Key	 Engine Stop	 Engine Alert
TANK & BATTERY SYMBOLS				
 Fuel	 Waste Holding	 Freshwater	 Battery	 Battery Parallel
OTHER SYMBOLS				
 Sling Point	 Lift Point	 Fuel	 Diesel Fuel	 Safety Alert



SECTION
8

BOAT FEATURES AND OPTIONS

This Page Intentionally Left Blank

Section 9

OPERATING THE BOAT

Before operating the boat, review *Safety in Section 2*.

 **WARNING** *Control Hazard: Certain actions can cause you to lose control of the boat:*

- ***When accelerating the boat in the forward direction, the bow can rise and restrict visibility. Observe for obstacles and people before accelerating.***
- ***The rotational thrust of the propeller under rapid acceleration can create high steering torque and rapidly change the direction of steering, causing loss of control.***
- ***Do not trim the engine out too far or the boat may begin to “porpoise” (bounce up and down). Porpoising reduces control and visibility.***
- ***Improper use of trim tabs or moving them down at high speeds can cause loss of control.***
- ***If you lose control of the boat, pull back on the throttle and trim in at the same time.***

BEFORE GETTING UNDERWAY

SAFETY EQUIPMENT

Federal and local laws require certain safety equipment to be on board at all times. Responsible boaters carry additional equipment in case of emergency.

FLOAT PLAN

Complete a float plan before departure and leave it with a reliable person who is aware of your intentions while on the water. In case of emergency or if you do not return as planned, this information can be helpful to the USCG or others in rescuing or contacting you. There are several float plan apps that make it easy to fill out and email the plan. For more information on float plans or to download a float plan form, go to:

<https://www.floatplancentral.cgaux.org>

PRE-DEPARTURE SAFETY CHECKLIST

The following checks are essential to safe boating and must be performed before starting the engine or getting underway. Perform these checks every time you operate the boat so they become routine.

Never launch the boat or leave the safety of the dock if any problem is found during the pre-departure safety check. A problem could lead to an accident during the outing, causing severe injury or death. Have any problems corrected before proceeding:

- Check the current and forecasted weather reports, as well as wind and water conditions.
- Make sure the operator is qualified to operate the boat and does not use drugs or alcohol while at the helm.
- Make sure all required safety equipment is on board.
- Make all passengers aware of safety procedures.
- File a float plan.
- Have all required documents on board.
- Have all maps or navigational charts for the intended destination on board.
- Be sure all passengers are properly seated.
- Be sure the boat is not overloaded.
- Check the engine cut-off switch lanyard for proper installation and operation.
- Be sure the fire extinguisher is fully charged.
- Check bilge drain plugs for proper installation.
- Be sure all water has been pumped from the bilge area.
- Have plenty of emergency food and water on board.
- Check the bilge blower (if equipped) for proper operation, and be sure no fumes are present in the bilge area.
- Be sure all required equipment is on board (mooring lines, anchor lines, tool kit, etc.).
- Be sure you have enough fuel for the return trip.
- Check all compartments for fuel fumes.
- Check that no fuel, oil or water is leaking or has leaked into the bilge compartment.
- Check all hoses and connections for leakage and damage.
- Check the hull and propeller for damage.
- Check the engine cooling water intake pickup for blockage.
- Check that batteries are fully charged and the battery terminals are clean and tight.



- Check the electrical systems and navigation lights for proper operation.
- Be sure no person or obstacle is near the propeller.
- Check that the throttle/shift control is in the NEUTRAL position.
- Check the steering system for proper operation.
- Inspect the steering, throttle and shift cables for kinks, wear and interference with other components.
- Check that all required maintenance has been performed.

BOARDING

Helpful guidelines when boarding a boat:

- Always step, rather than jump, into a boat.
- Avoid stepping on fiberglass or other potentially slippery surfaces.
- Always board one person at a time.
- Never board while carrying gear. Set the gear on the dock, board the boat and then pick up the gear.
- Never use the engine unit as a boarding ramp.
- It is courteous to always ask for permission to board so the owner/operator is aware of your presence on the boat.
- Always face the boat when boarding/re-boarding using a ladder.

WARNING

- **PERSONAL INJURY HAZARD – Stay alert. Use of drugs, alcohol or other substances which impair judgment poses a serious threat to yourself and others. The boat operator is responsible for the behavior of passengers.**
- **DROWNING HAZARD – Boats must carry one USCG approved properly sized, wearable personal flotation device (PFD) for every person on board. Boats must also have at least one throwable life preserver.**
- **SLIPPING HAZARD – Wet decks are slippery. Wear proper footwear and use extreme caution on wet surfaces.**

USING THE BOARDING LADDERS

Every Barletta boat is equipped with a ladder when it leaves the factory. The ladders are designed so a person can deploy it while onboard and get into and out of the water safely. Ladders are usually located on the starboard side, however, some boats have a ladder on the port side. Your boat can be equipped with one of two ladders: an aluminum stair step ladder or a stainless-steel ladder.



WARNING *Personal Injury Hazard: Always turn the engine off whenever anyone is in the water near the boat.*

Boarding Ladder Precautions:

- NEVER allow anyone in the water near the boarding ladder while the engine is running
- ALWAYS be sure the ladder is fully retracted and secured after use, before operating the boat

To deploy the ladder; stand on the aft deck and unhook the strap and slowly release into the water. To stow the ladder after use, grab the strap and pull back in towards the boat. Secure in place by attaching the strap to the ladder handles.



BOAT LOADING

The safety and performance of the boat depends on load, weight and the distribution of each.

The person/load capacity is determined by the USCG. A capacity plate is usually located within clear visibility of the boat operator or helm area. The capacity plate indicates limits for loading the boat, which are enforceable by law.

NOTICE

60% of people should be seated in the AFT while underway. ESPECIALLY under rough conditions.

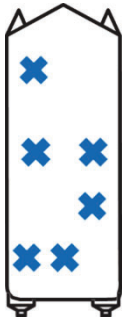
PROPER
DISTRIBUTIONPROPER
DISTRIBUTIONIMPROPER
DISTRIBUTION

(BOW HEAVY)

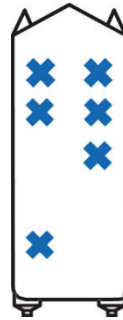
IMPROPER
DISTRIBUTIONIMPROPER
DISTRIBUTION
(STARBOARD HEAVY)

⚠ WARNING *Sinking Hazard: NEVER exceed the USCG certified maximum capacities under any circumstances. Exceeding the limitations stated on the capacity plate can cause the boat to sink or the passengers and/or operator to drown, resulting in death or serious injury.*

- Board passengers one at a time and distribute them equally to maintain equal buoyancy of the boat.
- Distribute weight equally from port to starboard and fore to aft. The shifting of weight may be required when underway to maintain an efficient trim position for optimum performance.
- Stow and secure all loose gear in stowage areas to prevent load shifting.
- Do not stow gear on top of safety equipment; safety equipment must be quickly accessible.
- In adverse weather, reduce the load in the boat. Person and load capacity ratings are calculated for normal boating conditions.
- Do not allow passengers to obstruct the captain's line of sight during operation.

FUELING

FUEL MANAGEMENT

Use the “one-third” rule for fuel management. Use one-third of the fuel to reach your destination, one-third to return and one-third as reserve fuel.

FUEL SUPPLIERS

Refuel only at approved suppliers such as marina fuel docks or automotive fuel service stations. Approved suppliers have safeguards in place to lessen the likelihood of static discharge. Use only containers and funnels approved for use with the fuel type. See the *Before Refueling* section of this manual for additional information.

STATIC ELECTRICITY AND THE FUEL SYSTEM

The boat's built-in fuel tank has a bonding system that protects it from creating and discharging static electricity. The boat must be in contact with the water or on its trailer when refueling to complete the bonding system.

If the bonding system is not complete, an electrostatic spark may occur.

⚠ WARNING *Fire/Explosion Hazard: An electrostatic spark can ignite fuel vapors, causing a fire and/or explosion.*

⚠ WARNING *Do not use built-in style locking gas caps as they are not properly vented and can cause boat to stall and engine damage.*



SECTION
9

OPERATING THE BOAT

Use extreme caution when filling the fuel system. In addition:

- Do not refuel a built-in fuel tank if the boat is suspended from a sling or another type of boat lift system. Suspending the boat from the water interrupts its bonding system. Using a portable fuel tank to refuel the boat while it is suspended may cause an electrostatic spark.

FUEL (GASOLINE)

Fuel for marine gasoline-only engines must be carefully selected to avoid fines and possible catastrophic engine damage not covered under warranty. It is illegal for any person to tamper with emissions control devices such as the fuel system, and it is also illegal for any person to mis-fuel a marine gasoline-only engine with a blend of more than 10% ethanol.



While it is always preferable to use fuel that does not contain ethanol (usually labeled as “marine” or “recreational”),



most marine engines are designed to tolerate E10 (10% maximum ethanol) fuel as long as the fuel meets the engine manufacturer’s octane requirements. When using fuel containing ethanol, buy fuel in smaller quantities that will be consumed during the boating session with a 10% reserve. Fuel degrades quickly and the engine operates better on fresh fuel. Use marine fuel stabilizer to treat and reduce degradation of any remaining fuel.

Fuels that contain bio-isobutanol at any percentage are safe to use in marine products and have none of the limitations of ethanol biofuel additives.

Do not use octane boosters or other fuel additives except marine certified fuel stabilizer. Purchase fuel from a quality supplier selling high volumes to ensure the fuel is fresh. For more information go to: www.toptiergas.com/licensed-brands/

NOTICE

Fuels that are blended to contain more than 10% ethanol may damage the engine, oil system or fuel system and should not be used in marine engines. Fuels that contain more than 10% ethanol can corrode metal parts, deteriorate rubber and plastic, or weaken gaskets. Damages caused by the use of fuels that contain more than 10% ethanol or fuels that do not meet engine manufacturer octane requirements are not covered by your warranty.

Gasoline Fuel in the U.S. Market

The majority of recreational boats are trailerable and often fueled at automobile gasoline filling stations. In the U.S. market, there are ever-increasing percentages of ethanol blended with gasoline with the most common being 10%. Since there is no standard for labeling gas pumps, it can be confusing to select the proper blend – LOOK BEFORE YOU PUMP!

Ethanol blends of more than 10% are tempting to use in your boat because they are cheaper. Ethanol blends of more than 10% are NOT meant for ANY outdoor power equipment and their illegal use will not only deteriorate rubber and plastic, causing an environmental hazard, but will cause permanent DAMAGE to the engine that is not covered by the Warranty – DO NOT BUY GAS BY PRICE!



	CONTAINS NO ETHANOL	UP TO 10% ETHANOL	UP TO 15% ETHANOL	UP TO 30% ETHANOL	UP TO 50% ETHANOL	UP TO 85% ETHANOL
OK for Boat Engines	Yes	Yes**	No	No	No	No
OK for Long-Term Storage	Yes*	No	No	No	No	No
Covered by Engine Warranty	Yes	Yes	No	No	No	No
Illegal to Use in Boat Engines	No	No	Yes	Yes	Yes	Yes
Price	Most Expensive	About 5% less	About 10% less	About 20% less	About 30% less	Least Expensive

* 3 – 6 months with marine-grade fuel stabilizer *added immediately*

** Not more than one month with marine certified marine-grade fuel stabilizer *added immediately*

BEFORE REFUELING

⚠ WARNING *Fire/Explosion Hazard: Gasoline is extremely flammable and highly explosive under certain conditions. Be sure to check the fuel hoses and connectors for leaking and deterioration before fueling and on a monthly basis.*

- Refuel the tanks only in a well-lighted area.
- Know where the fire extinguishers are.
- Stop all engines, motors, blowers and appliances before refueling.
- Do not smoke or allow open flames or sparks nearby, within 50 feet (15 meters), of the fueling area.
- If equipped, close all doors, windows, hatches and ports.
- Determine the amount of fuel required to fill the tanks. Fuel expands as the ambient temperature increases; do not overfill the fuel tank. Allow for at least a 6% expansion of fuel when refueling.

REFUELING

The fuel filler on boats with built-in tanks is usually located on the gunwale or aft area. The fuel tank is equipped with either a shutoff valve or antisiphon valve. The shutoff valve requires you to manually turn the fuel valve, while the antisiphon valve operates automatically. Because gasoline fumes are heavier than air, they will sink to the lowest part of your boat, such as the bilge.

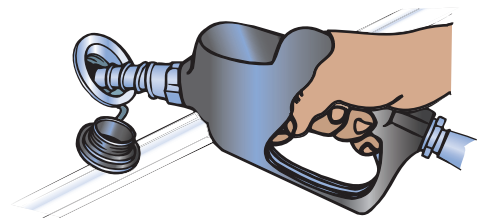

KC-0027C-A

NOTICE *To prevent unwarranted engine damage, refer to the Engine Operator’s Manual for recommended fuel and oil specifications.*

⚠ CAUTION *The fuel tank may be under pressure. Remove fuel filler cap slowly to release any pressure.*

⚠ WARNING *Do not use built-in style locking gas caps as they are not properly vented and can cause boat to stall and engine damage.*

NOTICE *High Speed (Yacht) fuel pumps found at some marinas fill at a much higher rate. Our fuel tanks are designed to fill at a standard automotive type of pump, which fuels at 8-10 GPM. It is important not to overfill the tank when filling. Do not try to force more fuel in past the point of automatic shut-off.*



REFUELING BUILT-IN FUEL TANKS

When refilling a permanent fuel tank from a land-based fuel nozzle with the boat out of the water, maintain contact between the fuel nozzle and the fill pipe at all times, before and during refueling, to prevent an electrostatic spark. If it's necessary to use a funnel, use a metal funnel. Do not use a plastic funnel. Do not fill built-in tanks from unapproved portable containers.

When refilling a permanent fuel tank from an approved portable fuel container with the boat in the water, a plastic funnel may be used.

NOTICE

If the boat is unlikely to be used for two weeks or more, and you are using an ethanol-blended fuel, fill only the amount of fuel you need plus 10% as a safety factor. Unused ethanol-blended fuel deteriorates quickly.

AFTER REFUELING

- Close the fuel fill cap thoroughly.
- Wipe up any spilled fuel completely. Dispose of rags properly onshore.
- Open all doors, windows, hatches and ports to ventilate all spaces. Check for fuel vapors before starting any engines or appliances.
- If equipped, operate the blower for a minimum of four minutes before starting the engine.

GETTING UNDERWAY

The following basic boat maneuvering and operation principles do not cover all conditions or situations you may encounter during operation. It is important for you and anyone else operating the boat to have certified instruction before operating the boat.

Always advise all passengers on board of your steering, stopping and accelerating intentions. Brief passengers on:

- Obeying captain's orders
- Safety equipment location and operation
- Basic boat operation
- Radio operation
- Re-boarding procedure
- Man overboard procedure
- Emergency procedure
- Hazardous weather procedure
- Docking procedure
- Fueling procedure

Be sure all passengers are properly seated in designated seating positions and not riding on the bow, bow pulpit, deck, gunwale or rear sun deck while underway. Passengers must use caution when riding in the bow. Move to the aft passenger seats during rough water operation or if visibility is restricted. Check that any gates, dive doors or hydraulic beach doors are closed, and that platforms and boarding ladders are up and locked in position.

STARTING

The following information is intended as a basic guideline only and may not apply to your specific engine or controls. See the *Engine Operator's Manual* or control manufacturer's information for instructions on starting and operating the engine, adjustments and maintenance.

- Secure the boat to the dock before starting the engine.
- Check that the throttle is in the NEUTRAL position.
- Turn the battery selector switch to the appropriate ON position.

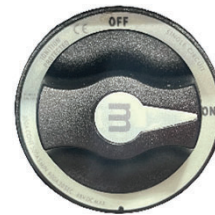

STEERING



WARNING *Control Hazard: If the engine is shut off (no thrust), you will have no steering control, and the boat's momentum will cause it to move forward even though the engine has stopped. Even at low engine speeds where thrust is reduced, a loss of steering control can occur.*

Steering a boat is very different from steering an automobile. Steering and maneuvering a boat is far more difficult and requires time and practice to master.

When steering a boat, it is important to understand the causes and effects of turning. Since both thrust and steering are at the stern of the boat, the stern will push away from the direction the steering wheel (helm) or tiller arm is turned. The boat seems to skid across the water while turning, which feels very different from an automobile making a turn.



Steering in reverse has its own challenges. Practice forward and reverse steering to gain comfort and to feel in control of the boat in any steering situation.

Be prepared for wind and current while steering the boat. Steering in wind or water currents is difficult and requires skill to be able to anticipate and compensate for these effects.

Pontoon boats pose an additional challenge during slow-speed maneuvering in breezy conditions. The combination of light weight and high side-surface area can produce a “sail” effect that pushes the boat around, making docking especially tricky at times. If you feel the boat being pushed adversely when approaching the dock, it may be necessary to “abort” the maneuver and circle around for a different approach.

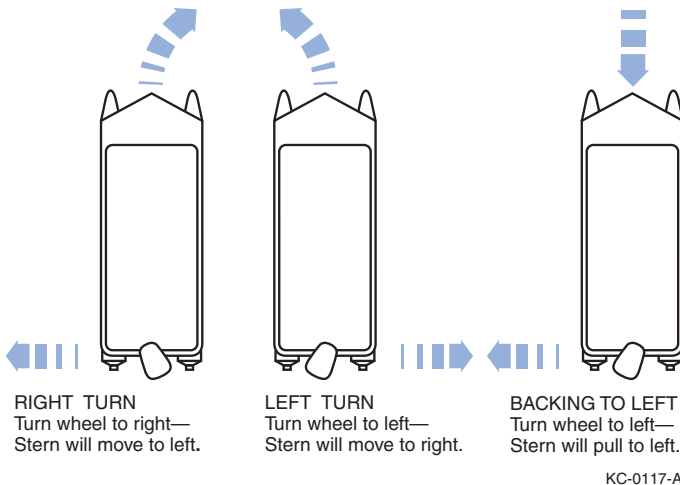

Rotational thrust of the propeller is an aspect most single propeller-driven boats share and needs to be compensated for at slow speeds. During rotational thrust, torque is transmitted to the helm and may cause the boat to drift either port or starboard when moving forward at a slow speed. Rotational thrust usually goes unnoticed at high speeds. While moving forward at a slow speed, constant helm corrections are usually necessary to maintain a straight course.

Twin-engine and dual-prop boats usually compensate for rotational thrust of the propellers by using one counterrotating drive with a counterrotating propeller, and one standard clockwise-rotating drive and propeller to reduce the effects of steering torque at all boat speeds.

SHIFTING

The following information is a basic guideline only and may not apply to the specific shift control. See the *Engine Operator's Manual* or control manufacturer's information for the shift control operation, adjustment and maintenance.

- Most side-mounted throttle and shift controls have a neutral detent lock that must be released before shifting from NEUTRAL.
- Always use a brisk and decisive movement when shifting into or out of gear.
- Always pause in NEUTRAL before shifting from FORWARD to REVERSE, or REVERSE to FORWARD. Most throttle and shift controls have a detent position for NEUTRAL, FORWARD and REVERSE engagement positions. These detent positions are important; when shifting into and out of gear, always pause in these positions.
- Never shift into REVERSE while your boat is in FORWARD gear when traveling at any speed above idle.
- Always keep the shift control clean and clear of obstructions.

STOPPING

Reverse thrust is commonly used to slow and stop a boat. The amount of reverse thrust needed to stop will vary due to boat design, load and speed.

⚠ WARNING *Control Hazard: Always reduce engine speed to idle and pause in NEUTRAL before shifting from FORWARD to REVERSE or REVERSE to FORWARD. Abrupt stopping and steering loss can occur if the propulsion unit is shifted quickly from FORWARD to REVERSE or REVERSE to FORWARD. Never shift into REVERSE at planing or high forward speeds.*

A boat does not have brakes. Controlling the boat to a stop and while stopped are important skills that must be learned. Reverse thrust is commonly used to slow and stop a boat. The continued momentum of a boat will vary according to the boat design, load and speed. You must also consider and learn to compensate for the effects of wind and current. Stopping in wind or water currents is difficult and requires skill to be able to anticipate and compensate for these effects.



- To stop or slow forward motion, always gradually return the throttle(s) to the slow IDLE position, pause and shift into NEUTRAL, then pause and shift into REVERSE.

WARNING *Control Hazard: Gradually return the throttle(s) to the slow IDLE position. Failure to do so can cause loss of boat control and engine propulsion system damage.*

- If the boat has been driven for a long period of time at high speed, allow the engine a two- to three-minute cool-down period at low idle in NEUTRAL.
- Turn the ignition key to the OFF position.

NOTICE *Never pull the lanyard from the engine cut-off switch for normal shutdown. Doing so may impair your ability to restart the engine quickly.*

- Avoid collisions; at high speeds the boat will require more time and distance to stop or slow.
- The proper use of trim tabs and outdrive trim angle is important when slowing to a stop.
- If you are new to boating or before your first outing of the season, practice slowing and stopping in open water. Seek on-water training if needed.

ACCELERATING AND RUNNING UNDERWAY

You must understand the boat's equipment and controls in order to drive and control the boat in a forward direction at all speeds and in all conditions. Learning to drive and control the boat can be challenging; take this matter seriously and spend plenty of time practicing.

The phrase "on plane" is commonly used when referring to the running angle of a boat in forward motion. When a boat is "on plane," its hull is usually running level or almost level with the water's surface, which is considered level. The level "plane" of the water's surface is the most efficient angle to run in. This basically means that the boat is running on top of the water and not plowing through it.

Some pontoon boats with low horsepower engines and/or heavy loads may not be able to reach "plane."

Factors to consider when accelerating a boat forward and running at the most efficient planing angle are:

- Boat design
- Hull type and condition
- Boat load and distribution of weight
- Engine capability and condition
- Propeller type, size and condition
- Outdrive and boat power trim equipment and condition

Because all boats are different and vary in design, purpose and load, planing angles and characteristics will vary among all boats. Become familiar with the boat's characteristics and obtain qualified assistance.

The following guidelines provide a basic understanding of forward acceleration and operating on plane while underway:

- Always look in front of and around you before proceeding. Avoid collisions before accelerating; be aware and stay clear of people and obstacles in the water.
- Always advise all passengers on board of your intention to accelerate and get underway.
- Stow and fasten all loose gear.
- Make sure the engine cut-off switch lanyard is connected to the operator.
- If equipped, adjust the boat trim tabs up or to a neutral position with the hull.
- If equipped, adjust the engine power trim to the full-in position.
- Shift from NEUTRAL into FORWARD detent idle position.
- Adjust steering to the direction of travel.
- Using a controlled and constant motion, move the throttle control forward.

WARNING *Control Hazard: When accelerating forward, the bow can rise and restrict visibility. Never remove your hand from the steering wheel. The rotational thrust of the propeller under rapid acceleration can create high steering torque and rapidly change the direction of steering, causing loss of control.*

- As the boat begins to move, the bow will rise and the boat will tend to plow through the water. As acceleration increases, the boat will begin to plane or level out within a few seconds. If it will not plane to a near-level position and has sufficient horsepower, slowly reduce the throttle back to the FORWARD detent idle position. Recheck the load distribution and trim equipment position to determine the cause.
- Once the boat is on plane, the steering torque will diminish; however, never remove your hands from the helm while underway. While running at a planed position, you will notice greater throttle response and steering control as you continue to accelerate or achieve the most comfortable and safe speed for the conditions. You can achieve better performance, control and running efficiency using the engine's power trim and the boat's trim tabs, if equipped.
- Be aware of the wake you create and anticipate the effect it will have on others. During acceleration, deceleration and at speeds other than on plane, a heavy wake is usually created. You are responsible for the boat's wake and any damage or injury it causes.
- Obey no-wake areas and speed-controlled areas.
- Stay clear of or at a safe distance from other boats.
- Avoid collisions; at high speeds the boat will require more time and distance to stop or slow.

CHECKS AFTER OPERATION

- Check gauges frequently for signs of abnormal conditions.
- Check that controls operate smoothly.
- Check for excessive vibration.

POWER TRIM AND TILT

The following information is a basic guideline only and may not apply to your specific power tilt unit. See the *Engine Operator's Manual* for information on your power tilt operation, adjustment and maintenance.

The engine's power tilt generally operates in conjunction with the power trim system, which is commonly called power trim and tilt. This system allows you to raise and lower the lower drive unit and propeller to adjust trim (the planing and running angle

of the boat while underway) and tilt (used to position the lower drive unit up beyond the power trim range used for trailering, launching or beaching). Never use power tilt while the engine is running.

POWER TRIM

The following information is a basic guideline only and may not apply to your specific power trim unit. See the *Engine Operator's Manual* for information on your power trim operation, adjustment and maintenance.

The engine's power trim allows you to raise and lower the lower drive unit and propeller to adjust the planing and running angle of the boat while underway.

Boat trim adjustment while underway greatly affects boat performance and efficiency. During normal operation while underway at speed, trim the boat to the best possible position to reduce the wetted surface of the hull. With less boat in the water, both speed and fuel economy increase. Adjust systems with manual trim adjustment for best overall operation for the load and conditions. Engines with power trim allow for continuous adjustment for best results.

Adjust the power trim by using a switch at the helm area, multi-function display (MFD), or on the throttle control. Trim gauges are available in most applications to provide a visual gauge-to-trim position. Most gauges indicate trim position between UP (out, away from the transom) and DOWN (in, closer to the transom).

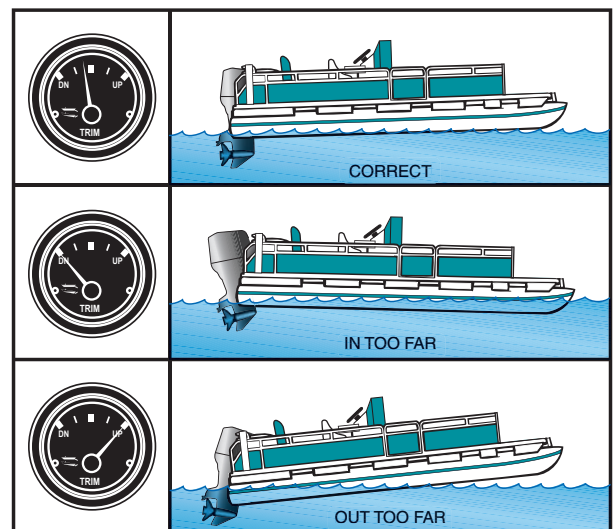

KC-0123C-A

**General effects of power trim underway:**

Trim in too far (closer to the transom):

- Speed decreases.
- Fuel economy decreases.
- Boat may handle and steer poorly.
- Boat will have difficulty achieving a proper running, planing position.

Trim out too far (away from the transom):

- Steering torque increases.
- Speed decreases.
- Fuel economy decreases.
- Boat may handle and steer poorly.
- Boat will bounce or porpoise.
- Engine RPM increases.
- Propeller may ventilate as it nears the surface of the water and slip excessively as it pulls air from the surface. This will cause engine RPM to rapidly rise.
- Boat will have difficulty getting on plane from an idle position.

⚠ WARNING *Control Hazard: Do not trim the engine out too far or you may lose control of the boat. If you lose control of the boat, pull back on the throttle and trim in at the same time.*

See the *Operating the Boat* section of this manual for more details.

General power trim operation guidelines:

- When getting on plane from an idle position, start with the trim full in. As the throttle position increases, the boat speed will increase and drive the bow up. As acceleration proceeds, the bow will start to come down. When the bow starts to fall and the boat begins to plane, slowly start to trim out.
- Trimming out while underway generally causes the boat to rise up and plane. The boat begins accelerating without adjusting the throttle as less of the boat is dragging in the water. Trimming up causes the engine RPM to increase. It is very important to watch the engine tachometer to keep it at or near full throttle operating range and not to exceed the engine's wide-open throttle operation range. See the *Engine Operator's Manual* for the engine's wide-open throttle operation range.

⚠ WARNING *Control Hazard: At speed, do not trim in too far. "Bow steering" (a condition where the bow bites hard into a turn and the stern of the boat violently spins out) may occur when at high speed or under hard throttle.*

- To find the optimum trim position while underway, run the boat at a stable planed angle with the least possible amount of the hull in the water. The boat reaches optimum trim position when it is not porpoising or plowing excess water.

High-speed operation on smooth water provides stability, but you must maintain control by using quick reactions and adjustments. Know your limits and stay within them. Keep one hand on the steering wheel and the other on the throttle controls at all times.

⚠ WARNING *Control Hazard: If you lose control of the boat, pull back on the throttle and trim in at the same time.*

Constant adjustments are necessary for rapidly changing conditions. Small inputs of throttle and steering are exaggerated at high speeds. Depending on the speed, keep watch well ahead so that you have enough time to react.

If the boat has trim tabs, you can achieve further boat trim adjustment by using the trim tabs in conjunction with the engine power trim equipment.

PERFORMANCE OPERATION

Pontoon boats with triple pontoons and deck boats often have high horsepower engines, or twin engines for increased performance. Operators of these boats must exercise additional caution when turning or operating in rough water at high speeds. Practice operation by yourself in open water by gradually increasing speed so you get a feel for the operating characteristics of the boat. Do not take passengers until you are confident of your operating abilities. Inform passengers of your intentions, require they wear a life jacket, sit in designated seats and use any available handholds. Do not make sharp turns or operate too fast for conditions.



DOCKING

Practice leaving and approaching the dock to become familiar with the procedures.

Helpful guidelines when departing from the dock:

- Make sure you have sufficient space to maneuver the boat away from the dock, other boats and any other obstacles that may hinder your departure.
- Always allow sufficient clearance to the stern for the engine to clear any obstructions.
- Be aware of other boat traffic, wind and water conditions before departing.
- Make sure the engine is started and you have boat movement under control before casting off any mooring lines.
- Always proceed slowly when departing from a dock.

Helpful guidelines when docking:

- Make sure you have sufficient space to maneuver your boat around the dock, other boats and any other obstacles that may hinder your approach.
- Be aware of other boat traffic, wind and water conditions on your approach.
- Approach from a direction against the wind or current.
- When possible, approach slowly from a 45-degree angle and then steer parallel to the dock.
- Have fenders, dock lines and assistance ready.
- If your boat has limited visibility from the helm, handheld communicators can be helpful.

Pontoon boats pose an additional challenge during slow-speed maneuvering in breezy conditions. The combination of light weight and high side-surface area can produce a “sail” effect that pushes the boat around, making docking especially tricky at times. If you feel the boat being pushed adversely when approaching the dock, it may be necessary to “abort” the maneuver and circle around for a different approach.

! WARNING *Personal Injury Hazard: Never use your hand, arm or any other part of your body to attempt to keep the boat from hitting the dock. The boat could push against the dock, causing severe injury.*

- If possible, throw a mooring line to a person on the dock and have that person secure the bow. With the bow secure, swing the stern in with the engine or pull it in using a boat hook or the stern line.
- Tie off the bow and then the stern.
- Use bow and stern dock lines, as well as spring lines, for additional security.
- Use fenders to protect the boat from damage.
- Never attach a dock line to a point or part of the boat that is not designed to withstand the stress and the weight of the boat.
- If planning on docking the boat for a long period of time, use chafing protectors on the lines to protect the boat's finish.
- Leave some slack in the lines to allow for wave movement or tidal action if applicable.

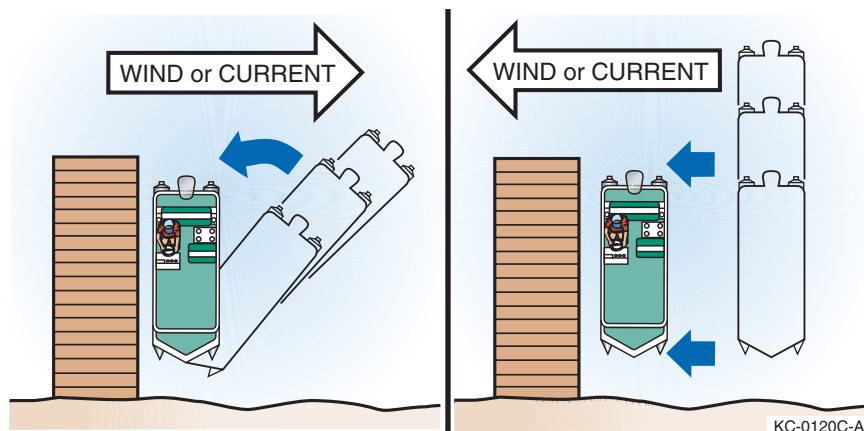



MOORING

Because mooring configurations vary, consult with other experienced boaters or the boat dealer for recommendations on properly mooring the boat. Always moor the boat securely to prevent personal injury or property damage.

Helpful guidelines when mooring:

- Each mooring line must be of the appropriate strength, material and type to safely secure your boat when moored.
- Each mooring line must be longer than the length of the boat.
- Use bow and stern mooring lines, as well as spring lines, for additional security.
- Use fenders to protect the boat from damage.
- When possible, tie up with the bow facing into the wind or current.
- Never attach a mooring line to a point or part of your boat that is not designed to withstand the stress and the weight of the boat.
- Only use the bow eye, stern eyes and other cleats or attachment points that have been approved for mooring. Designated strong points should be used whenever possible.
- If you plan on mooring the boat for a long period of time, use chafing protectors on lines to protect the boat's finish.
- Leave some slack in the lines to allow for wave movement or tidal action if applicable.

COVERING

Use of a mooring cover is highly recommended when the boat is not in use to prevent UV sun damage, mold, mildew, and damage from bird droppings. Depending on your model, there are small variations in covers.

Steps to putting your cover on:

1. Begin by putting your top in the trailering position and putting the bimini boot cover over the canvas.
2. Start at the bow and drape the front portion of the cover over the seats, reach over the rails and snap the clips in place on the rail.
3. Work your way around the boat, clipping the cover onto the rails in the order of the diagram below.
4. As you work your way from bow to stern, deploy the support posts at the designated areas. Make sure to adjust so the cover is taught and allows for sufficient water run off.

5. When you reach the cockpit, there will be Velcro and drawstrings to apply the cover around the bimini frame or arch.
6. When you reach the stern of the boat, take a quick glance and make sure everything is secure. If any poles are lopsided, crawl inside and straighten back up to ensure a taught cover and avoid water pooling.
7. Lastly, secure your bimini in place with the Velcro strap.

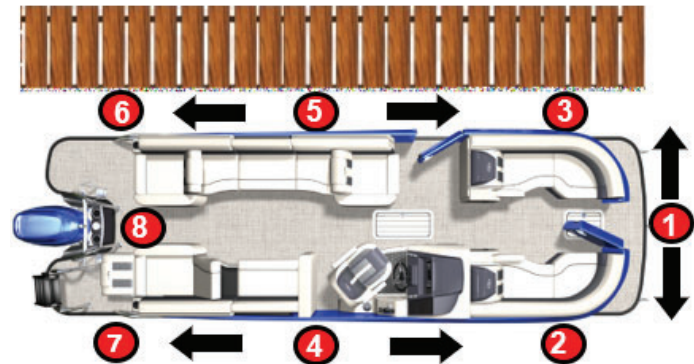

CABANA ENCLOSURES

Some models may be equipped with an optional cabana enclosure. The cabana is designed as a sleeper curtain, but will also provide some protection from the elements. Although the fabric is water-resistant, rainwater can enter at the seams. A tent fabric seam sealer is recommended for further protection. Cabana enclosures can be retrofitted to most models; consult your dealer.

ANCHORS AND ANCHORING

Anchors are available for various applications and come in many sizes, types and shapes. Boat weight and size are primary factors in choosing an anchor. When selecting an anchor, consult other qualified boaters familiar with waters or the boat dealer.

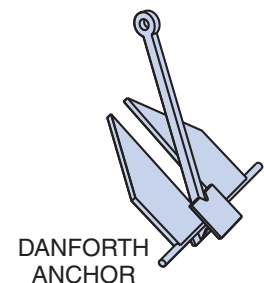

DANFORTH ANCHOR

KC-0042-A

Anchor line is constructed from various materials and is available in many diameters and types; larger craft use chain instead of line. The anchor rode for recreational boats consists of the anchor line connected to a length of chain attached to the anchor. Consult with the boat dealer for a recommendation on appropriate lines for the boat anchor and application.

For most applications, anchor line length should be at least six to seven times longer than the depth of the water in which

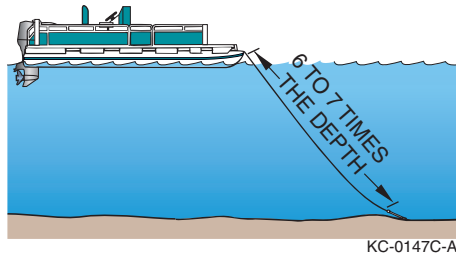

KC-0147C-A

you are anchoring. Always have plenty of additional anchor line on board. If anchoring in tidal waters, consider a rode chain about the length of the boat and increase the total anchor line length to ten times the depth of the water at low tide.

To begin anchoring, make sure that you are facing into the wind and locate which direction the current is coming from. Keep the anchor rode in one hand and throw the anchor into the current so that the boat will naturally float away from the anchor. Let your anchor rode or line out until the anchor has hit the bottom of the seafloor. You will want to leave a small amount of slack in the line so that when the waves hit the boat, it doesn't pull up on the line and uproot the anchor.

Next, connect the anchor rode to the boat. On a pontoon, you can attach the line to a cleat or use a Danik hook to clip it onto a loop on the front of the pontoon. Remember that an anchored boat will still move, so be cautious of those around you.

When pulling the anchor back in, remember not to place it on the furniture or floor. Have a designated spot inside a seat or use the in-floor storage space to avoid staining anything with mulch and debris. Some Barletta models even have a designated anchor storage area at the bow.



⚠ WARNING *Sinking Hazard: In waters with strong currents, always anchor from the bow and do not add an anchor at the stern. A small amount of current will make a boat unsteady. A strong current can pull a boat anchored by the stern under the water and keep it there.*

⚠ WARNING *Collision Hazard: ALWAYS anchor in areas where the boat will not disrupt other boats. Do not anchor in a channel or tie up to any navigation aid. It is dangerous and illegal.*

Helpful guidelines when anchoring:

- Make sure the anchor line is tied to the anchor. Tie the other end of the line to the forward cleat or bow eye.
- Head the boat into the wind or current over the spot where you want to lower the anchor.
- Stop the boat before lowering the anchor.
- Scan the shoreline for signs of underwater cables or pipes and avoid these areas.
- Slowly lower the anchor until it hits bottom.
- Allow the boat to back away, keeping tension on the line.
- Release at least six to seven times as much line as the depth of the water.
- Secure the anchor line to a designated strong point, typically the bow eye or dedicated anchor bit.
- Firmly pull on the line to make sure the anchor is holding.
- Occasionally check your position against the shoreline. If the anchor is dragging and the boat is drifting, reset the anchor.



Helpful guidelines when weighing (pulling in) the anchor:

- Start the engine(s).
- If necessary, move forward until enough tension is off the anchor line to allow for retrieval of the anchor. Avoid running over the anchor line; retrieve the line as you approach the anchor.
- Once the anchor line is straight up and down, lift the anchor from the bottom.
- If the anchor is stuck, attach the anchor line to the bow cleat so it is tight. The up-and-down motion of the bow from wave action may loosen the anchor from the bottom. If the anchor remains stuck, let out a few more feet of line and attach it to the bow cleat. While keeping tension on the line, slowly maneuver your boat around the anchor to help loosen it. Avoid running over the anchor line.
- Always stow and secure the anchor and line before departing.

LINES AND KNOTS

Mooring, anchor and other nautical lines are constructed from many different types of materials, and are available in many diameters and styles. Consult with your local marine supply store for a recommendation of appropriate lines for the boat and application. Commonly used mooring lines are constructed of a high-quality synthetic material in a double-braided configuration and usually have eye splices on at least one end.

Learn and become familiar with tying and using knots. Knowing how to use knots and lines properly can prevent personal injury and property damage.

Practice tying lines to docks, cleats and anchors, and connecting two lines together. Consult other qualified boaters or the boat dealer, or visit the local bookstore, library or the Internet for information on the proper use of nautical lines and knots. The following illustrations represent a few examples of securing mooring lines.

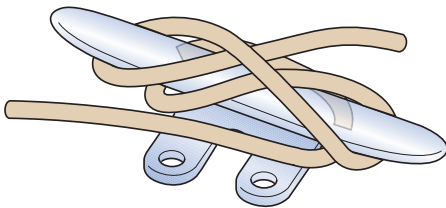

Cleating an open line

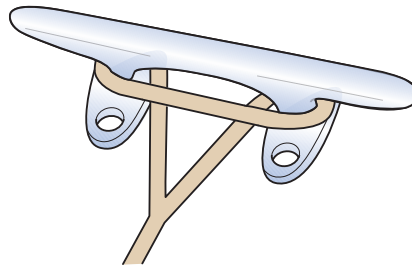

Cleating an eye-spliced line

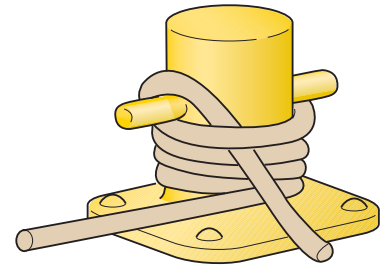

Securing to a dock bitt

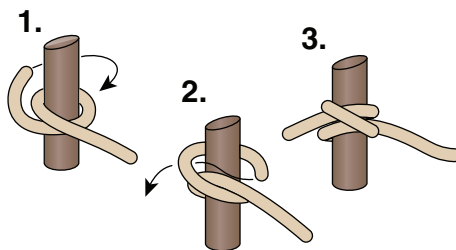

Securing load line (clove hitch)

A “double half hitch” should always accompany a “clove hitch” on the load line.

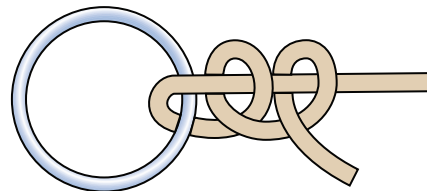

Securing load line (double half hitch)

KCB-0088

Section 10

TRAILERING AND LAUNCHING

Before using the trailer, review *Safety in Section 2*.

LEGAL CONSIDERATIONS

The following information is intended as a basic guideline only. See the *Trailer Operator's Manual* for information on operation, adjustments and maintenance.

Before using the trailer, contact your state's Department of Motor Vehicles (and that of other states through which you may be traveling) for information on trailering regulations. Trailer regulations vary widely from state to state, and it is your responsibility to be in compliance with all regulations when trailering the boat.

Regulations include, but are not limited to, trailer registration, licensing, width, height, length, lights, safety chains, tie-downs, hitch type, weight capacity, brakes, spare wheels, vehicle mirrors and gross vehicle weight.

TRAILER CLASSIFICATION

Trailers are separated into four classes based on the Gross Vehicle Weight Rating (GVWR):

TRAILER CLASS	GVWR
Class One	under 2000 lb (907 kg)
Class Two	over 2000 lb (907 kg) and under 3500 lb (1588 kg)
Class Three	over 3500 lb (1588 kg) and under 5000 lb (2268 kg)
Class Four	over 5000 lb (2268 kg)

TRAILER TYPE

There are two types of trailers recommended for pontoon boat applications. To prevent damage to the boat and/or personal injury, always use the appropriate trailer for proper support of the boat. To avoid corrosion in saltwater applications, do not use carpeted bunks on lifts and/or trailers. Carpeted bunks become saturated with salt water and will corrode raw aluminum pontoon tubes. Contact your dealer for more information.

SCISSOR-STYLE TRAILER

Scissor-style trailers are constructed with a center lift mechanism that sits between the tubes of the boat. The lift is attached to a winch that lowers and raises the entire boat. This style of trailer is not recommended for long distance tows, but is better suited for shallow waters because of its lifting and lowering mechanism.



BUNK-STYLE TRAILER

A bunk-style trailer has bunks that cradle each toon in place. The toons nestle down into the bunks and are less susceptible to teetering and movement while towing down the road. This style can be built for pontoons with two or three tubes. This type of trailer does not have a lowering mechanism so this style can be more difficult during launch in shallow waters.



TRAILER GROSS VEHICLE WEIGHT RATING

All trailers must display a Gross Vehicle Weight Rating (GVWR) decal, which shows the load-carrying capacity plus the weight of the trailer. The total weight of the boat (fully loaded with fuel, batteries, water, etc.), engine, gear and trailer must never exceed the GVWR.

TOWING VEHICLE

The towing vehicle must be able to safely pull the full trailer and boat load. Never pull a trailer load that exceeds the vehicle's towing capacity; you risk losing control of the trailer and/or vehicle. Before trailering, always check the *Vehicle Operator's Manual* for maximum towing/trailering load specifications and maximum gross vehicle weight specifications that include the fully loaded trailer.



SECTION 10

TRAILERING AND LAUNCHING

VEHICLE TOWING HITCH

The towing vehicle must be able to safely pull the full trailer and boat load. The vehicle must have a towing hitch that is capable of safely handling the trailering load and tongue weight of the trailer.

Hitches are designed for many applications and can vary in style. Use professional assistance when selecting the correct hitch and hitch ball for the towing application.

⚠️ WARNING *Control Hazard: A vehicle hitch that is underrated or improperly installed can lead to loss of control of the trailer and/or vehicle. Never use a hitch that is not rated to pull the maximum weight of the trailering load or that is not rated for the maximum tongue weight that the trailering load applies.*

Hitches are divided into classes that specify the trailer's gross trailer weight and maximum tongue weight for each class.

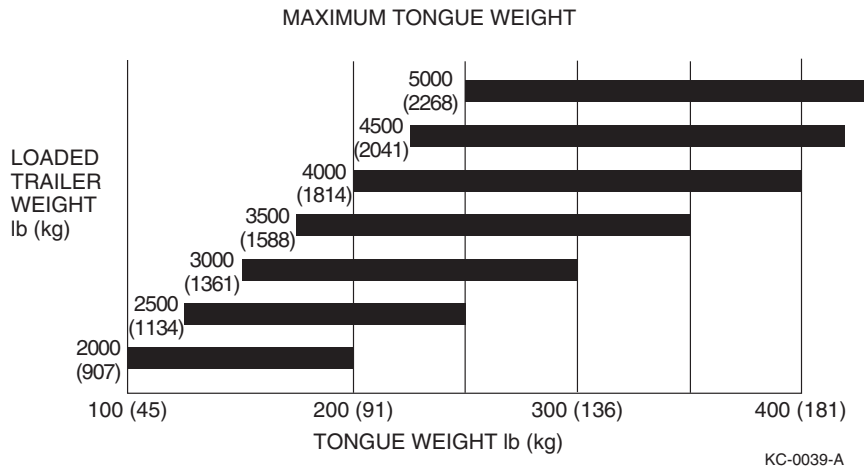

HITCH BALL AND TRAILER COUPLER

Most boat trailers have a coupler that connects to a hitch ball attached to the towing vehicle's hitch. The trailer hitch coupler must always match the size of the hitch ball. The correct hitch ball diameter for the coupler is usually marked on the trailer coupler.

⚠️ WARNING *Control Hazard: Never use a hitch ball size or rating that does not match the trailer coupler specifications. Using an improper size or rated hitch ball can lead to loss of control of the trailer and/or vehicle.*

Trailer hitch balls are sized and rated for use based on the trailer GVWR:

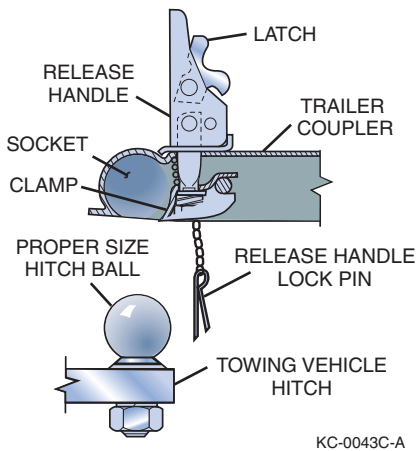

TRAILER CLASS	GVWR	HITCH BALL DIAMETER SIZE
Class One	under 2000 lb (907 kg)	1-7/8 in. diameter size
Class Two	over 2000 lb (907 kg) and under 3500 lb (1588 kg)	2 in. diameter size
Class Three	over 3500 lb (1588 kg) and under 5000 lb (2268 kg)	2 in. diameter size
Class Four	over 5000 lb (2268 kg)	2-5/16 in. diameter size



SAFETY CHAINS

The boat trailer's safety chains prevent the trailer from completely detaching from the towing

vehicle when underway. Connect the chains to the vehicle's hitch or frame and crisscross the chains under the trailer tongue to prevent the tongue from dropping to the road if the trailer separates from the hitch ball. Rig the chains as tight as possible with enough slack to permit full-free turning. Safety chains must be rated at the same or greater weight capacity as the trailer's GVWR.

Never allow the chains to drag on the ground when trailering.

Attach the chains properly and securely between the towing vehicle and trailer before trailering.

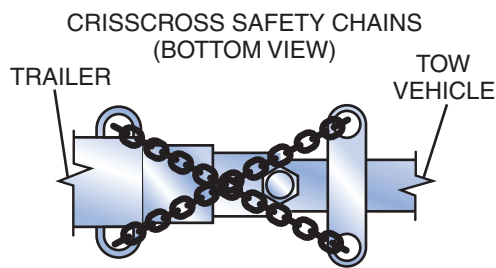

KC-0045C-A

TRAILER BRAKES

In some states, any trailer with a GVWR of 1500 lb (680 kg) or more is required to have trailer brakes. Check with your state and local authorities for more information.

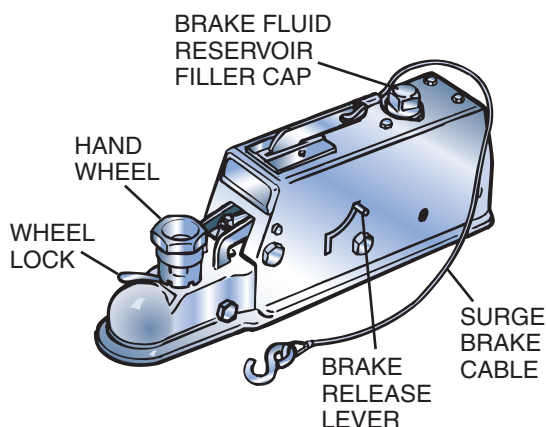

KC-0044C-B

The three basic types of trailer brakes are electric, hydraulic surge and air-actuated. If the trailer is equipped with brakes, see the *Trailer Operator's Manual* for more information on operation, adjustments and maintenance.

5-PIN WIRING CONNECTOR

Some trailers equipped with surge brakes may utilize a 5-pin wiring connector. These trailers use an electric solenoid valve that allows brake fluid to bypass back to the reservoir while in REVERSE. The solenoid is usually connected to the reverse lights on the tow vehicle to ensure the brakes only bypass in REVERSE. The fifth pin is for deactivating the brakes when backing up, and is required to be connected to the vehicle's power when backing up.

TRAILERING GUIDELINES

ENGINE-TRANSOM SUPPORT BRACKET

The trailer must be equipped with an engine-transom support bracket for each engine. The support must transfer the weight of the engine to the trailer cross-member. Devices that are used between the engine and engine transom bracket do not provide adequate protection. Damage to the transom motor pod, engine and trailer from shock loads is not covered by the boat, engine or trailer warranties.

Follow these guidelines when trailering:

- Before driving, make sure the vehicle maintenance and trailer maintenance are current. This is very important because towing puts additional stress on the tow vehicle.
- Make sure the wheel lug nuts/bolts on the tow vehicle and trailer are tightened to the correct torque.
- Be sure the hitch, coupler, draw bar and other equipment that connect the trailer and the tow vehicle are properly secured and adjusted.
- Make sure all running lights, brake lights, turn signals and hazard lights are working.
- Verify that the brakes on the tow vehicle and trailer are operating correctly.

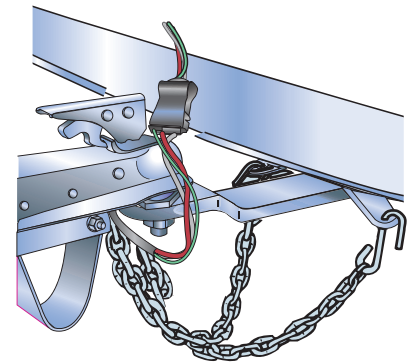

KC-0046C-A



- Maintain a safe speed as regulated by the trailering laws of the state where you are traveling.
- Check the trailer and vehicle brakes for proper operation and fluid level prior to departure.
- Check the trailer for damage prior to departure.
- Make sure the hitch ball and trailer coupler are the same size and bolts and nuts are tightly secured.
- The coupler must be completely over the ball, and the latching mechanism must be locked down.
- Make sure the safety chains are properly crisscrossed and connected. They should not touch the road but should have enough slack to make turns. If the ball were to break, the trailer would follow in a straight line and prevent the coupler from dragging on the road. Make sure the trailer emergency brake cable or chain is also installed to the tow vehicle frame.
- Ensure the breakaway system lanyard is connected to the tow vehicle and not to the safety chains or ball mount.

NOTE — Make sure the towing vehicle and trailer are in compliance with all state and local laws. Contact your state motor vehicle bureau for laws governing the towing of trailers.

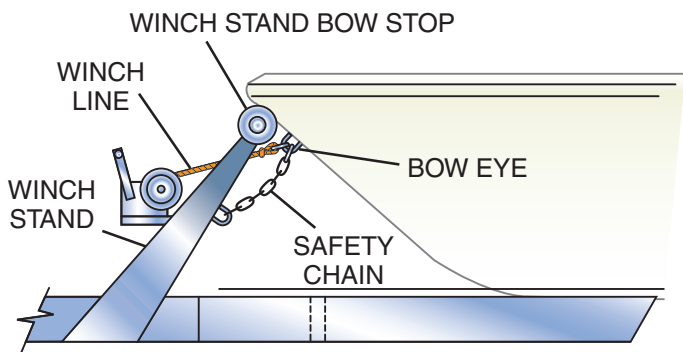

- Check trailer wheel bearings before each trip.
 - Secure the stern of the boat to the trailer from the stern eyes.
 - Fasten the bow of the boat to the trailer with the bow winch line connected to the bow eye and bow safety chains.
 - If travel conditions require, use an additional tie-down strap across the rear of your boat from side to side to further secure the stern.
 - Check all strapping material for wear.
 - Check that the wiring is properly connected. It should not touch the road but should be loose enough to make turns without disconnecting or damaging the wires.
 - Too much or too little tongue weight makes steering difficult and causes the tow vehicle to sway. Put approximately 5% to 10% of boat and trailer weight on the tongue.
 - Drive with the vehicle and trailer running lights on.
 - Check load distribution to make sure the tow vehicle and trailer are properly balanced front to back and side to side.
 - Check that all items are securely fastened on and in the trailer.
 - Be sure the trailer jack, tongue support and any attached stabilizers are raised and locked in place.
 - Check side-view mirrors and rearview mirrors for good visibility.
 - Check routes and restrictions on bridges and tunnels.
 - Keep wheel chocks and jack stands on hand.
 - Side curtains, backdrop, aft curtains, convertible tops and detachable windshields are not designed to stay on boats at highway speeds. Before towing, take down the convertible top, side curtains, back cover and detachable windshield, if equipped.
 - Remove any covers that are not designed to stay on boats at highway speeds.
- Once the trailer is secured to the vehicle hitch, stow the trailer jack or lift so that it will not hit the ground.
 - Check and correct tire pressure on the tow vehicle and trailer, including the spare tire. Under-inflated tires heat up rapidly and may cause tire damage or failure. The proper tire pressure is listed on the trailer certification plate.

- Carry a spare tire and wheel for both the trailer and the towing vehicle, along with tools to change them.
- See the *Engine Operator's Manual* for engine-related trawling information. Continuous road shocks may fatigue the boat's steering system.
- Tie outboard motors in place so they will not tilt or turn from road shock.
- On extended trips, carry spare wheel bearings, seals and races.
- While traveling, check the wheel hubs every time you stop. If the hub feels abnormally hot, inspect the bearing before continuing your trip.
- Carry a fire extinguisher in the vehicle.
- Turn carefully while towing a trailer; additional space and distance are needed.
- Drive slowly over railroad tracks or rough roads.
- While trawling the boat from lake to lake, boaters may unknowingly introduce a foreign aquatic species from one lake to the next. Thoroughly clean the boat below the waterline, remove all weeds and algae and drain the bilge and livewells before launching it in a new body of water.

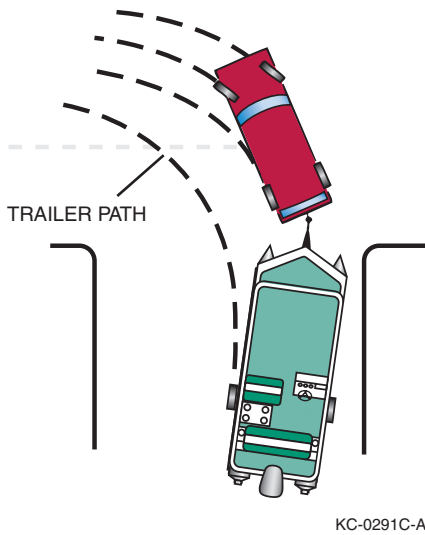

PONTOON BOAT CONSIDERATIONS

Because of the boat and trailer designs, pontoon boats require additional considerations when towed on the roadway.

- Be sure the trailer meets your needs. Scissors-type trailers are best for limited travel or shallow water load/unload, drive-on trailers are best for driving extended distances. If you have a tri-pontoon boat, the center pontoon must be supported by the trailer if tied to the engine mount.
- If your pontoon boat has twin engines, do not use a scissors-type trailer.
- Scissors-type pontoon boat trailers have narrow axles (tires inside the pontoons) and are inherently less stable. Use extra precaution with turns and lane changes, and use additional tie-downs to prevent boat movement.
- If you have a drive-on style trailer and use your pontoon boat in salt, brackish or polluted waters, you must apply a suitable bottom paint to all areas of the pontoon submerged in water. Also, flush the trailer bunks with fresh water as soon as possible after loading the boat to minimize corrosion damage.
- If a pontoon has been damaged and contains water, drain the water before trawling. Remove the boat from the water and allow it to drain completely before traveling on the road. If the pontoon is not equipped with a drain plug, consider drilling a small hole (no larger than 7/16" for easy repair) in the bottom of the pontoon and allow water to drain; consult your dealer or certified aluminum welder for repair.
- Keep trawling speeds under 45 mph (72 kph) and be mindful of traffic behind you. Common courtesy calls for you to safely pull over and let any traffic that might stack up behind you to pass from time to time.
- If you are passing, keep in mind the added length of the tow vehicle and boat, and allow enough room to smoothly merge back into the lane. Sudden lane changes could cause the trailer to weave and become unstable.
- If a truck or large vehicle passes you, be aware that the wind turbulence may push the trailer. The trailer will stabilize itself after the vehicle passes. Do not brake to adjust.
- Always close and lower the convertible top using the trawling struts if equipped and secure them.



⚠ WARNING *Highway Towing Hazard: Pontoon boats require special attention when towing on roads:*

- **Do not tow faster than 45 mph (72 kph). The combination of being light in the bow and the outboard leveraged on the motor pod may not give sufficient tongue weight to prevent trailer sway.**
- **Allow increased distance between vehicles of at least two lengths per every 10 mph (16 kph) to improve reaction time and safe stopping distance in case of emergency.**
- **Know the overall height of the boat on the trailer and add 8 in. (203 mm) as a safety factor. Avoid overhead obstacles on the route that may not allow enough clearance such as filling stations, drive-thrus and rural bridges.**
- **Improper towing could result in death or serious injury.**

BACKING UP

If you have never towed a trailer before, take time to practice and become comfortable with backing up the boat and trailer. Situations can arise in traffic, or when launching, that will require you to be able to back up the trailer safely.

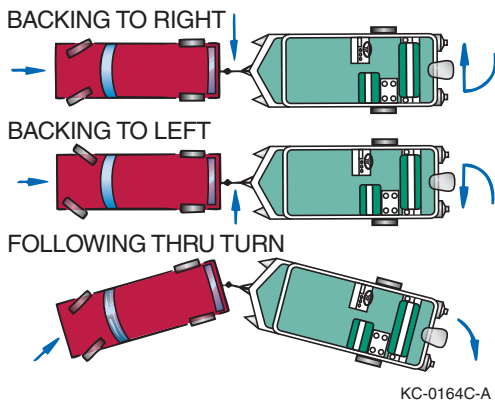

KC-0164C-A

Follow these guidelines when backing a trailer:

- Back slowly and make small steering adjustments.
- Turn the car wheels in the direction opposite where you want the trailer to go.
- After the trailer begins moving, turn the car to follow it.
- Have a second person assist you with audible and hand signals.

LAUNCHING

Before launching, inspect the launch ramp for any problems that may hinder launching or make launching unsafe. Ramps can be slick and dangerous to drive or walk on, and may have unseen drop-offs beneath the water that would pose a safety hazard. Always be aware of water conditions and the effects of the wind when launching.

Before launching, inspect the boat and trailer for damage. Do not launch if you detect damage or find that the engine or propeller is not in good operating condition. Have any repairs made before launching.

Use courtesy when preparing the boat for launching by preparing away from the ramp on level ground before proceeding to the launch ramp.

When launching the boat on the trailer, have two or more people assist you. Since all launches are different, the following procedures are intended as guidelines only:

- Verify that the vehicle's brakes, including the parking brake, are in proper working order.
- Make sure the trailer is securely fastened to the vehicle.
- Remove the boat cover, if equipped.
- Check that the bilge drain plug is in place and all other plugs that allow water to leak into the boat are in place.
- Remove all tie-downs from the boat.
- Attach the bow and stern docking lines.
- Attach boat fenders if necessary.
- Disconnect the trailer's light harness from the car.
- If applicable, trim or tilt the engine/outdrive up to avoid damage.
- Make sure the bow winch and strap are securely locked and fastened.
- Make sure the bow winch safety chains, if equipped, are in place.
- Make sure all required documentation and safety equipment are on board.
- Verify that batteries are fully charged and in good condition.
- Check fuel level; add fuel if necessary.
- Always launch with the help of another person.
- Make sure there is no one on the ramp behind the boat.
- Keep the trailer/vehicle combination as straight as possible and at 90 degrees to the shoreline.

- Back slowly down the ramp until the transom of the boat is a few inches in the water; then stop the vehicle.
- Stop the vehicle and shift into PARK (automatic transmission) or REVERSE (manual transmission). Apply the brakes and/or parking brake. If possible, use wheel blocks.
- Position the mooring lines within reach of the dock.
- Disconnect the bow winch strap and safety chains, if equipped, from the bow eye.
- Manually back the boat clear of and off the trailer into the water and secure to the dock using mooring lines.
- Remove any wheel blocks and release the vehicle brakes. Pull the trailer slowly out of the water, and secure and park in a designated area.
- Board the boat.
- Lower the engine/outdrive, if applicable.
- Run the bilge blowers as required, if equipped.
- See the *Engine Operator's Manual* for starting procedures.
- Remove dock lines from the dock and proceed slowly away from the dock.
- Back the trailer slowly down the ramp until it is positioned so that the boat can be loaded.
- Stop the vehicle and shift into PARK (automatic transmission) or REVERSE (manual transmission). Apply the brakes and/or parking brake. If possible, use wheel blocks.
- Position the mooring lines within reach of the dock.
- Manually position the boat onto the trailer using mooring lines. Make sure it is centered on the supports of the trailer.
- Position the bow eye into the bow stop and connect and secure the bow winch strap and safety chains, if equipped, to the bow eye.
- Secure the mooring lines inside the boat.
- Remove any wheel blocks and release the vehicle brakes. Slowly pull the trailer and boat up the ramp.
- Secure the transom to the trailer.
- Prepare for trailering as necessary.

REPORTING SAFETY DEFECTS

If you believe that your boat trailer has a defect which could cause a crash or could cause injury or death, you should immediately inform the National Highway Traffic Safety Administration (NHTSA) in addition to notifying the trailer manufacturer.

If NHTSA receives similar complaints, it may open an investigation, and if it finds that a safety defect exists in a group of trailers, it may order a recall and remedy campaign. However, NHTSA cannot become involved in individual problems between you, your dealer or the boat manufacturer.

To contact NHTSA, you may call the Vehicle Safety Hotline toll-free at 1-888-327-4236 (TTY: 1-800-424-9153); go to <https://www.nhtsa.gov>; or write to Administrator, NHTSA, 1200 New Jersey Avenue SE, Washington, DC 20590. You can also obtain other information about motor vehicle safety from <https://www.nhtsa.gov>

LOADING GUIDELINES

Follow these guidelines while loading the boat onto the trailer:

- When loading the boat on the trailer, have two or more people assist you.
- Stop, turn off the engine and secure it to the dock with dock lines at a position clear from where the trailer will be in the water.
- If applicable, trim or tilt the engine/outdrive up to avoid damage.
- Verify that the vehicle's brakes, including the parking brake, are in proper working order.
- Disconnect the trailer's light harness from the tow vehicle.
- Make sure the trailer is securely fastened to the vehicle.



SECTION
10

TRAILERING AND LAUNCHING

This Page Intentionally Left Blank

Section 11

GENERAL CARE AND MAINTENANCE

The boat may feature a variety of specialized systems and components. The following basic and typical information may not apply to your specific application. This section may not cover all systems or components on the boat. See the *Engine Operator's Manual* or the equipment manufacturer's information for maintenance procedures.

Maintenance procedures may require special knowledge and equipment. Always consult the boat dealer for assistance in performing service, maintenance or modifications to the boat.

Neglect of maintenance and unauthorized service work is not recommended and may void your warranty. Refer to the *Engine and Equipment Manufacturer's* maintenance schedules and requirements, and keep a detailed log of the procedures and dates completed. Always consult the boat dealer for assistance with periodic maintenance.

Before performing any general care and maintenance procedures within this section, review *Safety in Section 2*.

SAFETY EQUIPMENT

Periodically check the safety equipment for damage, general condition and operation when applicable. Always replace safety equipment that is in question or in need of repair:

- Fire extinguisher
- Life jackets
- Visual distress signaling devices
- Audible signaling devices
- Navigational lights
- Emergency radios or Emergency Position Indicating Radio Beacon (EPIRB) or Personal Locator Beacon (PLB)
- First aid kit
- Batteries in electronic devices
- Ditch kit
- Life raft

LIFE JACKETS

Maintaining life jackets is important to extending their life. Proper cleaning/sanitation will help rid life jackets of sunscreen, mold and mildew that may break down materials over time. When cleaning, be sure to inspect life jackets for wear and tear that might require repair or replacement. Life jackets are often neglected until they are needed. Consult the life jacket's owner's manual or website for more information.

Use and Storage

Life jackets that are wet, dirty, or stored in humid conditions can deteriorate quickly. Sunscreen products and body oils can accelerate deterioration. The following tips will help to extend the life of life jackets:

- After use, air-dry jackets out of direct sunlight and away from tree sap. If on the boat, choose a well-ventilated space.
- If you can't air-dry outside, place the jackets on hangers, space at least 6 inches apart, and ventilate with an oscillating fan.
- If dirty (sand or stains) or used in salt water, rinse jackets with plenty of fresh water.
- If stained from sunscreen, foods, or other sources, clean as soon as possible.
- Clean life jackets at least annually.

Do Not:

- Use chlorine bleach directly on a jacket, as it can break down fabrics and interior foam.
- Clean jackets with industrial cleaning agents or something like gasoline, paint thinner or acetone. They can dissolve the foam that makes the device functional and weaken the exterior fabric.
- Machine-wash, dry-clean or use strong detergents or degreasers.
- Dry jackets with a direct heat source or clothes dryer.
- Bend life jackets or place heavy objects on top of them, as this can cause crushing and damage performance.



Cleaning Life Jackets:

Clean the life jackets annually at the end of the season. To clean:

- Fill a bucket with cool water and about two tablespoons of mild liquid laundry detergent.
- Lay a tarp on the ground and place the life jackets, with all straps and hardware unfastened, on the tarp.
- Treat stains with a laundry pre-wash stain remover, work it in with a soft brush and allow it to work for 5 minutes.
- Scrub all surfaces of the jacket using the detergent solution and a soft brush.
- If the jacket has mold or mildew, move it to an outside area and brush away any visible spores before wetting the fabric. Scrub as suggested but add 1/4 cup of oxygen-based bleach to the cleaning solution to help remove dark stains.
- Rinse well using plenty of clean water.
- Hang the jacket to drip-dry out of direct sunlight.
- Place the jackets on hangers, space at least 6 inches apart, and ventilate with an oscillating fan until completely dry.
- Store life jackets in a dry, cool, dark place.

BOATING EQUIPMENT

Periodically check the general equipment on board for damage, general condition and operation when applicable. Always replace equipment that is in question or in need of repair.

- Anchors and anchor lines
- Boat hook
- Dock fenders
- Foul weather gear/clothing
- Mooring lines
- Oars/paddles
- Tool kit
- Tow line

CORROSION PROTECTION

GALVANIC CORROSION

Galvanic corrosion (electrolysis) is the deterioration of metals from the effects of electrolytic action. When two dissimilar metals are immersed in a conductive fluid such as salt water, an electric current is produced, much like a battery. As current flows between the two metals, the softer, or sacrificial, metal deteriorates.

If you operate in salt, polluted or brackish waters, the boat should be equipped with a transom-mounted sacrificial anode to prevent corrosion damage to other metal parts of your boat that are in contact with the water. The anodes are self-sacrificing and are slowly eroded by electrolytic action. These anodes are important and require periodic inspection for deterioration. Replace the anode when it is less than 50% of its original size.

Most propulsion units and transom-mounted accessories are equipped with one or more anodes that require periodic inspection. See the propulsion/ accessory *Operator's Manual* for maintenance procedures.

NOTICE

Do not paint or coat sacrificial anodes or cathodes with any substance. Once covered, they do not provide protection from galvanic corrosion. Replace anodes if they have deteriorated 50% or more.

Optional, electronic cathode systems are designed to reduce the effects of electrolysis by emitting an electrical low-current charge into the water near the metal components' neutralizing electrolytic action.

SALTWATER CORROSION

Any boat exposed to salt water can be affected by the salt. However, to minimize the effects of salt water on boats, consider the following preparation and maintenance. Corrosion prevention is key and proper maintenance will mitigate the damaging effects of salt water.

If you plan to use your boat in salt water, all portions of the boat that will be submerged should be painted with an approved anti-fouling paint. This service is provided by your dealer or by someone recommended by your dealer. There is an extra charge for this service.



If you trailer your boat and use it in salt water, be sure that the bottom of the boat has a barrier between it and the bunks. If anti-fouling paint is not used, salt water trapped in the trailer bunks can cause corrosion at the point where the trailer bunk meets the hull.

In some cases you may need to have sacrificial anodes added to your boat to prevent electrolysis. Ask your dealer whether he recommends adding anodes. There is an extra charge for this service.

Some boats and/or propulsion systems may be designated as “Saltwater Series.” This designates that additional design and/or materials are used to make them more resistant to the effects of salt water, but not “saltwater proof.” The following maintenance also applies to saltwater series products.

Maintenance

Removing saltwater deposits from the boat as quickly as possible is the key to keeping saltwater corrosion in check.

- Rinse the boat hull and deck with fresh water and wash immediately after using the boat in salt water. Allow the boat to dry before covering it with the mooring or seat covers.
- Flushing the engine cooling system is recommended when the engine has been used in salt, polluted or brackish waters. Flush the entire engine cooling system with fresh water for at least 5 minutes after use in these waters. See the *Engine Operator's Manual* for the flushing procedure. Consult the boat dealer for suitable flushing equipment.
- You should repair paint chips and scratches when you start to notice bare metal showing. Do not paint any sacrificial anodes; rather, remove any oxidation with sandpaper.
- Cover your boat WHEN DRY with seat covers or a mooring cover to keep salt and weather off of your boat. Since most saltwater areas are very humid it is imperative that the boat be dry before it is covered. If you cover it wet you will see mildew develop.
- A yearly inspection for corrosion or deterioration of the electrical connections is recommended.
- If the boat is used primarily in salt water, wax the hull monthly and apply corrosion inhibitor to all hardware.

ALUMINUM PONTOONS AND HULLS

In addition to the general saltwater corrosion maintenance, aluminum pontoons/ hulls require more considerations when used in salt, brackish or polluted waters. Even the highest-quality marine aluminum can quickly suffer damage from salt water. To protect your investment:

- Never moor an aluminum boat in the water for more than a few days. Flush with fresh water as soon as possible.
- Remove your boat from the water when not in use. Flush with fresh water as soon as possible.
- It is imperative to apply anti-fouling paint as a barrier. This paint does not prevent corrosion; it only mitigates corrosion and marine growth.
- If you trailer your boat you MUST flush the salt water from the bunks before loading. Salt water between the bunks and the pontoons/hull will cause rapid corrosion.
- If you use a boat lift, flush the bunks before and after loading. Remove the boat from the water every two weeks to clean and inspect for corrosion damage.
- If corrosion is evident, talk to other boaters in the area about bottom paints and sacrificial anodes that work for them.
- Consider adding additional sacrificial anodes along the hull. Talk to your dealer.

Check pontoons routinely for dents, leaks or minor damage from regular use. Bumping a rock, log or dock can cause damage that may not be apparent at first; however, these leaks can cause the pontoons to take on water slowly but surely. This water is a safety concern and will weigh down the boat, decrease performance, put unnecessary strain on the engine, and increase fuel consumption.

If you notice your boat sitting lower in the water, or one pontoon sitting significantly lower than the other, water has likely collected in one or more pontoon. You may notice one pontoon sitting slightly lower than the other when your gas tank is filled; this is normal.

Many pontoon boats have drain plugs in the bottom of each pontoon. Since the plugs usually sit below water level, the boat must be removed from the water to drain. If water drains, you must identify and repair the source of the leak. If you have a leak, do not use the boat and contact your dealer immediately.



SECTION 11

GENERAL CARE AND MAINTENANCE

SACRIFICIAL ANODES

Anodes (sometimes called “zincs”) are used to protect hardware exposed to the water. Since galvanic corrosion attacks the least “noble” metals first, less noble metal anodes are used to purposefully “sacrifice” themselves, thereby protecting the more noble metals of the drives, propeller, tabs, boarding platform and other metal items below the waterline (such as underwater gear).

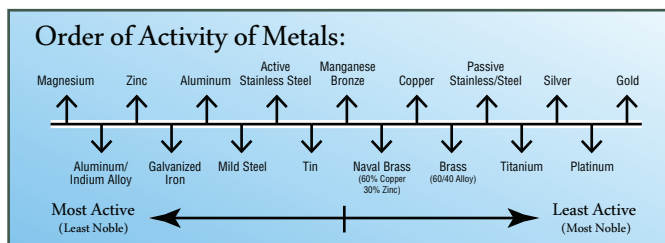

KC-6009

Anodes may be installed on the boat transom and/or bottom at the factory. Additional anodes may be installed on the underwater gear as well as any metal components exposed to seawater, such as engine and air conditioning heat exchangers and water cooling jackets. Anodes are made in three different metals which must be matched to the water type and local conditions. Most boats are equipped from the factory with zinc anodes on the recommendation from engine and drive manufacturers. The anodes that are installed on the trim tabs are typically zinc and are isolated from the boat bonding system.

Selection, monitoring and replacement of the anodes on the transom, drives, trim tabs, boarding platform supports and other underwater gear is very important and the customer’s maintenance responsibility. Any damage done because of lack of maintenance will not be covered under warranty.

WATER TYPE	ANODE MATERIAL	REPLACE AT
Salt water	Zinc	40% decomposition
Brackish water	Aluminum	50% decomposition
Fresh water (clean)	Aluminum/magnesium alloy	50% decomposition
Fresh water (polluted)	Magnesium	40% decomposition

NOTICE

To be effective, anodes must be bare metal. If the boat is dry-docked more than 24 hours, sand the anodes to clean oxidation from the surface.

- Zinc and aluminum anodes left in fresh water or zinc anodes used in brackish water will become covered with white oxide which effectively stops the sacrificial process and exposes the underwater gear to damage.
- Do not paint sacrificial anodes. Bottom paints/sealants on anodes will block the sacrificial process and expose the underwater gear to damage.
- Depending on local conditions, some anodes can deteriorate very quickly and must be closely monitored. See the boat dealer for recommendations.

Because of the vital function that anodes play in the protection of underwater gear, replace anodes at the recommended level of decomposition, or annually, with the correct type. Boats stored in salt water will normally need to have the anodes replaced every 6 months to one year.

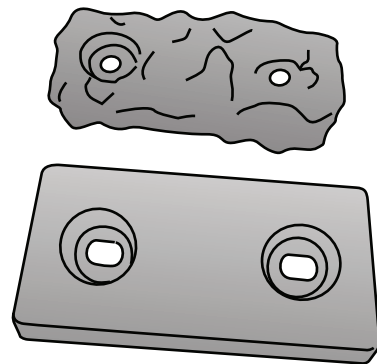

KC-6006

Anodes requiring replacement more frequently may indicate a stray current problem within the boat or at the slip or marina.

Anodes that do not need to be replaced after one year may not be providing the proper protection. Loose or low-quality anodes could be the problem. There could also be a problem in the bonding system or the wrong anode material is being used.

The boater/customer has the responsibility in maintaining and ensuring that the proper anodes are installed for the area (water) in which the boat will be used. See the boat dealer about changing material or adding additional anodes.



HARDWARE, FASTENERS AND FITTINGS

Check all fasteners, fittings, hinges, latches, rails and cleats for corrosion and tightness. Repair or replace any items that need attention. Never use automotive replacement parts when replacing marine parts.

Periodically clean all hardware with approved marine cleaners or mild soap and water. Never use abrasive cleaners or materials; they will scratch the polish and protective coatings on the hardware and cause the hardware to corrode. Applying a coating of marine-grade wax can help maintain the original shine of the hardware and help prevent corrosion.

ELECTRICAL SYSTEM

Before performing any work on the electrical system or the battery, review *Safety in Section 2*.

BATTERIES

⚠ WARNING *Electrical Shock Hazard: Always disconnect the batteries before performing maintenance on the DC electrical system. Electrical shock may occur if the batteries are not disconnected during maintenance on the DC electrical system.*

⚠ WARNING *Personal Injury Hazard: Always wear gloves and protective eyewear when working on and around the batteries. The batteries contain an acid called electrolyte. Avoid causing damage that could spill electrolyte into the bilge when servicing the batteries. Avoid getting salt water in or on the battery. Either condition can create a poisonous gas that is harmful if inhaled. Always disconnect the batteries before cleaning.*

⚠ CAUTION *Personal Injury Hazard: Never allow a tool to bridge across the battery terminals. Injury can result if the terminals are accidentally bridged with a tool or other conductor.*

Today's boats can be loaded with electronics that all run off the boat's battery. Because of this, many boats will have two or more batteries: one for starting and running the engine, and one for electronics, commonly referred to as the house battery. One advantage is that the starting battery will not be drawn down when using

electronics with the engine off, such as with a stereo. Another advantage is if the starting battery has lost capacity because of age, the battery switch has a 1+2 (Both) position that parallels both batteries for emergency starting. See the *Battery Switch* section of this manual for more information.

Marine batteries generally come in two types: starting and deep-cycle. Starting batteries are similar to car batteries, can supply lots of current for a short period of time and are used for starting the engine. Starting batteries should be recharged almost immediately and do not tolerate deep discharges. Deep-cycle batteries are designed for repeated discharging and recharging cycles without damage. They are used as the house battery on boats with higher DC power requirements.

All batteries have one thing in common — they run for a while, need recharging and require an eventual replacement as the capacity fades. Most marine batteries are sealed and require no maintenance other than keeping them at a full state of charge and diligently cleaning corrosion from the terminals. To maintain long life, deep-cycle batteries should not be discharged more than 50% before they are recharged.

Most marine batteries are flooded, sealed lead-acid, but there are several different battery types/chemistries that could be used. You must use caution when charging or replacing the batteries; replace batteries with the exact same type, group and capacity. If your boat is not equipped with an onboard battery charger, use a smart charger suitable to your battery type/chemistry.

⚠ CAUTION *Burst Hazard: Never use an automotive type (lead-acid) battery charger to charge a gel cell type battery. Doing so will cause damage to both the charger and battery and can cause the battery to burst. Use a battery charger specifically designed to charge gel cell type batteries.*

Always turn off the battery switch (if equipped) or disconnect the negative battery cable before servicing the electrical system.

NOTICE *The following information applies to lead-acid batteries. If you replace the batteries with batteries using different chemistry such as Li-Ion, you must follow the battery manufacturer's instructions for inspection, maintenance and charging.*



Refer to the OEM information for operation details.

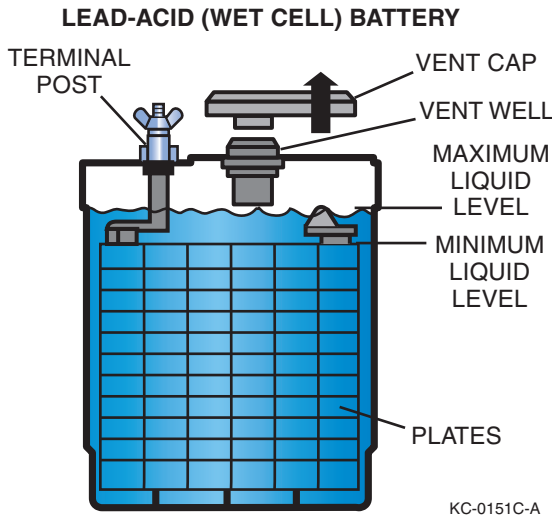

When you install a battery:

- Make sure the battery terminals are clean.
- Be certain to use correct polarity when you connect the battery cables to the battery.
- Make sure the cable connections are tight.
- Always shut down the engine before removing or attaching battery cables and never run the engine with the battery cables disconnected.
- Always remove the negative (-) cable first. Always attach the negative (-) cable last.

Check the battery frequently for signs of corrosion. If corrosion is evident, clean the terminal posts with a baking soda and water solution and a wire brush. Disconnect the battery terminals before cleaning.

WARNING *Burn Hazard: Lead-acid battery fluid can cause severe burns.*

Check the fluid levels in the cells.

NOTICE *Some batteries are sealed and cannot be filled. A level of approximately 1/4 to 1/2 in. (6 to 13 mm) above the plates is sufficient. If needed, fill with distilled water; do not overfill.*

During extended periods of non-use, batteries will self-discharge and should be recharged. Before recharging, disconnect the battery terminals and remove the battery from the boat. Recharge the battery according to the directions enclosed with the battery and battery

charger. When installing the battery in the boat, make sure the battery is secured in the battery box, the terminals are tight and all protective covers are in place.

WARNING *Fire/Explosion Hazard: Hydrogen gases produced by a lead-acid battery while it is charging, or the engine is running, can cause a fire and/or an explosion.*

CIRCUIT BREAKERS AND FUSES

Never exceed the recommended fuse sizes or bypass a fuse in a circuit. Always install the proper (type and rating) fuses whenever replacing or changing fuses. Continuous fuse/breaker failures indicate a severe problem and require immediate attention.

WARNING *Fire Hazard: Never reset a circuit breaker that has been automatically tripped or replace a fuse that has blown without first identifying and correcting the cause of the problem. Failure to correct the cause may result in a fire hazard.*

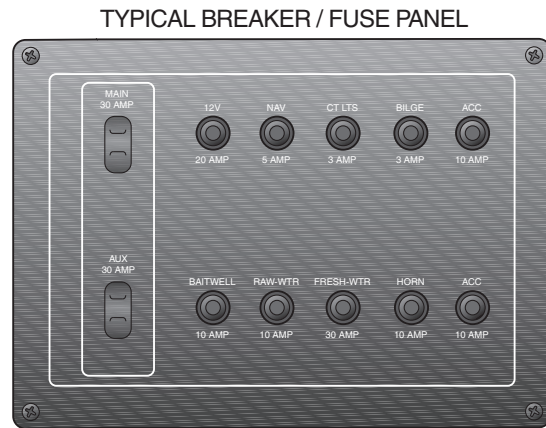

Some applications use circuit breaker switches to provide individual circuit protection with the ability to manually reset the breaker switch.

To reset a tripped circuit breaker, move the breaker switch to OFF. Identify and correct any problems with the circuit and unplug all loads connected to it. Wait a minimum of one minute for the breaker switch to cool and then push the breaker switch to ON. Turn the breaker switch to OFF immediately if it trips, and consult qualified personnel.



To replace a fuse, locate the fuse block and the failed fuse. Carefully remove the fuse without touching other fuses or wires. When possible, use a fuse removal/installation tool. Some accessories have in-line fuses accessible inside the helm or near the battery.

⚠ WARNING *Fire Hazard: DO NOT exceed the recommended fuse sizes or bypass the fuse safeguard. Always install the proper (type and rating) fuses whenever replacing or changing fuses.*

NOTICE *A boat's electrical system is designed to protect you from electrocution, short circuits and overloads. Have a qualified electrician perform any modifications to the system such as adding electrical accessories. Some installed accessories, such as stereos, have an additional fuse located in-line with the positive lead. Other accessories may use in-line fuses near the battery.*

MOTOR POD

The motor pod may accumulate trash, oil and greasy dirt over a period of time and should be cleaned periodically. Consult the boat dealer for recommendations on special environmentally friendly cleaning products and procedures.

BILGE PUMP

Fishing models may use a bilge pump for filling and recirculating the livewell. Periodically check the bilge pump(s) inlet screens and hoses for obstructions and debris. Foreign materials can clog the screen and hoses or become lodged in the bilge pump impeller, which can cause the pump to malfunction. Periodically check the operation of the bilge pump and float switch, if equipped. Inspect all wiring, clamps and hoses for tightness on a regular basis.

ENGINE

The manufacturer of the boat's engine(s) will provide a separate maintenance procedure. See the *Engine Operator's Manual* for specific information on maintenance procedures.

FUEL SYSTEM

⚠ WARNING *Fire/Explosion Hazard: Gasoline is extremely flammable and highly explosive under certain conditions.*

Be sure to check the fuel hoses and connectors for leaking and deterioration before fueling and on a monthly basis.

Fuel vents are normally located in the deck in the same general area as the fuel fills. Periodically check that the fuel fills and vent lines are free of obstructions and kinks.

Check and/or replace the fuel filter periodically or clean as needed. If the filter has a water separator valve, use a catch container beneath the valve and open the valve to drain the water. Check fuel lines, vent hoses and drain hoses frequently for leaks. Replace any worn or cracked hoses.

Tightening a fitting or clamp may correct a fuel leak. If the leak continues, however, replace the line, fitting or hose immediately to prevent a build-up of fluids or gases.

Use fuel system parts certified for marine use only. Never use automotive parts in marine applications. Modern fuel systems are more complex and should only be serviced by a marine technician certified in fuel systems.

STEERING SYSTEM

⚠ WARNING *Control Hazard: Improper maintenance of steering system is hazardous and can cause death or serious injury from sudden loss of control. Ensure all steering reservoirs, connections, hardware, cables and grease fittings are regularly inspected and maintained. If any steering problems are noticed, do not operate the boat and contact your dealer immediately for service assistance.*

Inspect and maintain the boat's steering system regularly. Frequently check the hardware at the helm, propulsion unit, or rudder end for tightness. See the propulsion *Operator's Manual* or the steering manufacturer's information for the appropriate torques and periodic maintenance.



SECTION 11

GENERAL CARE AND MAINTENANCE

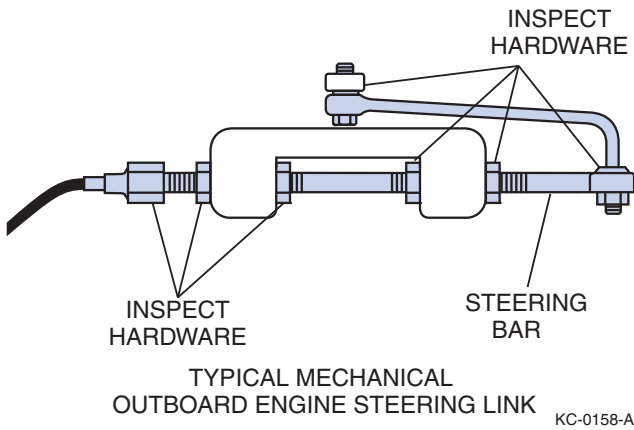

Make sure hydraulic hoses are tight and leak-free. Check cylinder seals for dampness, which indicates leaking. Check the fluid reservoir monthly and top off if necessary. See the steering system manufacturer's information for more details.

TYPICAL HYDRAULIC STEERING SYSTEM

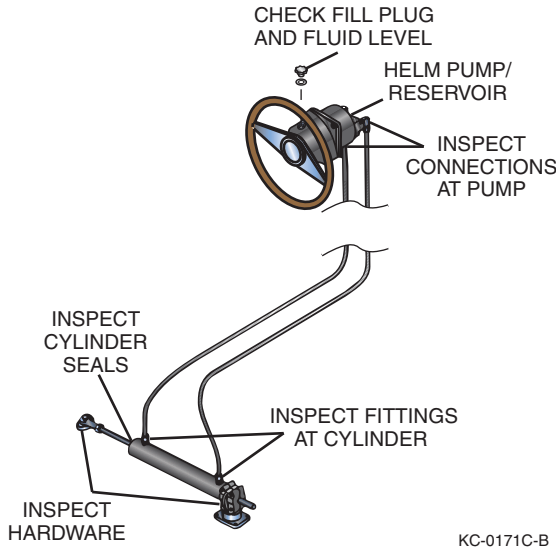

GENERAL CLEANING AND MAINTENANCE

WARNING *Asphyxiation Hazard: Do not mix cleaning agents together; toxic vapors may be released. Read and follow safety-related precautions found on the product labels.*

MARINE GROWTH

If accelerated marine growth is a problem in your area, an antifouling bottom paint may be necessary to slow growth and prevent gelcoat damage. Before selecting a bottom paint, talk to the boat dealer to determine which product works best in your area. Many local variables can affect the selection of paint. Be sure to follow the paint manufacturer's directions exactly.

NOTICE *Marine Growth can significantly inhibit the performance of your pontoon boat.*

CAUTION *When choosing an antifouling or protective bottom paint for your boat's aluminum hull, do not use any paint that contains copper or copper derivatives that may cause galvanic corrosion.*

CLEANING

Never allow any type of cleaning solution or cleaning material to come in contact with the water or be discharged into the water. The discharge of any type of debris or waste, including, but not limited to, food, trash, garbage, oil, fuel, liquids and human waste, is highly restricted, if not unlawful, in most waterways. Never discharge anything into the water.

Periodic cleaning is the best way to keep the boat looking new. Regular washing and waxing keep dirt, algae and water deposits from building up and deteriorating the finish. Keeping the boat in "show room" condition means greater personal satisfaction and higher resale value. Special cleaning products are available from the boat dealer.

PONTOONS

Aluminum pontoons will inevitably oxidize from exposure to the water. It does not matter if your boat sits on a lift or is docked at the pier, you will see some discoloration over time. Although this is normal, you can keep your pontoons looking newer longer by regular cleaning.

Throughout the season while the boat is in the water, it's a good idea to clean the pontoons whenever possible. Use a soft bristle brush or sponge to scrub down the pontoons.



At the end of the season, it's a good idea to thoroughly clean the pontoons before it goes into storage. This can be done with a power washer or just a mild soap and water. **DO NOT USE HARSH ABRASIVES.** If your pontoons have a protective coating on them, it's a good idea to check with the manufacturer of the coating material for their recommendations.

ALUMINUM EXTERIOR PANELS

The best method to clean aluminum panels is to use mild soap and water with a sponge or soft cloth. Mild detergents can be used by diluting 1 cup to 5 gallons of water. Apply with a sponge, soft cloth, or soft bristle brush and be sure to rinse with water right away. Avoid harsh chemicals such as acetone, xylene, gasoline, or anything abrasive.

FIBERGLASS EXTERIOR PANELS

As with the aluminum exterior panels, a mild soap and water yield the best results. Use a soft sponge or soft bristle brush to apply and make sure to rinse well. It's also a good idea to wax the fiberglass pieces every season. Not only will this help keep it clean but also help prevent fading. Overtime, fiberglass will eventually fade but in most cases, it can be buffed and look new again.



VINYL UPHOLSTERY

For normal cleaning, wash vinyl upholstery with a soft cloth or soft-bristles brush lathered with mild, non-abrasive soap and lukewarm water. Before the surface dries, wipe with a clean dry cloth to remove any residue. This procedure may be repeated to remove stubborn dirt or stains. Remove tougher stains with a mild cleaning agent like Fantastic® or Formula 409®.*

Ink spots can sometimes be removed by washing with soap and water, followed by isopropyl alcohol. Indelible inks containing certain dyes used in ball point pens and permanent felt tip markers can leave a shadow if cleaning is delayed more than 24 hours.

NOTICE

Do not use abrasive cleaners or any cleaning method that is not listed above, as other methods may attack the vinyl and cause eventual degradation. Do not use any substance labeled or marketed as a "protectant" or "enhancer" as these substances may contain chemicals that alter the surface characteristics and possibly degrade the polymers.

Certain clothing and accessory dyes (such as denim jeans) may migrate to lighter colors. This phenomenon is increased by humidity and temperature and is irreversible.

To disinfect vinyl surfaces, the CDC recommends a diluted bleach solution (household bleach, at least 1000 ppm sodium hypochlorite) prepared as follows: 1/3 cup bleach per gallon of water. Rinse with fresh water afterward to prevent long-term degradation. Do not spray solution on the vinyl and leave it or just wipe it off. It **MUST** be rinsed or wiped with fresh water to remove residual bleach. Long-term exposure to bleach will accelerate the migration of plasticizers and antimicrobial agents from the vinyl and void the warranty.

NOTICE

Never attempt to clean vinyl, canvas, flooring, or bimini tops with a pressure washer, gasoline, kerosene, or acetone. Do not use a pressure washer on the interior of the boat for any reason or damage will occur.

Although not always convenient, minimizing the boat's contact with damaging ultraviolet (UV) rays and storing removable seats and canopies indoors when not in use will increase the longevity of vinyl upholstery.

NOTICE Covering your boat will extend the life of your furniture and floor, protecting it from UV damage.

NOTICE Sunscreen or suntan lotion can damage vinyl upholstery. Make sure to clean right away with instructions from cleaning guide.

VINYL CARE AND CLEANING GUIDE

TYPE OF STAIN	STEPS:	1	2	3	LEGEND
General care		A	B		A = Medium-soft brush, warm soapy water, rinse/dry
Dirt buildup		A	B		
Ballpoint ink*		B	A		B = 303 Fabric and Vinyl Cleaner®, rinse/dry
Chewing gum		B	A		
Coffee, tea, chocolate		B	A		C = Wipe or scrape off excess (chill gum with ice beforehand)
Grease		C	B	A	
Household soil		A	B		All cleaning methods must be followed by a thorough rinse with clean, warm water. Failure to care for your vinyl properly or use of improper cleaners may void your warranty and damage your vinyl.
Ketchup		A	B		
Latex paint		A	B		
Lipstick		C	A	B	
Mildew or wet leaves*		B	A		
Motor oil		C	B	A	
Oil-based paint		C	B	A	
Permanent marker*		B	A		
Spray paint		B	A		
Suntan lotion*		A	B		
Tar / Asphalt		C	B	A	
Yellow mustard		A	B		

* May leave a permanent stain

Recommended Products

- Mild dish soap
- 303® Fabric & Vinyl Cleaner

Non-Recommended Products

- ArmorAll®
- Bleach
- Baking soda
- Murphy® Oil Soap
- Simple Green®
- STP® Son of a Gun!®

CANVAS COVERS AND BIMINI TOPS

In most cases, boat canvas receives more abuse than any other item on a boat. It's vital to maintain the material to promote longevity. The following guidelines will help you keep your canvas in good condition for years to come.

- If your canvas gets dirty, lay the canvas out and use a mild dish soap, water and a soft broom to remove any dirt. Make sure to rinse thoroughly and allow to dry. Never store a wet canvas.
- Never fold a canvas where creases can form. Always loosely roll canvas to store.
- Never store canvas in plastic bags. Store canvas in a dry, well-ventilated compartment.
- For tougher stains, an automotive convertible top cleaner may be used. Rinse well and allow to dry.
- Never store or dock the boat under trees. Tree sap is very corrosive to canvas and can be harmful to gelcoat and other vinyl materials.
- Always adjust the canvas cover to ensure a tight, taught fit. This will allow for sufficient drainage and prevent pooling. The weight of accumulated rainwater can cause damage or even collapse the cover.
- Lubricate snaps and zippers regularly. Vaseline, silicone spray or paraffin are effective lubricants. Never force snaps and zippers that are stuck.
- Never trailer the boat with the cover on. Always remove, roll and securely store all canvas while trailering your boat to prevent damage.

FLOORING

Newer pontoons have a vinyl weave flooring. This type of flooring is durable and nearly mold resistant. A quick vacuum or rinse down is usually sufficient for most messes. You may also take a leaf blower to clear off loose dirt and debris. A shop-vac is also handy for tight corners and small crumbs.

It's important to make sure to clean up any food particles, especially before storing for the winter. This will help deter animals.



NON-SKID FLOORING

Your boat may use synthetic non-skid material for flooring, swim platform and other stepping surfaces to enhance traction and reduce slips and falls. This material is comfortable underfoot, easy to clean and highly stain resistant. However, as with any product in the marine environment, regular care and cleaning will keep the material looking its best for many years.

Care

Non-skid material is UV protected; however, certain conditions may accelerate fading or damage from the sun, especially on vertical surfaces due to Light Amplification (LA), which can cause sun burning. LA simply means that in addition to direct sunlight, additional sunlight reflected from shiny surfaces such as gelcoat or stainless steel/chrome hardware can be focused on the material and heat it beyond its maximum temperature range. Since sun burning is not covered by your warranty, keep the following points in mind to minimize LA damage:

- Whenever possible, cover the boat/material when kept outdoors.
- Keep objects that can refract light such as pool toys or water bottles off the material as much as possible.
- Consider adding more material to reflective vertical areas that focus on the material.

NOTICE

Covering your boat will extend the life of your furniture and floor, protecting it from UV damage. Fading and discoloration of materials including floors, furniture and helm are considered normal and not covered under the Barletta manufacturer warranty. See Barletta warranty for details.

Cleaning

Regularly clean non-skid material to extend its life. Immediately remove sand, dirt, spills and stains to help avoid drastic cleaning measures. See your dealer for recommended cleaning products and always start with vacuuming loose dirt and sand. Always read the use and safety instructions for cleaning products.

For normal cleaning, spray approved cleaner liberally to cover the affected area. With a medium-bristled boat brush, lightly work the product in. Let the cleaner sit for 3-5 minutes, then use water to dampen the affected area and lightly scrub for a second time. Rinse the cleaner off thoroughly and dry the area with a clean towel.

To clean dirt, footprints, etc., use an all-purpose cleaner, degreaser or dish soap along with warm water and a medium-bristled boat brush. Thoroughly work the soapy mixture into the material. Rinse the area with clean water and repeat if necessary.

To remove suntan lotion, use an all-purpose cleaner or degreaser along with a medium-bristled boat brush. Put small amount of the cleaner on the oil stain and use a medium-bristled boat brush and warm water to scrub until the oil disappears. Rinse the area with clean water and repeat if needed.

To remove fish blood, mix one cup of bleach with one gallon of warm water. Using a soft-bristled boat brush, scrub in a circular motion until the fish blood surfaces. Rinse thoroughly with clean water and repeat if necessary. If not effective, see the following instructions on removing rust stains.

To remove rust stains, use a capful of vinegar or oxalic acid. Apply it to the rust stain and allow it to soak for 3-5 minutes. If necessary, use latex/nitrile gloves to massage the cleaner into the texture of the material. Rinse the area with water and repeat if necessary.

NOTICE

When applying oxalic acid, use care to avoid getting acid on the edges of the material, as it could damage the lamination.

WINDSHIELD

A clean windshield is important. If the boat is equipped with a glass windshield, applying a nonabrasive glass cleaner with a soft cloth will remove most dirt. Clean tinted Plexiglas or plastic windshields with a mild soap solution and damp cloth only. Harsh detergents, solvents, chemicals or dry cloths used on any glass or plastic windshield will scratch the surface.

MOORING AND TRAILERING COVERS

A mooring cover is typically a lightweight nylon cover used when the boat is moored or docked on the water and that can be quickly fitted on the boat. A trailering cover is a heavier canvas and can be securely fastened to the boat/trailer for highway use. Both types cover the entire boat and offer protection from sun, wind and rain. In most cases, boat covers receive more abuse than any other item on a boat due to exposure to the elements.

Covers should be regularly maintained for long life and top performance. Moisture, dirt, chemicals from industrial fallout, heat, ultraviolet rays, tree sap and salt water can all contribute to the deterioration of covers.



Covers are recommended to protect your investment; the following guidelines will help you keep your covers in good condition:

NOTICE

- Always follow any written maintenance instructions from the cover manufacturer.
- Only use Barletta Total Eclipse Cover for trailering. Other Barletta “clip-style” covers that cover the playpen area only are not to be used for trailering or damage may occur to boat and/or cover. Only covers specifically mentioned as “trailering” are acceptable for travel.
- No cover can be used for winter storage.
- Never store or dock the boat under trees. Tree sap is very corrosive to covers and can also be harmful to gelcoat and vinyl interiors.
- Adjust cover top bows/poles to eliminate pockets in which rainwater can accumulate. The weight of accumulated water can collapse or damage the cover. Poles should be extended to maximum height possible.
- Wet canvas must be allowed to dry thoroughly before storage.
- Covers can be cleaned with a soft scrub brush and either automotive convertible top cleaners or household cleaners suitable for use on vinyl surfaces. The underside of the cover may be periodically sprayed with a spray disinfectant to prevent mildew.

STAINLESS STEEL AND CHROME HARDWARE

Stainless steel and chrome will normally oxidize over time, especially in marine environments. Cleaning and preventive maintenance of stainless steel and chrome hardware are crucial in maintaining appearance and functionality. If the hardware is left unattended, it can corrode, causing the hardware to appear unsightly and cause structural integrity problems.

Wash the stainless steel and chrome hardware with mild soap and water after operating the boat in corrosive environments such as salt water.

Remove rust or corrosion promptly by cleaning the hardware using a high-quality stainless steel, chrome cleaner or conditioner. Do not use any abrasive materials such as steel wool or sandpaper to clean the hardware. Do not use acids or bleach or any cleaners not intended for stainless steel or chrome, such as glass, tile or counter cleaners, as these types of cleaners can cause permanent damage. Always test a cleaner in an inconspicuous area first before applying to the complete surface.

After cleaning, protect the surface of the hardware by using a high-quality boat, automotive, stainless steel or chrome protectant or wax.

ALUMINUM HARDWARE

Periodically wash aluminum hardware with soap and water to keep it clean. If the boat is used in salt water or polluted water, wash aluminum hardware with soap and water after each use. Salt water allowed to remain on aluminum will penetrate the metal and corrode the aluminum.

It is recommended to frequently clean and coat all aluminum hardware with a metal protectant made for aluminum to protect against pitting and corrosion caused by the harsh effects of salt water. Choose an appropriate cleaner specific to your needs, as special cleaners are available for different types of aluminum hardware such as anodized, powder coated and polished.

Most stains can be removed from aluminum with a metal polish or fine polishing compound. To minimize corrosion, use a caulking compound or Teflon-based sealer to isolate hardware and fasteners mounted to aluminum fabrications. With proper care, aluminum hardware can provide many years of service.

TRAILER

Periodically check the general trailer components for damage, general condition and operation when applicable. Always replace trailer components that are in question or in need of repair.

- Lights
- Electrical connectors
- Tires (condition and pressure)
- Wheel lug nuts and studs
- Wheel valve stems
- Wheel bearings
- License plate and holder
- Rollers, bunks and hardware
- General fasteners (missing, loose or corroded)
- Safety chains or straps
- Winch, winch strap and hooks
- Trailer coupler and latch
- Frame, axle and springs
- Spare tire and wheel
- Brakes and actuator assembly

Section 12

WINTERIZATION AND STORAGE

The boat may be equipped with a variety of specialized systems and components. The following basic and typical information may not apply to your specific application. This section may not cover all systems or components on the boat. Consult the boat dealer for assistance.

Winterizing or storing the boat for extended periods of non-use requires special preparation to prevent boat and system damage. Without proper preparation, if the boat is not used or is stored for extended periods of time, internal parts of the engine may become corroded from lack of lubrication. If the boat is stored in freezing temperatures, water inside the bilge, engine cooling system or boat water systems may freeze and cause damage. Be sure to keep up with all annual maintenance during winterization.

Before performing any winterization and storage procedures within this section, review *Safety in Section 2*.

LIFTING

NOTICE Consult the boat dealer for proper preparation and lifting instructions for the boat.

Attempt to lift or hoist boats only if you are qualified or experienced with this procedure. This procedure requires special equipment and experience. Do not attempt to lift or hoist the boat alone; damage, personal injury or death can occur.

WARNING *Crush Hazard: Special equipment is necessary to lift the boat and/or engine. Always use undamaged lifting equipment with sufficient capacity to lift the boat and/or engine.*

Empty water and water tanks and winterize applicable systems prior to removing the boat from the water. Consult the information for propulsion, water, waste, air conditioning and fuel systems before removal from the water. Improper winterization, lifting and storage is not covered by the warranty.

If the boat is to be removed from the water without a trailer, follow these guidelines:

- Cover lifting cables with a rubber hose or other protectors to prevent damage to the finish.
- Attach guidelines to the bow and stern to control movement.
- Use spreader bars and keep lifting pressure vertical to prevent side load damage.
- Keep the bow slightly higher than the stern to prevent engine damage.

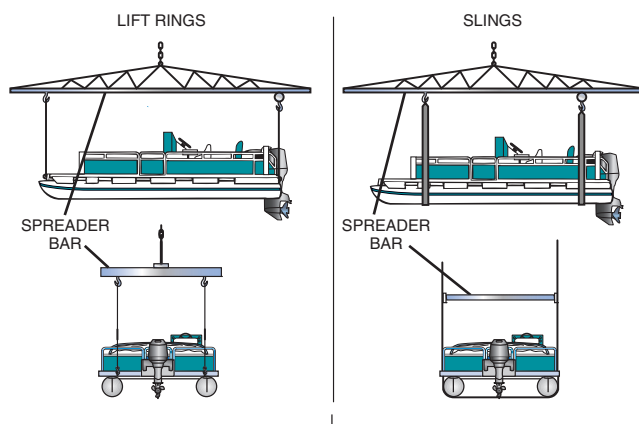

KC-0313C-A

WINTERIZATION AND STORAGE PREPARATION

The following procedures will help prevent damage to the boat:

- While the boat is still in the water, add the proper amount of fuel stabilizer/ conditioner according to the engine manufacturer's recommendations. If the boat contains fuel with ethanol, pump-out as much as possible before removing the boat from the water. Operate the boat for at least 15 minutes to be sure that the treated fuel has reached the engine.

NOTICE *If you plan to store the boat for more than three months in either a humid environment, extreme temperatures or outdoors, "fog" the engine with a corrosion-preventing fogging oil according to the propulsion system manufacturer's recommendations. See the Engine Operator's Manual for more information.*



WINTERIZING – CLEANING

- When performing the winterization process on a Barletta Pontoon Boat, it's important to pay special attention to certain items. Some are specific to Barletta Boats, and some are industry wide practice. This section will help guide you through the process and make sure to keep your Barletta looking and operating like new.
- If you don't get all the water out of the engine, you could face a cracked block once the water freezes and this will ruin an engine in no time flat. There are other components in the engine that should be addressed at this time as well. This is an opportune time to have an oil change performed and any other items addressed so that your boat is water ready once the warm weather returns. Please consult with your local dealer about having your engine winterized professionally. If using shrink wrap, be sure to cut a relief in the shrink wrap at the lowest point on the engine. Water can accumulate and in freezing climates can cause engine damage. Cut a slit at the lowest point, being careful not to scratch the paint.
- Winterizing the interior is also important. Make sure all the trash is removed from the interior of the boat and the pet dishes are clean to prevent pests. Give the seats, flooring, and helm a good cleaning with a vacuum. Remove all items such as life jackets, towels, and other items that could mold. Once everything is removed and vacuumed, you can use a soft bristle brush with soap and water to wash everything down. Make sure to leave the seat benches open to allow drying before you cover.
- Be sure to pay attention to the storage/cooler compartments as well. Start by opening the cooler storage and removing all personal items and debris, then remove the mesh mat. Locate the 3 Phillips head screws securing the rear aluminum plate in the compartment and remove them using a #2 Phillips head bit. Inspect for water in the compartment and remove all debris in and around the bilge pump. Use a wet/dry



vacuum to completely empty the compartment. It is highly recommended that you pour ½ gallon or more of -100 F biodegradable antifreeze into the pump well and run the pump until the fluid coming out of the discharge is pink.

- Also make sure to give the exterior a good cleaning, including the pontoons. Marine growth left for long period of time can cause serious damage. Soapy water and a soft bristle brush works great on the pontoons. Make sure to get into all the nooks and crannies to remove any leftover seaweed and debris. Take a soft cloth and soapy water to wipe down the rails and side panels.

STORING ON A CRADLE OR BLOCKS

- When storing a boat on support other than the proper trailer, make sure the hull is supported properly to prevent hull damage. Most cradles are custom-built to support the boat's hull.
- Put the cradle, stands or blocks on a hard, level surface capable of supporting the combined weight of the cradle and the boat.
- When using blocks with jack stands, always use jack stands that are rated for more than the required load, making sure they are securely positioned so they cannot move under the load. Use a minimum of three blocks to support the keel and each side of the boat where applicable. Use a minimum total of nine jacks and/or blocks.

If stored outside:

- Position the boat to allow for adequate draining from rain or snow.
- Cover the boat to prevent the collection of rain, snow or debris. When using a cover, allow ventilation for residual moisture and condensation to escape. Never cover or plug the bilge drain hole.

NOTICE

Mooring covers are not designed to be used to protect the boat when stored outside. Use a high-quality, properly fitted canvas cover with suitable support for expected snow loads.

- Position the lower unit drive in the DOWN position.



STORING ON A TRAILER

- Be sure the trailer supports are adjusted to properly support the boat's hull.
- Park the trailer and boat in a protected area with the lower unit drive in the DOWN position.
- Loosen tie-downs and winch line, but be sure the boat is resting properly on hull supports.
- Lift the trailer and place blocks under the trailer frame to relieve weight on trailer tires and springs. Position the boat to allow for adequate draining from rain or snow.
- Cover the boat to prevent the collection of rain, snow or debris. When using a cover, allow ventilation for residual moisture and condensation to escape. Never cover or plug the bilge drain hole.

STORING DURING THE SUMMER

The best way to store your boat is under a boat house or storage roof. A mooring cover will help reduce the effects of sun and dirt. The mooring cover can repel most water but will collect water during heavy downpours. Always remove collected water after a rain to help prevent tearing and staining. The mooring cover can suffer damage from high winds, so take proper precautions to prevent damage when possible. If you desire a canvas cover that can also withstand heavier loads, contact your dealer to get information on a custom storage cover from a local canvas maker.

RECOMMISSIONING AFTER STORAGE

- Check tire pressure and lug nut tightness on the trailer.
- Inspect the hull for damage.
- Charge and install all batteries.
- Remove blocks from under the trailer frame.
- Tighten tie-downs and the trailer winch line.
- Check the bilge blower vents for obstructions and blower operation.
- Check the bilge pump and float switch for proper operation.
- Inspect all battery and electrical wiring for loose connections and/or damage.
- Check the fuel system for leaks or damage. Verify the condition of all hoses and fuel line. Should a fuel hose need replacing, use only USCG-approved hose. Check hose labels for exact type of replacement. Be sure all hose clamps are tight.

- Check the engine and bilge for signs of nesting animals; clean as necessary.
- Check the entire engine for cracks and leaks caused by freeze damage.
- Check the condition of all hoses and clamps for tightness.
- Clean the bilge area and install the boat bilge drain plug.
- Lubricate all seacocks and check for proper operation.
- Install all drain plugs in strainers and seacocks.
- Close all drains and valves that were opened during winterization.
- Perform any annual maintenance not performed during winterization. See the propulsion and equipment manufacturer's information for periodic and annual maintenance procedures.
- Check all raw water intake areas and screens for obstructions.
- Check and lubricate the steering system.
- Check all navigational lights.
- Check all controls, gauges, boat systems, accessories and related equipment for proper operation.
- Check all fire extinguishers for charge level and expiration date.
- Inspect all safety equipment for condition and operation as applicable.
- Add fuel to the fuel tank. Add only enough for one week.
- When possible, briefly start and run the engine(s) using proper water supply equipment to check that the engine does start and there are no major operational problems.

NOTICE

If fogging oil was used during winterization, the engine will emit excessive white smoke upon initial start-up. This condition is normal and will diminish once the fogging oil has been cleared through the engine.

- Once the boat is in the water, start the engine.
- Start the engine(s) and watch the gauge readings closely, checking for leaks and abnormal noises.
- Keep speeds low for the first 15 minutes until the engine has reached normal operating temperature.
- See the *Engine Operator's Manual* and all equipment manufacturer's information for additional recommendations.



SECTION
12

WINTERIZATION AND STORAGE

This Page Intentionally Left Blank

Section 13

TROUBLESHOOTING

The following information will assist you in identifying basic performance, mechanical and electrical problems. This information is intended as a general troubleshooting guide and may describe items that are not applicable to the boat.

The tachometer can be very useful when troubleshooting the boat's performance problems. A typical engine should maintain the same operating rpm throughout the useful life of the boat. When the normal

operating rpm is known, that rpm should be used as a starting point when performance problems arise.

If you detect a problem with the engine, see the *Engine Operator's Manual*. If you detect an equipment or boat system problem, see the manufacturer's information for that item.

Before performing any troubleshooting procedures within this section, review *Safety in Section 2*.

NOTICE *Certain problems may require specialized skills and tools. Always consult qualified personnel before making any repairs or modifications.*

PROBLEM	POSSIBLE CAUSES
Engine will not crank	<ul style="list-style-type: none"> • Engine cut-off switch lanyard not connected • Shift/throttle control not in the NEUTRAL position • Battery switch is in the OFF position • Main circuit breaker open • Battery terminals or wiring connections corroded • Low battery voltage • Faulty ignition switch/FOB battery dead • Engine problem
Engine cranks but will not start	<ul style="list-style-type: none"> • No fuel in tank • Fuel tank valves closed to engine • Fuel filter clogged • Flame arrestor dirty, if equipped • Contaminated fuel • Engine problem
Poor boat performance	<ul style="list-style-type: none"> • Improper power trim position • Improper trim tab position • Uneven load distribution • Excessive load • Contaminated fuel • Improper propeller selection • Excessive water in bilge • Damaged or obstructed propeller • Marine growth on hull • Damaged hull • Plugged flame arrestor, if equipped • Engine system problem
Throttle/shifting control problems	<ul style="list-style-type: none"> • Corroded cable • Excessive bends or kinks in cable • Engine/network system problem
Excessive vibration	<ul style="list-style-type: none"> • Damaged or obstructed propeller • Bent propeller shaft • Engine/network system problem



PROBLEM	POSSIBLE CAUSES
Electrical problems	<ul style="list-style-type: none">• Blown fuse/breaker or open circuit• Loose or corroded wiring connections• Defective switch or gauge• Weak or discharged battery• Loose shore power connection
Erratic or no speedometer reading	<ul style="list-style-type: none">• Disconnected, kinked or plugged pickup tube or pitot• Speedometer gauge faulty

Section 14

GLOSSARY OF NAUTICAL TERMS

ABOARD – On or in the boat.

ABYC – American Boat and Yacht Council, Inc.

AFLOAT – On the water.

AFT – Toward the rear or stern of the boat.

AGROUND – Touching bottom.

AMIDSHIP – Center or middle of the boat.

ANCHOR – (1) An iron casting shaped to grip the lake bottom to hold the boat.

(2) The act of setting the anchor.

ASHORE – On the shore.

ASTERN – Toward the stern.

AUTOMATIC CHARGING RELAY (ACR) – An ACR parallels (combines) batteries during charging, and isolates them when charging has stopped and after battery voltage has fallen. An ACR is intended to keep a load from discharging both of the batteries.

AUTOMATIC IDENTIFICATION SYSTEM (AIS) – An automatic tracking system used on ships and by vessel traffic services (VTS) for identifying and locating vessels by electronically exchanging data with other nearby ships, AIS base stations, and satellites.

BAIL – To remove water from the bottom of the boat with a pump, bucket, sponge, etc.

BAITWELL – A miniature livewell used to store and keep live bait alive and healthy.

BEAM – The widest point on the boat.

BEARING – Relative position or direction of an object from the boat.

BILGE – The lowest interior section of the boat hull.

BILGE KEELS – The raised areas or aluminum extrusions on the bottom of a boat that parallel the keel.

BOARDING – To enter the boat.

BOUNDARY WATERS – A body of water between two areas of jurisdiction; i.e., a river between two states.

BOW – The front of the boat.

BULKHEAD – Vertical partition (wall) in a boat.

BUNKS – Hull supports on trailer that may be covered with carpet, plastic or rollers.

BURDENED BOAT – Term for the boat that must “give-way” to boats with the right-of-way.

CAPACITY PLATE – A plate that provides maximum weight capacity and engine horsepower rating information. It is located in full view of the helm.

CAPSIZE – To turn over.

CAST-OFF – To unfasten mooring lines in preparation for departure.

CENTER LINE – A lengthwise imaginary line which runs fore and aft with the boat’s keel.

CHINE – The point on a boat where the side intersects (meets) the bottom.

CLEAT – A deck fitting with ears to which lines are fastened.

CONSOLE – Also called helm. The steering wheel area of the boat.

CONTROLLER AREA NETWORK (CANBUS) – A robust bus standard designed to allow microcontrollers and devices to communicate with each other in applications without a host computer.

CRANKING BATTERY – The main battery used for engine starting and electrical circuits.

CURRENT – Water moving in a horizontal direction.

DECK – The open surface on the boat where the passengers walk.

DEEP-CYCLE BATTERIES – Special long-running batteries which can be repeatedly discharged and recharged without significant loss of power.

DIGITAL SELECTIVE CALLING (DSC) – A standard for sending pre-defined digital messages via the medium frequency (MF), high frequency (HF) and very high frequency (VHF) maritime radio systems. It is a core part of the Global Maritime Distress and Safety System (GMDSS).

DOLLY WHEEL – A rolling jack assembly at the front of the trailer used for positioning the coupler during trailer hookup.

DRAFT – The depth of the boat below the waterline, measured vertically to the lowest part of the hull.

ELECTRONIC LEAKAGE CIRCUIT INTERRUPTER (ELCI) – Installed with or in addition to the main shore power disconnect circuit breaker(s) to offer an additional level of protection from shore power faults.

ELECTRONIC NAUTICAL CHARTS (ENCs) – Vector data sets that support all types of marine navigation.

ELECTROLYSIS – The breakup of metals due to the effects of galvanic corrosion.

EMERGENCY POSITION INDICATING RADIO

BEACONS (EPIRBs) – Safety devices carried by a vessel to alert search and rescue services and allow them to quickly locate you in the event of an emergency.

FATHOM – Unit of depth or measure; 1 fathom equals 6 feet.

FENDERS – Objects placed alongside the boat for cushioning. Sometimes called bumpers.

FORE – Toward the front or bow of the boat. Opposite of aft.

FREEBOARD – The distance from the water to the gunwale.

FUEL SENDING UNIT – The electrical device that is mounted on the outside of a built-in fuel tank and controls the dashboard fuel gauge.

GIVE-WAY BOAT – (1) Term for the boat that must take whatever action necessary to keep well clear of the boat with the right-of-way in meeting or crossing situations. (2) The burdened boat.

**GLOBAL MARITIME DISTRESS AND SAFETY**

SYSTEM (GMDSS) – An internationally agreed-upon set of safety procedures, types of equipment, and communication protocols used to increase safety and make it easier to rescue distressed ships, boats and aircraft.

GLOBAL POSITIONING SYSTEM (GPS) – A global navigation satellite system that provides geolocation and time information to a GPS receiver.

GROUND FAULT CIRCUIT INTERRUPTER (GFCI) – A type of circuit breaker that measures current flow in the hot and neutral wires and immediately switches the electricity off if an imbalance of current flow is detected.

GUNWALE – The rail or upper edge of a boat's side.

HEAD – A marine toilet.

HELM – The steering wheel or command area.

HULL – The body of the boat.

HYPOTHERMIA – A physical condition where the body loses heat faster than it can produce it.

IN-LINE FUSE – A type of protective fuse located in the power wire of a direct current (DC) circuit usually near the battery.

KEEL – The lowest portion of the boat; extends fore and aft along the boat's bottom.

LIFE JACKET – A buoyant, wearable jacket that, when properly used, will support a person in the water; also see PFD.

LIST – Leaning or tilt of a boat toward the side.

MAKING WAY – Making progress through the water.

MARINE CHART – Seagoing maps showing depths, buoys, navigation aids, etc.

MOORING – An anchor, chain or similar device that holds a boat in one location.

NATIONAL MARINE ELECTRONICS ASSOCIATION (NMEA) – A U.S.-based marine electronics trade organization setting standards of communication between marine electronics.

NATIONAL OCEANIC AND ATMOSPHERIC ADMINISTRATION (NOAA) – An American scientific agency within the United States Department of Commerce that focuses on the conditions of the oceans, major waterways and the atmosphere.

NAVIGATION AID – Recognizable objects on land or sea such as buoys, towers or lights which are used to fix position to identify safe and unsafe waters.

NEMA 2000 – A plug-and-play CANBUS communications standard used to connect marine instruments and engines within the vessel for integrated data exchange.

NMMA – National Marine Manufacturers Association.

NO-WAKE SPEED – The speed at which a boat travels to produce an imperceptible wake.

PASSIVE HYDROLOCK – A problem that occurs when water siphons through the boat's exhaust system, enters a cylinder in the engine and results in an engine starting failure. This problem is possible on any marine vessel powered by a combustible engine with exhaust risers that sit below the waterline.

PFD – A buoyant personal flotation device used to support a person in the water; also see Life Jacket.

PITOT TUBE – See Speedometer Pickup Tube.

PLANING HULL – A hull designed to lift, thereby reducing friction and increasing efficiency.

PORPOISE – A condition in which the bow bounces up and down caused by trimming the engine too far out.

PORT – (1) The left side of a boat when facing the bow. (2) A destination or harbor.

PRIVILEGED BOAT – Term used for the boat with the right-of-way.

PULPIT – The fiberglass extension on the bow of the boat used as a place to secure your anchor.

RIGHT-OF-WAY – Term for the boat that has priority in meeting or crossing situations. The stand-on or privileged boat.

RULES OF THE ROAD – Regulations for preventing collisions on the water.

SPEEDOMETER PICKUP TUBE – Also called pitot tube. The plastic device that extends below the bottom of the boat. It connects to the speedometer with plastic flexible tubing.

SPLASHWELL – The section of an outboard-equipped boat that is just forward of the transom.

STAND ON BOAT – Term for the boat that must maintain course and speed in meeting or crossing situations. The privileged boat.

STARBOARD – The right side of the boat when looking toward the bow.

STERN – The back of the boat.

STOW – To pack the cargo.

STRONG POINT – A dedicated eye specially reinforced for the attachment of mooring lines, anchor chains, anchor lines and tow lines.

SURGE BRAKES – A type of trailer braking system designed to automatically actuate when the tow vehicle's brakes are applied.

TRANSDUCER – The unit that sends/receives signals for the depth sounder.

TRANSOM – The transverse beam across the stern.

TRIM – Fore to aft and side to side balance of the boat when loaded.

UNDERWAY – Boat in motion; i.e., not moored or anchored.

USCG – United States Coast Guard.

V-PAD – A modified vee-hull design with a small, flat area in the keel aft.



VISUAL DISTRESS SIGNAL – A device used to signal the need for assistance such as flags, lights and flares.

WAKE – The waves that a boat leaves behind when moving through the water.

WATERWAY – A navigable body of water.

WINDLASS – A mechanical device that grasps the anchor line or chain to raise or lower the anchor.



SECTION

14

GLOSSARY OF NAUTICAL TERMS

This Page Intentionally Left Blank

INDEX

Numerics

5-pin wiring connector 10-3

A

About this manual 1-1
About this section 7-1
About your new boat 1-3
Accelerating and running underway 9-8
Accessory ports 8-4
Accidents 3-2, 4-4
Accidents, collisions and giving assistance 4-4
Aesthetic and branding 8-8
After refueling 9-6
Aids to navigation 6-2
Alcohol 3-2
Alignment on right panel 7-10
Aluminum exterior panels 11-9
Aluminum hardware 11-12
Aluminum pontoons and hulls 11-3
America's waterway watch 3-3
American Boat & Yacht Council 1-5
American Red Cross 1-5
Anchor line 9-12
Anchors and anchoring 9-12
Anodes 11-2, 11-4
Antifouling bottom paint 11-8
Aquatic Invasive Species (AIS) 3-4
Aquatic vegetation/weeds 5-2
Arch operation 8-9
Aria 7-11
Arrangement on left panel 7-10
Audible (sound) signals 2-14
Audible signaling devices 2-8, 2-14
Audible signals 6-2

B

Backing up 10-6
Barletta coastal edition 8-7
Barletta safety tags 2-3
Basic safety rules 2-1
Batteries 11-5
Battery 8-1, 8-4
Battery isolators 8-1
Battery switch 8-4
Before getting underway 9-1
Before refueling 9-5
Bell 6-2
Bilge pump 11-7
Bilge system 11-7
Bimini boot 8-10
Bimini options 8-9
Boarding 9-2
Boat features and options 8-1
Boat flags 5-3

Boat information form 1-7
Boat loading 9-2
Boat owner / operator responsibilities 3-1
Boat Owners Association of The United States ... 1-5
Boat system failure 4-4
Boat terminology 1-3
Boating accident 3-2
Boating equipment 11-2
Boating regulations and your responsibilities . 1-i, 3-1
Boating under the influence 3-2
BoatU.S. Foundation for Boating Safety
Hotline 1-6
Bridges and shipping channels 3-3
Bunk-style trailer 10-1
Buoys 6-2, 6-3, 6-4, 6-5, 6-6, 6-7, 6-8
Button arrangement on console 7-13

C

Cabana enclosures 9-12
Cabrio 7-8
Canvas covers and bimini tops 11-10
Capacity plate 9-2
Capsizing and flooding 4-3
Carbon monoxide (CO) 2-6, 2-20
Certification standards 1-4
Charging system 8-1
Checks after operation 9-9
Circuit breakers and fuses 11-6
Cleaning 11-8
Cleaning agents 3-5
Cold water 5-1
Cold weather 5-1
Collision 4-4
Commercial shipping safety zones 3-3
Communication equipment 4-1
Compass 8-4
Compliance plate 1-4
Control operation guidelines 7-14
Corrosion protection 11-2
Corrosion protection and durability 8-7
Corsa 7-6
Corsa arch 8-10
Covering 9-12
CPR 4-1
Crossing 6-1
Cruising limitations 2-19

D

Dams and spillways 5-2
Danger signal 6-2
Dangerous weather 4-4
Daymarks/Dayboards 6-3, 6-5
DC system 8-1
Debris 5-2

Design category 1-5
 Designated occupant seating 2-24
 Diameter 8-3
 Disclaimer 1-5
 Distress signaling devices 4-1
 Distress signals 6-2
 Docking 9-11
 Double bimini 8-10
 Driving defensively 2-18
 Drugs 3-2

E

Easy dock thruster system 7-15, 8-5
 Electric power assist steering 8-2
 Electric supply 8-1
 Electrical system 8-1, 11-5
 Electrolysis 11-2
 Emergencies 4-1, 4-4
 Emergency assistance 3-2
 Emergency preparation checklist 4-1
 Emissions 3-5
 Engine 11-7
 Engine cut-off switch and link 2-9, 7-16
 Engine-transom support bracket 10-3
 Exhaust emissions 3-5

F

Fasteners 11-5
 Fiberglass exterior panels 11-9
 Fire and explosion 4-2
 Fire extinguisher 2-8, 2-9
 Fires 2-9
 First aid/medical emergencies 4-1
 Fishing 3-3
 Fishing models 8-6
 Fishing seats 8-7
 Flags 5-2, 5-3
 Float plan 9-1
 Flooring 11-10, 11-11
 Fog conditions 5-1
 Freezing temperatures 5-1, 12-1
 Fuel (gasoline) 9-4, 11-7
 Fuel burning appliances 8-5
 Fuel level gauge 8-4
 Fuel management 9-3
 Fuel suppliers 9-3
 Fuel system 8-1, 11-7
 Fuel filter 11-7
 Fuel tanks 8-1
 Fueling 7-4, 9-3, 9-4
 Full down position – lifts/bridges/storage 8-9
 Full open position – maximum shade 8-8
 Fuses 11-6

G

Galvanic corrosion 11-2
 Gauges 8-3
 Gauges/Instruments 8-3
 General cleaning and maintenance 11-8
 General operation of fuel-burning appliances 8-6
 Getting underway 9-6
 Glossary of nautical terms 14-1
 Gross Vehicle Weight Rating (GVWR) 10-1

H

Harbor flags and indicators 5-3
 Hardware, fasteners and fittings 11-5
 Hazard 2-3, 5-1, 5-2
 Hazard information 2-19
 Helm 9-6
 Helm and control switches 8-4
 Helm and Controls 7-1
 Helm and controls 7-1
 High-speed multi-engine operation
 considerations 9-9
 Hitch ball and trailer coupler 10-2
 Horn 6-2
 Hour meter 7-15
 Hull identification number 1-4
 Hull identification, capacity and safety plates 1-4
 Hurricane and severe weather preparedness 4-5
 Hydraulic steering 8-2
 Hypothermia 4-1, 5-1

I

Icy waters 5-1
 Important items to note about your new
 Barletta 1-1
 Inclement weather 5-1
 Insurance 3-1
 Isolated danger markers 6-8

J

JBL powered rallybar option and operation 8-9

K

Knowing the boat 2-18

L

Lateral markers 6-5
 Launching 10-6
 Law of salvage 4-5
 Legal considerations 10-1
 Life jackets 2-8, 2-9, 11-1
 Lifting 12-1
 Lighthouses 6-4
 Lights and lighted structures 6-3
 Lines and knots 9-14
 Loading guidelines 10-7
 Lusso and Lusso twin engine 7-3



Lusso arch 8-10
 Lusso single engine 7-5
 Lusso twin engine 7-4

M

Maintenance 11-1
 Man Overboard (MOB) 4-3
 Manatee 6-6
 Marine Assistance Request Broadcast (MARB) ... 4-2
 Marine growth 11-8
 Markers 6-2, 6-4, 6-6
 Markers, warnings and advisories 5-2
 Mayday 4-1
 Mechanical steering 8-2
 Medical emergencies 4-1
 Meeting head-on 6-2
 Mercury joystick 7-4
 Minor lights 6-3, 6-5
 Minors 3-2
 Monofilament fishing line 3-4
 Mooring 9-12
 Mooring and trailering covers 11-11
 Mooring buoys 6-3
 Motor pod 11-7
 Multi-gauges 8-3

N

National Association of State Boating Law
 Administrators 1-6
 National Marine Manufacturers Association 1-6
 National Oceanic and Atmospheric
 Administration's National Weather Service 1-6
 National Safe Boating Council Inc. 1-6
 Nautical terminology 1-3
 Naval vessel protection zones 3-3
 Navigation locks 6-2
 Navigation markers 5-2
 Navigation rules and aids 6-1
 Navigational lights 2-15
 Navigational lights and night operation 6-9
 Negligent operation 3-3
 Neutral start safety switch 7-14
 Noise 3-4
 Non-skid flooring 11-11

O

Observer 2-21
 Operating in hazardous conditions 5-1
 Operating under the influence 3-2
 Operation by minors 3-2
 Operator's license and education 3-2
 Organizations 1-5
 Other special signs and markers 6-6
 Overtaking/passing 6-2

P

Paints 3-5
 People with handicaps and elderly people 2-18
 Performance 9-2
 Performance and versatility 8-8
 Performance operation 9-10
 Personal location beacon (PLB) 2-17
 Pets 2-19
 Pitch 8-3
 Planing 9-8
 Platform dragging 2-20
 Pontoon boat considerations 10-5
 Pontoons 11-8
 Portable cupholders 1-ii
 Power assist steering 8-2
 Power bimini top instructions for proper
 operation 8-8
 Power trim 9-9
 Power trim and tilt 9-9
 Pre-departure safety checklist 9-1
 Preferred channel markers 6-7
 Pregnant women 2-18
 Propane gas grill 8-6
 Propeller selection and replacement guidelines ... 8-3
 Propellers 8-3
 Proper operation 8-8, 8-9
 Protecting the boat from theft 4-6
 Protecting the environment 3-4
 Publications 1-5

R

Radar position – rear entry/exit 8-9
 Range lights 6-4
 Range markers 6-4
 Recommended safety equipment 2-16
 Reduced visibility 5-1
 References and contact information 1-5
 Refueling 9-5, 9-6
 Refueling built-in fuel tanks 9-6
 Registration 3-1
 Registration certificates 3-1
 Registration numbers 3-1
 Regulations 3-2, 3-4, 3-5, 6-1
 Regulatory markers 6-4
 Reporting accidents 4-4
 Reporting safety defects 10-7
 Requesting assistance (non-distress call) 4-2
 Required boating safety equipment and
 regulations 2-8
 Reserve Leggera 7-1
 Restricted areas 3-3
 Right-of-way 6-1
 Rotational thrust 9-7
 Rules of the road 6-1

Running aground 4-3

S

Sacrificial anodes 11-4
 Safe water markers 6-6
 Safety 2-1, 3-1, 9-2
 Safety chains 10-3
 Safety equipment 9-1, 11-1
 Safety guidelines 2-1
 Safety labels 2-3
 Safety precautions 2-4
 Safety standards 1-4
 Safety statements 2-3
 Saltwater corrosion 11-2
 Maintenance 11-3
 Saltwater ready construction 8-7
 Scissor-style trailer 10-1
 Sea Tow Services International, Inc. 1-6
 Seals in the engine lower unit 3-4
 Seating 2-24
 Security zones 3-3
 Severe weather 5-1
 Shallow water 5-2
 Shallow water boat stability 3-4
 Shallow water operation 5-2
 Shift and throttle controls 7-14
 Shifting 9-7
 Shock 5-1
 Show lighting 2-15
 Signs 6-6
 Single-lever controls - single or twin engine 7-14
 Situational awareness 2-17
 Small boats and swimmers 2-18
 Special markers 6-4
 Special needs passengers 2-18
 Speed 3-4
 Speed limits 3-4
 Spillways 5-2
 Sport bimini 8-10
 Spotter 2-21
 Stainless steel and chrome hardware 11-12
 Standard bimini 8-9
 Starting 9-6
 Static electricity and the fuel system 9-3
 Steering 9-6
 Steering system 8-2, 11-7
 Stopping 9-7
 Storage 12-2, 12-3
 Storing 12-1
 Storm conditions 5-1
 Storm warning 5-3
 Strong points 1-3
 Summer storage 12-3
 Surge brakes 10-3

Switch column left of wheel 7-7
 Switch column right of wheel 7-7
 Switches 8-4

T

The general prudential rule 6-1
 Toddlers 2-18
 Towing hitch 10-2
 Towing on the water 4-4
 Towing vehicle 10-1
 Trailer 10-1, 11-12
 Trailer brakes 10-3
 Trailer classification 10-1
 Trailer gross vehicle weight rating 10-1
 Trailer regulations 10-1
 Trailer type 10-1
 Trailering and launching 10-1
 Trailering guidelines 10-3
 Trim / tilt gauge 7-15
 Trim / tilt switch 7-15
 Type B fire extinguishers 2-9

U

U.S. Coast Guard (USCG) 1-6, 3-1
 U.S. Coast Guard Auxiliary 1-6
 U.S. Coast Guard Navigation Center
 (NAVCEN) 1-6
 U.S. Coast Guard Office of Boating Safety 1-6
 U.S. Coast Guard safety standards compliance
 plate 1-4
 U.S. Coast Guard's America's Waterway
 Watch Program 1-6
 U.S. Government Publishing Office 1-6
 U.S. Power Squadrons 1-6
 United States Aids to Navigation System
 (USATONS) 6-2
 USCG safety standards 1-4
 Using distress signals 4-1
 Using the boarding ladders 9-2

V

Vari-pitch position – shade during low sun 8-8
 Vegetation 5-2
 Vehicle towing hitch 10-2
 Very high frequency (VHF) radio 2-2, 2-17
 Vinyl care and cleaning guide 11-10
 Vinyl upholstery 11-9
 Visibility 5-1
 Visual distress signaling (VDS) devices 2-8, 2-13
 Visual distress signals (VDS) 2-14
 Voltmeter 7-15

W

Wake 3-4
 Waste management plan (WMP) 3-4
 Water hazards 5-1



Water sports 2-19
Water sports and towing safety 2-25
Water sports guidelines 2-20
Water sports responsibility code 2-26
Water sports tips 2-28
Weather 4-4
Whistle 6-2
Windshield 11-11
Winterization and storage 12-1
 Winterizing 12-1
Winterizing – cleaning 12-2

This Page Intentionally Left Blank

Barletta

B O A T S

Barletta Boats | 51687 County Road 133 Bristol, IN 46507
BarlettaPontoonBoats.com | 574.825.8900